

 2022 - 2024

Lager, Betrieb & Werkstatt

Warehouse, Shop Floor & Workshop





Allit AG Kunststofftechnik

Rotlay-Mühle ■ 55545 Bad Kreuznach ■ Germany

www.allit.de ■ www.allit-group.com

- **Kunststofftechnik** ■ Plastics
- **Logistiksysteme** ■ Logistic Systems
- **Werkstatt & Lager** ■ Workshop & Warehouse
- **Dr. Heinrich Schneider Messtechnik** ■ Dr. Heinrich Schneider Metrology
- **Allit Technologie** ■ Allit Technology



Frankfurt
Bad Kreuznach



①

②



Kompetenz in Kunststoff – Können und Wissen für raffinierte Technik!

Das Familienunternehmen Allit AG Kunststofftechnik, 1960 gegründet, zählt zu den kompetentesten Herstellern von Kunststoffprodukten in Deutschland. Aus unserem Leitsatz heraus „Können und Wissen für raffinierte Technik“ entstehen eine Vielzahl innovativer und weltweit begehrter Kunststoffzeugnisse. Doch damit nicht genug. Über den Kunststoff hinaus nutzen wir auch Metalle – vor allem Aluminium – und Textilien zu weiteren, ergänzenden Artikeln für zahlreiche Anwendungsbereiche im Transport, Lager und Betrieb. Durch ausgezeichnete Produkt- und Servicequalität aus unseren Geschäftsfeldern wollen wir unsere Kunden dauerhaft begeistern und langfristige Partnerschaften aufbauen.

Geschäftsfeld „Kunststofftechnik“:

Allit ist seit mehr als 60 Jahren eine verlängerte Werkbank für namhafte Partner aus unterschiedlichsten Branchen (u.a. Filtertechnik, Getränkeindustrie, Luftfahrt, Werkzeugindustrie etc.) mit Entwicklung, Konstruktion, Werkzeugbau, Herstellung, Konfektionierung sowie Logistik. Dabei trägt Allit kontinuierlich zur technischen und wirtschaftlichen Weiterentwicklung der Produktsysteme ihrer Kunden bei.

Geschäftsfeld „Logistiksysteme“:

Allit ist der Ausrüstungshersteller mit Mehrweg-Systembehältern für Transport, Logistik, Industrie (u.a. Pharma, Textil, LEH Non Food etc.) sowie intelligenten, verkaufsfördernden

Verpackungen mit Zweitnutzen. Dabei schätzen die Kunden von Allit insbesondere die langjährige Erfahrung zur Optimierung moderner Materialflusssysteme.

Geschäftsfeld „Werkstatt & Lager“:

Allit ist Partner des Einzel-, Fach- und Versandhandels für private sowie gewerbliche Anwender. Das umfangreiche, direkt verfügbare Sortiment für Werkstatt- und Lagerausrüstung unterliegt der stetigen Weiterentwicklung. Es bietet kompetente Vermarktungs- und Logistikangebote für den stationären als auch webbasierten Handel.

Zukunft im Bewusstsein

Allit übernimmt unternehmerische Verantwortung. Das bedeutet, dass nicht nur der wirtschaftliche Erfolg der Geschäftstätigkeit im Blick steht, sondern auch deren Auswirkung auf Mitarbeiter, Gesellschaft und Umwelt. Dabei wird großen Wert auf einen verantwortungsbewussten Umgang mit allen Ressourcen gelegt.



- ① **Rohstoff-Lager** ■ Raw materials warehouse
- ② **Produktion/Montage** ■ Production/Assembly
- ③ **Produktion/Verwaltung** ■ Production/Administration
- ④ Allit Technologie GmbH
- ⑤ Dr. Heinrich Schneider Messtechnik GmbH
- ⑥ **Lager** ■ Warehouse
- ⑦ **Kommissionierung/Lager** ■ Order picking/Warehouse
- ⑧ **Lager** ■ Warehouse



Expertise in Plastic – Knowledge & Know-How for Sophisticated Technology!

Family-run enterprise Allit AG Kunststofftechnik, founded in 1960, is one of the most experienced and knowledgeable manufacturers of plastic products in Germany. Based on our guiding principle “Knowledge & Know-How for sophisticated Technology”, we create a myriad of innovative and worldwide sought-after products made of high-quality plastic material – and more: to complement our varied range, we also use metals (notably aluminium) and fabrics in the creation of smart products designed for “a thousand and one” practical uses in transport and shipping, warehousing and on the shop floor. With a constant focus on the needs of professionals operating in these areas, we maintain long-term partnerships with our clients, who appreciate the excellent product and service quality delivered by our three business segments.

Business segment “Plastics”:

For more than 60 years, Allit has been established as an “extended workbench” of renowned partners from the most diverse industries (including the filter, beverage, aviation and tooling industries). Allit takes care of product development, design, tool/mould-making, manufacture, assembly/finishing and logistics, thus helping its partners and their product systems to continuously grow and improve in terms of technical and economic performance.

Business segment “Logistics Systems”:

Allit has also made a name for itself as an equipment manufacturer focusing on system containers for transport and logistics facilities

as well as for many different industries (including the pharma, textile, food retailing, non-food business etc.). Allit also offers sales-promoting packaging solutions with smart added value. Customers particularly appreciate Allit’s wealth of experience in optimising state-of-the-art material flow systems.

Business segment “Workshop & Warehouse”:

Allit is a sought-after partner to the retail trade, the specialised trade and the mail-order business, catering to both private and industrial customers. Allit’s comprehensive, ready-to-use range of equipment products for shop floor and warehouse facilities is continuously optimised. It features smart marketing and logistics solutions that are designed not only for the stationary trade, but also for virtual sales channels.

Headed for the Future

Allit takes on corporate social responsibility. This implies a look above and beyond the economic success of business operations by considering the impact upon staff, upon society and upon the environment. Allit attaches great importance to treating all resources with the same respect and consideration.

Seit über 180 Jahren Erfahrung

Qualität, Service und Innovation

Seit über 180 Jahren begleitet unser Familienunternehmen diesen Anspruch bei der Entwicklung jährlich neuer Produkte und den Serviceleistungen. Hunderttausendfach verkaufte Produkte jährlich verpflichten uns, hohe Anforderungen an das Design und die Funktion zu stellen.

Im Jahr 1960 begann unsere Geschichte mit allit® und dem Werkstoff Kunststoff, nachdem wir schon seit 1840 in der Lederherstellung und -verarbeitung tätig waren. Seither wachsen wir kontinuierlich, nachhaltig und solide. Wir sind heute im westlichen Europa für Werkstattaufbewahrung und Lagereinrichtung zum Teil marktführend. Darüber hinaus haben wir einen sehr guten Namen im Bereich der Kunststofftechnik und Verarbeitung für Artikel der Filtrations-, Verschluss-, Werkzeugtechnik für viele namhafte Marken sowie für Logistiksysteme in der Intralogistik.

Die Basis für den Erfolg unserer Artikel sind innovative Weiterentwicklungen, die

in enger Zusammenarbeit mit Kunden entstehen. Dabei zählen die entsprechenden Media- und Logistik-Leistungen zum Kern unserer Serviceleistungen. Unsere Fähigkeit, flexibel auf viele unterschiedliche Kundenwünsche und -anforderungen einzugehen, unsere Marke manchmal eben auch hinter die Kundenmarke zu stellen, werden international geschätzt.



In folgenden Ländern sind wir durch eigenes Personal, Vertretungen oder starke Partner repräsentiert: Belgien, Frankreich, Schweiz, Italien, Großbritannien, Rumänien, Polen, Dänemark, Österreich, Luxemburg, Niederlande

We are represented by our own staff, agencies or strong partners in the following countries: Belgium, France, Switzerland, Italy, Great Britain, Romania, Poland, Denmark, Austria, Luxembourg, Netherlands

More than 180 years of experience

Quality, service and innovation

For more than 180 years, our family business has accompanied this claim in the development of new products and services. Hundreds of thousands of products sold every year oblige us to place high demands on design and function.

Our history of allit® with the material plastic began in 1960, after we had been active in leather production and processing since 1840. Since then we have been growing continuously, sustainably and solidly. Today we are partly the market leader in western Europe for workshop storage and warehouse equipment. In addition, we have a very good name in the field of plastics processing for articles in filtration, closure and tool technology for many well-known brands as well as for logistics systems.

The basis for the success of our articles are innovative further developments that arise in close cooperation with customers. The corresponding media and logistics services are part of the core of our services. Our ability to respond flexibly to many different customer wishes and requirements, and sometimes to put our brand behind the customer's brand, is valued internationally.

Hochwertige, innovative Qualitätsprodukte

Made und/oder Engineered in Germany

„Made und/oder Engineered in Germany“ steht bei allit® nicht nur für hervorragende Qualität und Innovation, sondern auch für den Ursprung des Familienunternehmens. Dieser ist der stetig wachsende Standort in Bad Kreuznach – hier werden Produkte und Produktinnovationen entwickelt, hergestellt und unter hohen Standards im eigenen Qualitätsmanagement geprüft. Gegründet als Familienunternehmen ist allit® eine international agierende und bekannte Marke. In über 30 Ländern sind die Produkte bekannt. „Made in Germany“ oder „Engineered in Germany“ unterstreichen deshalb unseren Anspruch an sorgfältige Verarbeitung und qualitativ hochwertige Produkte mit hohem Nutzen.



Made in Germany

Engineered in Germany

High quality, innovative quality products

Made and/or Engineered in Germany

At allit®, „Made and/or Engineered in Germany“ not only stands for excellent quality and innovation, but also for the origin of the family business. This is the steadily growing location in Bad Kreuznach – here products and product innovations are developed, manufactured and tested under high standards in our own quality management. Founded as a family business, allit® is an internationally active and well-known brand. The products are known in over 30 countries. „Made in Germany“ or „Engineered in Germany“ therefore underline our claim to careful processing and high-quality products with great benefits.



For more information
please scan QR-Code

Nachhaltigkeit und Qualität

Allit hält Qualitäts- und Umweltstandards ein, die ebenfalls durch unabhängige Institute geprüft werden:

- Eigenes Qualitäts-Messlabor durch die Tochtergesellschaft Dr. Heinrich Schneider Messtechnik GmbH
- Optische und taktile Messtechnik
- Material- und Farbgiüten-Prüfungen
- Kundenspezifische Prüfverfahren
- Firmeneigene Photovoltaikanlage
- Geschlossene Kühlkreisläufe in der Fertigung
- Ressourcenschonende Artikel-Konstruktion
- Reduktion der innerbetrieblichen Verpackungen durch z. B. eigene Mehrwegsystem-Behälter

Sustainability and Quality

Allit has quality and environmental standards in place that are verified both in-house and by independent institutes:

- In-house quality measurement laboratory provided by Allit's subsidiary Dr. Heinrich Schneider Messtechnik GmbH
- Optical and tactile measurement technology
- Material and colour quality testing
- Customer-specific testing procedures
- Company-owned photovoltaic system
- Closed-loop cooling circuits in products
- Efficient use of raw materials in article manufacture
- Reduction of in-house packaging materials by employing (for example) the reusable - system containers made by Allit

Chancen und Vorteile als Allit-Handelspartner

Als Partner des Fachhandels wollen wir, dass Sie erfolgreich sind. Für uns ist es daher selbstverständlich, dass wir kein Direktgeschäft betreiben, sondern Sie als unseren Partner unterstützen. Profitieren Sie von unserer Fachhändler-Unterstützung.

Bereits seit Jahrzehnten sind wir im Versandhandelsgeschäft präsent und bauen unsere Kompetenz stetig weiter aus. Mit einer Lieferquote von über 98 % sind wir der ideale Partner. Wir geben Ihnen die Umsatzsicherheit für Ihren gewerblichen Endkunden. Unsere Unterstützung hört mit unseren attraktiven, qualitativ hochwertigen Produkten noch nicht auf.

Gerne unterstützen wir Sie bei der Erstellung von umsatzstarken Seitenvorschlägen in Ihrem Layout oder Florpost. Wir verfügen über ein sehr umfangreiches Archiv von Bildern und Produktbeschreibungen, auf welches Sie als unser Partner zugreifen dürfen.

Your opportunities and benefits as a trading partner of Allit

We are a fair and reliable partner to the specialised trade – therefore, we will always be committed to ensuring YOUR success as a dealer. This means that we will not engage in direct trading, but will rather support you as our valued partner.

We will be pleased to assist you in creating sales-boosting design proposals for your layout. We host an extensive archive of photos, illustrations and product descriptions to which you as our partner will always have access.



Verbraucherfreundliche Artikelpräsentation

- Selbsterklärende Warenpräsentation
- Anlieferung als abverkaufsstarke Produktpräsentation zur Zweitplatzierung
- Ansprechende Optik im Verkaufsregal

Consumer-friendly product display

- Self-explaining presentation
- Delivery in a sales-boosting shop display for perfect secondary placement
- Optimum visual appeal on the sale shelf



Allit Produktfinder www.allit24.com

Artikelbeschreibungen, Fotos, Videos und weitere Informationen zum Allit Sortiment finden Sie im Produktfinder. Jedes Produkt ist über einen QR-Code mit seinem jeweiligen Artikel online verbunden.

Wir möchten zum einen unsere professionellen Kunden mit den nötigen Informationen versorgen, die im Alltag der Arbeit mit Allit-Produkten unerlässlich sind. Zugleich wollen wir Heimwerkern und Kreativen den umfangreichen Überblick bieten, den sie benötigen.

Allit productfinder www.allit24.com

Item descriptions, photos, videos and further information on the Allit range can be found in the productfinder. Each product is connected to its respective article online via QR code.

The two-part classification enables us to provide our professional customers with all the information they need in their everyday use of Allit products, whether at work or in other settings. And at the same time, we can also offer DIY enthusiasts and creative hobbyists the comprehensive overview they need to make the right choices for their projects.

Weitere Kataloge / Further Catalogues

Der vorliegende Katalog „Lager, Betrieb & Werkstatt“ beinhaltet nur ein Teil unseres Gesamtassortiments. Bitte kontaktieren Sie uns, wenn Sie weitere Kataloge/Prospekte erhalten möchten, oder besuchen unsere Website www.allit.de.

The present catalog „Warehouse, Shop Floor & Workshop“ contains only a part of our complete assortment. Please contact us if you would like to receive further catalogs / brochures or visit our website www.allit.de.

Heimwerker / DIY enthusiasts



Handwerker / Industrie Craftsmen / Industry



Behälter / Totes



**Behälter für professionelle Kommissionierung,
Transport & Lagerung /
Totes for professional Picking, Transport & Storage**

Highlights



**Wechselnde Angebote aus dem
Fachhandelsprogramm Lager und Betrieb /
Changing offers from the specialized
trade program warehouse and shop floor**

Seite / Page 2 - 7

**Unternehmen
Company**

Kompetenz in Kunststoff – Können und Wissen für raffinierte Technik
Expertise in Plastic – Knowledge & Know-How for Sophisticated Technology!

Seite / Page 10 - 27

**Servicekoffer
Service Cases**



Seite / Page 28 - 53

**Werkzeug- &
Aufbewahrungskoffer
Tool & Storage
Cases**

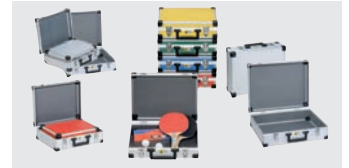

Seite / Page 54 - 91

**Kleinteilekoffer &
Sortimentskästen
Small parts cases &
Assortment boxes**



Seite / Page 92 - 107

**Kleinteilemagazine
Small parts
cabinets**



Seite / Page 108 - 133

**Stapel- &
Regalboxen
Stackable storage
bins & shelf bins**



Seite / Page 134 - 159

**Transport- &
Lagerboxen
Transport &
storage boxes**



Seite / Page 160 - 163

**Weitere Infos
Further
information**

Produktindex, Erklärung Piktogramme und Farben, Notizen
Product index, Explanation of pictograms and colors, Notes



Kennzeichnung der Produkte nach: / Labeling of the products according to:

- 1 Blau = Pro-Artikel
- 2 Blue = Pro-items

- 1 Rot = DIY-Artikel
- 2 Red = DIY-items

Innovative Service- und Montagekoffer aus Polycarbonat, ABS- oder als Alu-Rahmen-Koffer. Das Sortiment zeigt eine Bandbreite und bietet eine große Vielfalt zur Organisation und Aufbewahrung im Betrieb, auf Montage oder im Serviceeinsatz.

Innovative field service & technicians cases made of polycarbonate, ABS or as aluminum frame case. The range of useful storage aids provides innumerable options for smart organisation and storage, not only on the shop floor and in the workshop, but also in transit and in the field.

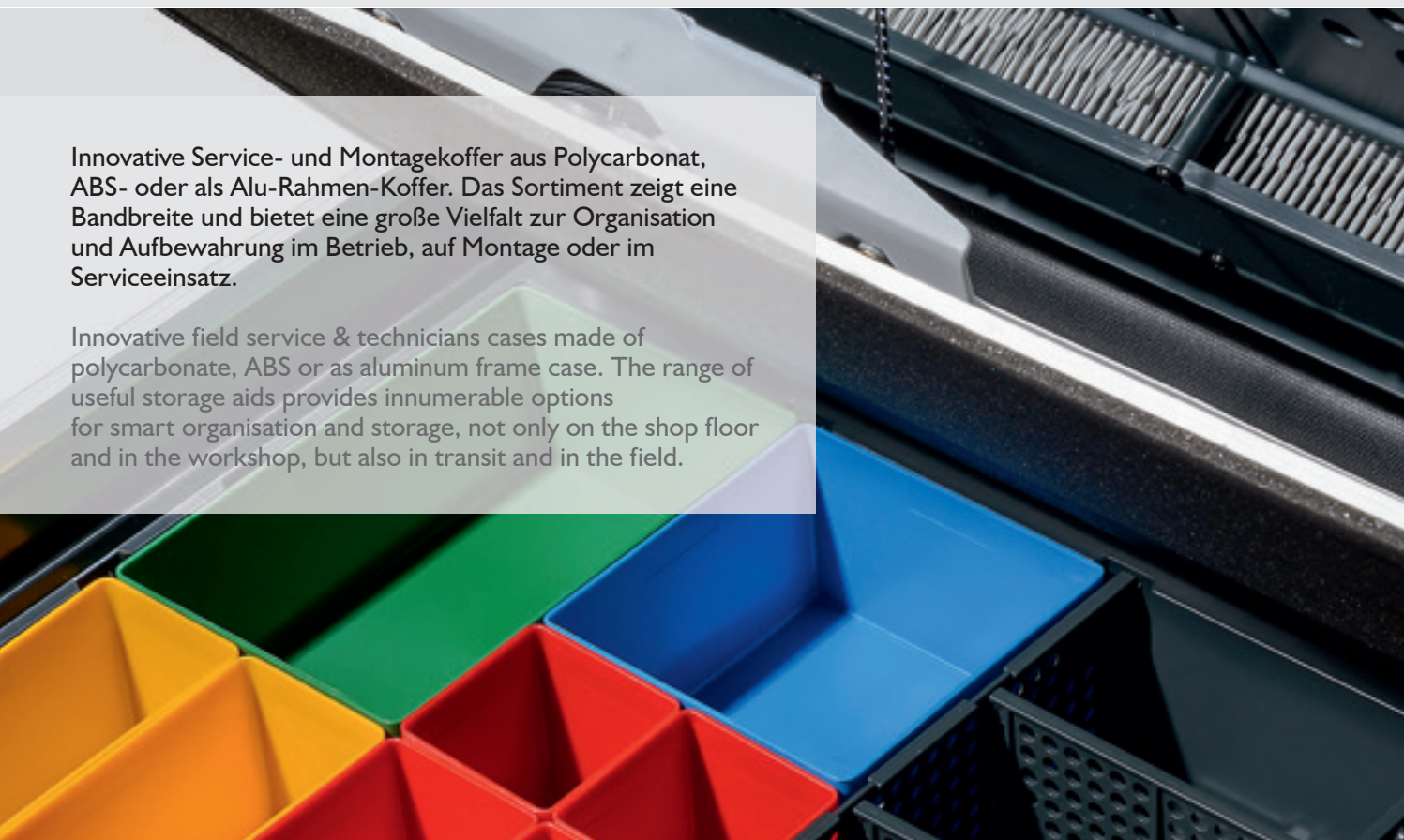

ProServe

12



ProServe R270

14



ProServe 200

16



ProServe R170

18



ProServe 170

20



ProServe Zubehör / Accessoires

22

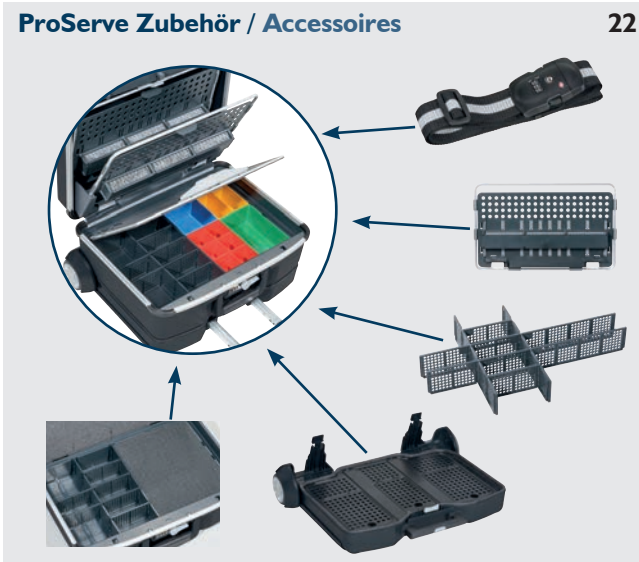

AluPlus Service ›ABS‹

24



AluPlus Service ›C‹ 50

25



AluPlus Service ›C‹ 44

26

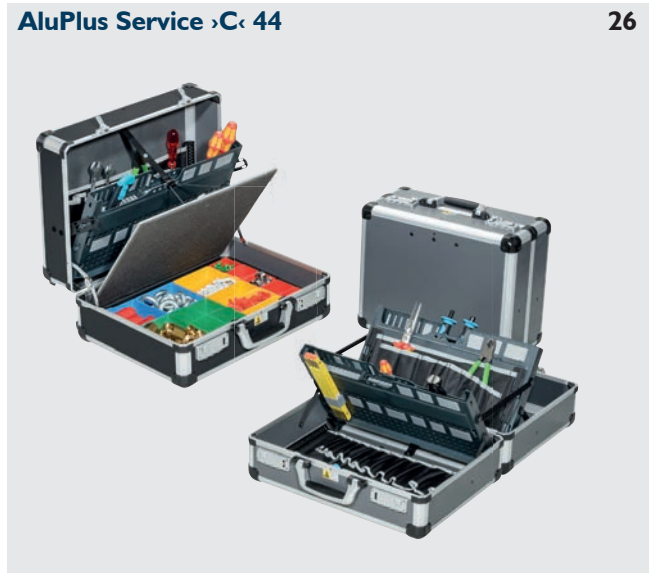

Der innovative Service- und Montagekoffer

Der ProServe ist ein innovativer sowie robuster Service- und Montagekoffer in einem attraktiven Kofferdesign und einem Aluminium-Rahmen mit stabilen Stoßecken. Der Koffer wird aus Polycarbonat, einem der härtesten Kunststoffe, im besonderen Spritzgussverfahren hergestellt. Er bietet damit eine außerordentliche Schlagzähigkeit in einem breiten Temperaturbereich. Bis zu 35 kg Zuladung sind durch die Verwendung der hoch belastbaren und stabilen Komponenten möglich. Des Weiteren ist eine Trolley-Fahreinheit separat erhältlich.

The innovative field service & technicians case

ProServe is an innovative and robust field service and technicians case with a handsome design featuring an aluminium frame and rugged corner guards. The cases are manufactured from polycarbonate, which is one of the toughest plastic materials, in a special injection moulding process. The cases provide outstanding impact resistance over a wide temperature range. Thanks to its high load capacity and sturdy components, it will readily accept loads of up to 35 kg! of extra load! A wheeled trolley unit is available separately.

Materialeigenschaften:

Polycarbonate zeichnen sich durch hohe Festigkeit, Schlagzähigkeit, Steifigkeit und Härte aus. Außerdem sind Polycarbonate gute Isolatoren gegen elektrischen Strom. Polycarbonate sind beständig gegenüber Wasser, vielen Mineralsäuren und wässrigen Lösungen von neutralen Salzen und Oxidationsmitteln. Auch einige unpolare organische Lösungsmittel, wie Kohlenwasserstoffe und viele Öle und Fette, greifen Polycarbonate nicht an. Durch eine besonders sensible Spritzgussverarbeitung wird eine geringe Eigenspannung im Material und somit hohe Alterungsbeständigkeit erreicht.

Properties of polycarbonate:

Polycarbonates are characterised by high dimensional stability, good impact resistance as well as great rigidity and hardness. In addition, they are excellent insulators against electric current. Polycarbonates are resistant not only to water and many mineral acids, but also to aqueous solutions of neutral salts and oxidants. Polycarbonates also withstand various non-polar organic solvents such as hydrocarbons as well as many oils and greases. Application of a particularly sensitive injection moulding process ensures low internal stress in the cases and thus high resistance to ageing.

Weitere Einsatzgebiete für Polycarbonat:

Polycarbonate is used in many different industries and areas:



Dach Olympiastadion in München
Roof of the Olympic Stadium in Munich



Reisekoffer / Suitcase

Dichter Verschluss durch Aluminium-Profilrahmen
Tight fit and closure thanks to the aluminium profile frame



Leichtlaufende, kugelgelagerte, hochverschleißfeste Räder

Smooth-running, highly wear-resistant castors mounted on ball bearings

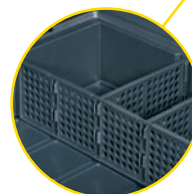

Trennsteg sitzen sicher in Schwalbenschwanzführungen

Dividers sit firmly in place thanks to dovetailed guides

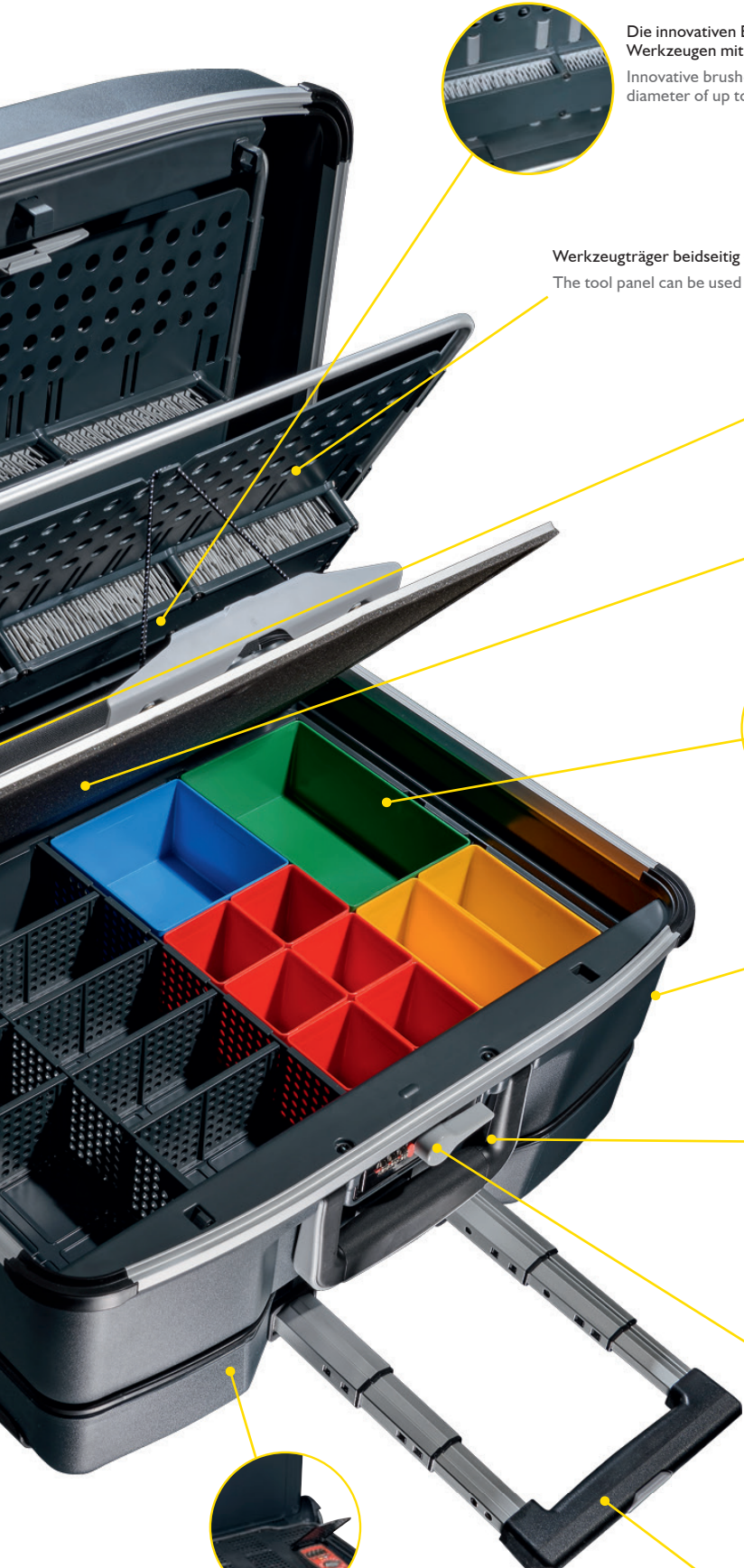

Die innovativen Bürstenhalter ermöglichen den flexiblen und beliebigen Einsatz von Werkzeugen mit einem Durchmesser bis zu 15 mm

Innovative brush-type holders enable flexible and versatile insertion of tools with a diameter of up to 15 mm

Werkzeugträger beidseitig einsetzbar
The tool panel can be used on both sides



Innovative Deckelbremse mit Einrast- und Bremsfunktion

Innovative "lid brake" with locking and braking function



Verschließbarer Deckel mit Schaumstoffunterseite sichert den Inhalt im geschlossenen Zustand ab und bietet eine Anbringung für Textil-Werkzeughalter und -taschen

The fold-down lid with foam-lined underside protects the items inside while the tool case is closed and offers plenty of space for accommodating textile tool panels and pockets



EuroPlus Inserts in Industriestandardgrößen sind mit vielen Systemen kompatibel

EuroPlus Insert bins in industry standard sizes are compatible with many systems

Einfaches Schließen durch Zudrücken des Koffers
The case is easily closable by pressing the halves together



Einfaches Öffnen durch einen Einhandhebel
Easy opening thanks to the single-hand lever

Zahlschloss für sicheren Inhalt; für einen sicheren Verschluss während eines Fluges empfiehlt sich ein Koffergurt mit TSA-gesichertem Zahlschloss

A combination lock is available for securing the items inside; for even safer closure and security locking during air transport, use of a luggage strap equipped with a TSA combination lock is recommended



Abnehmbare Trolley-Fahreinheit mit zusätzlichen Fächern
Detachable wheeled trolley unit with extra storage compartments

4-fach Aluminium-Teleskopauszug
4-step telescopic aluminium handle

Mobiler Service- und Montagekoffer

Willkommen in der absoluten Oberklasse - der fahrbare Service- und Montagekoffer ProServe R270. Sein Einhand-Zentralverschluss ermöglicht einen einfachen Zugriff und gleichzeitig ein schnelles, sicheres Verschließen. Mit ergonomischem Zwei-Komponenten-Griff. Die Koffer besitzen ein tiefes Unterteil, das mit einer Trolley-Fahreinheit ausgestattet ist und zusätzliche Stauraumfächer bietet. Sie verschließt abdichtend an der Kofferunterseite mittels solidem Schnappverschluss.

Mobile field service & technicians cases

Welcome to the very premium league of field service & technicians cases featuring quality on wheels: Allit's R270 range! Their central closure designed for one-hand operation provides easy access to the items inside whilst ensuring fast and safe closure. The cases come equipped with an ergonomic two-component handle, and they feature a deep lower shell equipped with a wheeled trolley unit offering extra storage compartments. Thanks to a sturdy snap lock, it forms a tight fit with the case's lower shell.



Alle Koffer mit Zahlenschlössern
All cases are equipped with combination locks



Einrastfelder verhindern das Verrutschen der Einsatzboxen
Dedicated snap-in areas keep insert bins perfectly in place

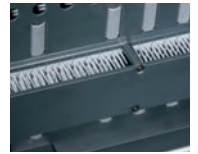

Flexibel nutzbare Bürstentypenhalter bis Ø 15 mm
Flexibly usable brush-type holders for tools of up to Ø 15 mm



Arretierbare Kunststoff-Trennsteg in Schwalbenschwanzführung
Plastic dividers can be secured in place by means of dovetail guides



Innovative Deckelbremse mit Einrast- und Bremsfunktion
Innovative "lid brake" with snap-in function



Vorteilhafte Verschluss-Abdeckplatte
Useful fold-down cover panel



GERMAN DESIGN AWARD WINNER 2018



	EAN	Color	Dimensions (mm)	Volume (mm)	Truck	Box
1 ProServe R270-100	457800(3)	Black	540 x 405 x 270	435 x 275 x 185	1	5
2 ProServe R270-200	457810(2)	Black	540 x 405 x 270	435 x 275 x 185	1	5
3 ProServe R270-300	457820(1)	Black	540 x 405 x 270	435 x 275 x 185	1	5
4 ProServe R270-400	457830(0)	Black	540 x 405 x 270	435 x 275 x 185	1	5

EAN = 4005187 + Art. Nr. ohne führende „4“ + Prüfziffer (X) / EAN = 4005187 + Art. No. without leading "4" + check digit (X)



Polycarbonat/ABS, Aluminium, Holz, Kunststoff, Textilien, Schaumstoff / Polycarbonate/ABS, aluminium, wood, plastics, textile material, foam



1

ProServe R270-100

- enthält Aufnahmen für separat erhältliche Trennstege, Einsatzboxen und Werkzeugträger
- eine Trolley-Fahreinheit mit 4-fach Teleskopauszug und drei Staufächern
- Equipped with grooves for separately available dividers, insert bins and tool panels
- One wheeled trolley unit with 4-step telescopic handle and three storage compartments



2

ProServe R270-200

- zwei Querteiler, zwei lange Trennstege, sechs kurze Trennstege
- zwei Werkzeugträger mit Bürstenhalter, Gummischlaufen und Textilschlaufen
- eine Trolley-Fahreinheit mit 4-fach Teleskopauszug und drei Staufächern
- Two crosswise dividers, two long dividers, six short dividers
- Two tool panels with brush-type holder, elastic loops and textile loops
- One wheeled trolley unit with 4-step telescopic handle and three storage compartments

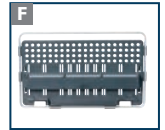

3

ProServe R270-300

- zwei Querteiler, sechs kurze Trennstege
- 10 Einsatzboxen
- zwei Werkzeugträger mit Bürstenhalter, Textilschlaufen und Textiltaschen
- eine Trolley-Fahreinheit mit 4-fach Teleskopauszug und drei Staufächern
- Two crosswise dividers, six short dividers
- 10 insert bins
- Two tool panels with brush-type holder, textile loops and textile pockets
- One wheeled trolley unit with 4-step telescopic handle and three storage compartments

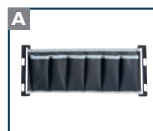
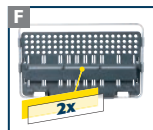

4

ProServe R270-400

- ein Querteiler
- 20 Einsatzboxen
- zwei Werkzeugträger mit Bürstenhalter und Textiltaschen
- eine Trolley-Fahreinheit mit 4-fach Teleskopauszug und drei Staufächern
- One crosswise divider
- 20 insert bins
- Two tool panel with brush-type holder, elastic loops and textile pockets
- One wheeled trolley unit with 4-step telescopic handle and three storage compartments

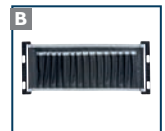
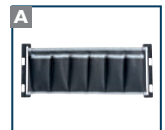
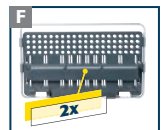

Service- und Montagekoffer

Besticht in seinem robusten und attraktiven Design. Sein Einhand-Zentralverschluss ermöglicht einen einfachen Zugriff und gleichzeitig ein schnelles, sicheres Verschließen. Mit ergonomischen Zwei-Komponenten Griff. Der ProServe 200 verfügt über ein tieferes Unterteil als der ProServe 170 und bietet somit noch mehr Platz für Werkzeuge, Kleinteile, Messgeräte, etc. Im Gegensatz zum ProServe 170 kann der ProServe 200 mit einer Trolley-Fahreinheit ausgestattet werden.

Field service & technicians cases

These cases impress with their robust and attractive design. Their central closure designed for one-hand operation ensures easy access to the items inside as well as fast and safe closure. The cases come equipped with an ergonomic two-component handle. Since the lower shell of ProServe 200 is deeper than that of ProServe 170, it provides even more storage space for tools, small parts, measuring devices etc. In contrast to ProServe 170, field service & technicians case ProServe 200 can be equipped with a wheeled trolley unit.



Alle Koffer mit Zahlenschlössern
All cases are equipped with combination locks



Einrastfelder verhindern das Verrutschen der Einsatzboxen
Dedicated snap-in areas keep insert bins perfectly in place



Flexibel nutzbare Bürstentypenhalter bis Ø 15 mm
Flexibly usable brush-type holders for tools of up to Ø 15 mm



Arretrierbare Kunststoff-Trennstege in Schwalbenschwanzführung
Plastic dividers can be secured in place by means of dovetail guides



Innovative Deckelbremse mit Einrast- und Bremsfunktion
Innovative "lid brake" with snap-in function



Vorteilhafte Verschluss-Abdeckplatte
Useful fold-down cover panel



	EAN	Color	Dimensions (mm)	Internal Dimensions (mm)	Weight (kg)	Volume (L)
1 ProServe 200-100	457700(6)	Black/Gray	490 x 405 x 200	435 x 275 x 185	1	21
2 ProServe 200-200	457710(5)	Black/Gray	490 x 405 x 200	435 x 275 x 185	1	5
3 ProServe 200-300	457720(4)	Black/Gray	490 x 405 x 200	435 x 275 x 185	1	5
4 ProServe 200-400	457730(3)	Black/Gray	490 x 405 x 200	435 x 275 x 185	1	5

EAN = 4005187 + Art. Nr. ohne führende „4“ + Prüzfiffer (X) / EAN = 4005187 + Art. No. without leading “4” + check digit (X)



1

ProServe 200-100

- enthält Aufnahmen für separat erhältliche Trennstege, Einsatzboxen und Werkzeugträger
- Equipped with grooves for separately available dividers, insert bins and tool panels



2

ProServe 200-200

- zwei Querteiler, zwei lange Trennstege, sechs kurze Trennstege
- zwei Werkzeugträger mit Bürstenhalter, Gummischlaufen und Textilschlaufen
- Two crosswise dividers, two long dividers, six short dividers
- Two tool panels with brush-type holder, elastic loops and textile loops

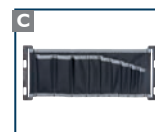
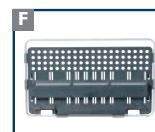
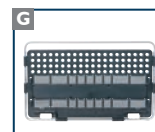
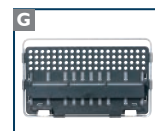

3

ProServe 200-300

- zwei Querteiler, sechs kurze Trennstege
- 10 Einsatzboxen
- zwei Werkzeugträger mit Bürstenhalter, Textilschlaufen und Textiltaschen.
- Two crosswise dividers, six short dividers
- 10 insert bins
- Two tool panels with brush-type holder, textile loops and textile pockets

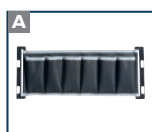
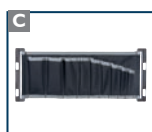
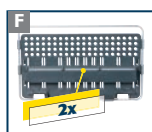

4

ProServe 200-400

- ein Querteiler
- 20 Einsatzboxen
- zwei Werkzeugträger mit Bürstenhalter und Textiltaschen
- One crosswise divider
- 20 insert bins
- Two tool panel with brush-type holder, elastic loops and textile pockets

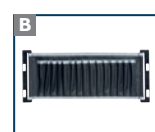
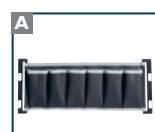
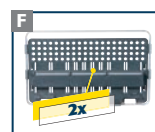

Mobiler Service- und Montagekoffer

Glänzt durch sein schlankes und attraktives Design sowie durch den fest integrierten Trolley. Seine Einhand-Verschlussklappe ermöglicht einen einfachen Zugriff und gleichzeitig ein schnelles, sicheres Verschließen. Mit ergonomischen Zwei-Komponenten Griff.

Mobile field service & technicians cases

These cases impress with their slim and attractive design as well as with the integrated trolley unit. Their central closing flap conceived for one-hand use provides ready access to the items inside whilst also ensuring quick and reliable closure. The cases come equipped with an ergonomic two-component handle.



Alle Koffer mit Zahlenschlössern
All cases are equipped with combination locks



Einrastfelder verhindern das Verrutschen der Einsatzboxen
Dedicated snap-in areas keep insert bins perfectly in place

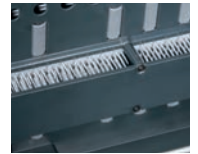

Flexibel nutzbare Bürstentypenhalter bis Ø 15 mm
Flexibly usable brush-type holders for tools of up to Ø 15 mm



Arretierbare Kunststoff-Trennsteg in Schwalbenschwanzführung
Plastic dividers can be secured in place by means of dovetail guides



Innovative Deckelbremse mit Einrast und Bremsfunktion
Innovative "lid brake" with snap-in function



Vorteilhafte Verschluss-Abdeckplatte
Useful fold-down cover panel

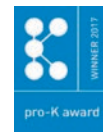

mm



mm



	EAN	Color	Dimensions (mm)	Dimensions (mm)	Weight (kg)	Volume (L)
1	ProServe R170-100	457605(4)	490 x 425 x 200	435 x 275 x 150	1	21
2	ProServe R170-200	457615(3)	490 x 425 x 200	435 x 275 x 150	1	5
3	ProServe R170-300	457625(2)	490 x 425 x 200	435 x 275 x 150	1	21
4	ProServe R170-400	457635(1)	490 x 425 x 200	435 x 275 x 150	1	21
5	ProServe R170-500	457645(0)	490 x 425 x 200	435 x 275 x 150	1	21

EAN = 4005187 + Art. Nr. ohne führende „4“ + Prüfziffer (X) / EAN = 4005187 + Art. No. without leading "4" + check digit (X)



Polycarbonat/ABS, Aluminium, Holz, Kunststoff, Textilien, Schaumstoff / Polycarbonate/ABS, Aluminium, Wood, Plastics, Textile material, Foam



1

ProServe R170-100

- enthält Aufnahmen für separat erhältliche Trennstegge, Einsatzboxen und Werkzeugträger
- Equipped with grooves for separately available dividers, insert bins and tool panels



2

ProServe R170-200

- zwei Querteiler, zwei lange Trennstegge, sechs kurze Trennstegge
- ein Werkzeugträger mit Bürstenhalter und Gummischlaufen
- Two crosswise dividers, two long dividers, six short dividers
- One tool panel with brush-type holder and elastic loops

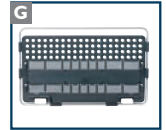

3

ProServe R170-300

- zwei Querteiler, sechs kurze Trennstegge
- 10 Einsatzboxen
- ein Werkzeugträger mit Bürstenhalter und Textilschlaufen
- Two crosswise dividers, six short dividers
- 10 insert bins
- One tool panel with brush-type holder and textile loops

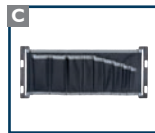
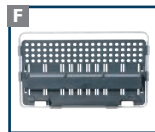

4

ProServe R170-400

- ein Querteiler
- 20 Einsatzboxen
- ein Werkzeugträger mit Bürstenhalter und Textiltaschen
- One crosswise divider
- 20 insert bins
- One tool panel with brush-type holder and textile pockets

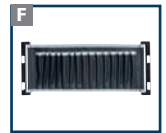
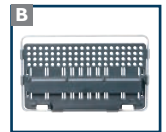

5

ProServe R170-500

- zwei Querteiler, sechs kurze Trennstegge
- Schaumstoff
- ein Werkzeugträger mit Bürstenhalter, Gummischlaufen und Textiltaschen
- Two crosswise dividers, six short dividers
- Foam
- One tool panel with brush-type holder, elastic loops and textile pockets



Service- und Montagekoffer

Besticht in seinem schlanken und attraktiven Design. Seine Einhand-Verschlussklappe ermöglicht einen einfachen Zugriff und gleichzeitig ein schnelles, sicheres Verschließen.

Field service & technicians cases

These cases impress with their slim and attractive design. Their central closing flap conceived for one-hand use provides ready access to the items inside whilst also ensuring quick and reliable closure.



Alle Koffer mit Zahlenschlössern
All cases are equipped with combination locks



Einrastfelder verhindern das Verrutschen der Einsatzboxen
Dedicated snap-in areas keep insert bins perfectly in place

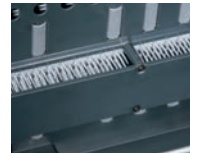

Flexibel nutzbare Bürstenhalter bis Ø 15 mm
Flexibly usable brush-type holders for tools of up to Ø 15 mm



Arretrierbare Kunststoff-Trennsteg in Schwalbenschwanzführung
Plastic dividers can be secured in place by means of dovetail guides



Innovative Deckelbremse mit Einrastund Bremsfunktion
Innovative "lid brake" with snap-in function



Vorteilhafte Verschluss-Abdeckplatte
Useful fold-down cover panel



mm



mm



	EAN	Icon	Dimensions (mm)	Dimensions (mm)	Boxes	Trucks
1 ProServe 170-100	457600(9)	Black	490 x 425 x 170	435 x 275 x 150	1	21
2 ProServe 170-200	457610(8)	Black	490 x 425 x 170	435 x 275 x 150	1	21
3 ProServe 170-300	457620(7)	Black	490 x 425 x 170	435 x 275 x 150	1	21
4 ProServe 170-400	457630(6)	Black	490 x 425 x 170	435 x 275 x 150	1	21
5 ProServe 170-500	457640(5)	Black	490 x 425 x 170	435 x 275 x 150	1	21

EAN = 4005187 + Art. Nr. ohne führende „4“ + Prüfziffer (X) / EAN = 4005187 + Art. No. without leading "4" + check digit (X)



Polycarbonat/ABS, Aluminium, Holz, Kunststoff, Textilien, Schaumstoff / Polycarbonate/ABS, Aluminium, Wood, Plastics, Textile material, Foam



1

ProServe 170-100

- enthält Aufnahmen für separat erhältliche Trennstege, Einsatzboxen und Werkzeugträger
- Equipped with grooves for separately available dividers, insert bins and tool panels



2

ProServe 170-200

- zwei Querteiler, zwei lange Trennstege, sechs kurze Trennstege
- ein Werkzeugträger mit Bürstenhalter und Gummischlaufen
- Two crosswise dividers, two long dividers, six short dividers
- One tool panel with brush-type holder and elastic loops



3

ProServe 170-300

- zwei Querteiler, sechs kurze Trennstege
- 10 Einsatzboxen
- ein Werkzeugträger mit Bürstenhalter und Textilschlaufen
- Two crosswise dividers, six short dividers
- 10 insert bins
- One tool panel with brush-type holder and textile loops

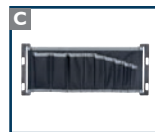
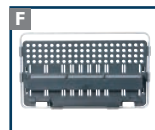

4

ProServe 170-400

- ein Querteiler
- 20 Einsatzboxen
- ein Werkzeugträger mit Bürstenhalter und Textiltaschen
- One crosswise divider
- 20 insert bins
- One tool panel with brush-type holder and textile pockets

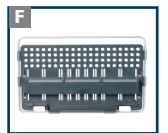

5

ProServe 170-500

- zwei Querteiler, sechs kurze Trennstege
- Schaumstoff
- ein Werkzeugträger mit Bürstenhalten, Gummischlaufen und Textiltaschen
- Two crosswise dividers, six short dividers
- Foam
- One tool panel with brush-type holder, elastic loops and textile pockets

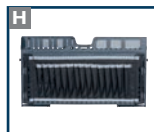

Nachrüstbares Zubehör für unsere ProServe Koffer

Retrofittable accessories for Allit ProServe field service & technicians cases



Nachstehende Tabelle zeigt die Kombinationsmöglichkeiten.

The table below provides an overview of all currently available combination options.

				System 170	ProServe 170 100-500	System R170	ProServe R170 100-500	System 200	ProServe 200 100-400	System R270	ProServe R270 100-400
A ProServe Textile .P. 6	457990(1)	1	5		■		■		■		■
B ProServe Textile .P. 15	457991(8)	1	5		■		■		■		■
C ProServe Textile .FL. 9	457992(5)	1	5		■		■		■		■
D ProServe Textile .L. 12	457993(2)	1	5		■		■		■		■
E ProServe Textile .PL. 7/6	457994(9)	1	5		■		■		■		■
F ProServe Holder .B. 3/15	457900(0)	1	5		■		■		■		■
G ProServe Holder .BL. 3/15-18	457910(9)	1	5		■		■		■		■
H ProServe Holder .PL. 21/6	457915(4)	1	5		■		■		■		■
I ProServe Insert Set 1	457920(8)	1	5		■		■		■		■
K ProServe Insert Set 2	457930(7)	1	5		■		■		■		■
L ProServe Foam 435	457935(2)	1	5		■		■		■		■
M ProServe Foam 217	457936(9)	1	5		■		■		■		■
N ProServe Divider Set 1	457940(6)	1	5		■		■		■		■
O ProServe Divider Set 2	457950(5)	1	5		■		■		■		■
P ProServe Divider Set 3	457960(4)	1	5		■		■		■		■
Q ProServe TSA Strap 220	457970(3)	1	5		■		■		■		■
R ProServe Trolleybox 270	457980(2)	1	5		■		■		■		■

EAN = 4005187 + Art. Nr. ohne führende „4“ + Prüfziffer (X) / EAN = 4005187 + Art. No. without leading “4” + check digit (X)



Polycarbonat/ABS, Aluminium, Holz, Kunststoff, Textilien, Schaumstoff / Polycarbonate/ABS, Aluminium, Wood, Plastics, Textile material, Foam



A

6 Taschen /
6 pockets

B

15 Taschen /
15 pockets

C

9 Textilschlaufen /
9 textile loops

D

12 Gummischlaufen /
12 elastic loops

E

7 Taschen +
6 Gummischlaufen /
7 pockets + 6 elastic loops

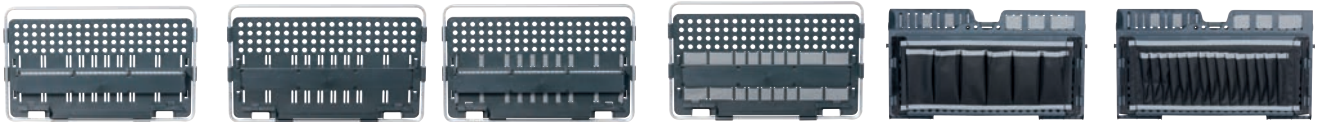

F

Holder Basic Vorne /
Holder Basic: front

F

Holder Basic Hinten /
Holder Basic: rear

G

Holder Basic Loop Vorne /
Holder Basic Loop: front

G

Holder Basic Loop Hinten /
Holder Basic Loop: rear

H

Holder mit 6 Taschen /
Panel equipped
with 6 pockets

H

Holder mit 15 Taschen /
Panel equipped with
15 pockets



I

Insert Set 1



K

Insert Set 2



EuroPlus Insert
(siehe S. 78 / see p. 78)

- (6 x) 48 x 48 x 60 mm *
- (2 x) 48 x 101 x 60 mm *
- (1 x) 101 x 101 x 60 mm *
- (1 x) 101 x 155 x 60 mm *

- (2 x) 48 x 48 x 60 mm *
- (3 x) 48 x 101 x 60 mm *
- (1 x) 101 x 101 x 60 mm *
- (1 x) 101 x 209 x 60 mm *

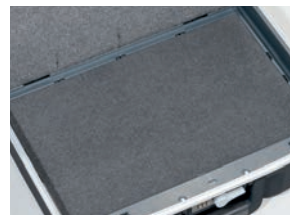

L

Foam 435

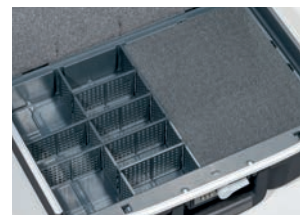

M

Foam 217

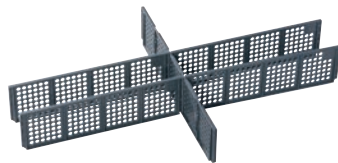

N

Divider Set 1



O

Divider Set 2

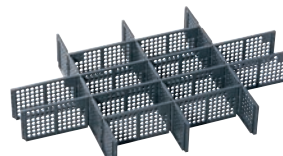

P

Divider Set 3



Q

TSA Strap

ProServe Trolleybox 270

Kann am ProServe 200 nachgerüstet werden. Sie verschließt abdichtend an der Kofferunterseite mittels solidem Schnappverschluss. Weiterhin besitzt sie einen 4-fach Aluminium-Teleskopauszug mit einer Druckknopf-Betätigung, Gleitschutzleisten sowie leichtlaufende, kugelgelagerte und hochverschleißfeste Räder mit Ø ca. 85 mm.

ProServe 200 can be retrofitted with a wheeled trolley unit. Thanks to a sturdy snap lock, it forms a tight fit with the case's lower shell. In addition, the trolley features a 4-step telescopic aluminium handle operated with a push button, an anti-skid protection mechanism as well as smooth-running, highly wear-resistant castors (Ø approx. 85 mm) mounted on ball bearings.

Drei Stauraumfächer für Kleinteile:

Three storage compartments for small parts:



- 2x 130 x 275 x 45 mm *
- 1x 95 x 275 x 45 mm *

* Nutzmaße / Usable dimensions



R

Service- und Montagekoffer mit stabiler ABS-Schale

Die robusten Hartschalenkoffer für den täglichen Einsatz im Kundendienst oder bei der Montage. Der Koffer ist mittels einem Zahlenschloss abschließbar. Der Hartschalenkoffer ist im Profi-Dauereinsatz bis 20 kg getestet. Ein Tragegurt ist im Lieferumfang jedes Koffers enthalten.

Service and assembly case with robust ABS shell

The robust hard case for daily use in the customer service or assembly. The suitcase is by means of one lockable lock. The hard-top case has been tested under PROFESSIONAL continuous-use conditions with loads of up to 20 kg. A carrying strap is included with each case.



Flexible Facheinteilung im Unterteil
Flexible compartment division in the lower part



Klappbares Werkzeugtableau mit Haltetaschen
Fold-down (fanlike) tool panels



Umlaufender Stoßkantenschutz
Circumferential corner guards



Abschließbar, inkl. Schlüssel
Key-lockable, key included



Schlagfestes ABS Material
Impact-resistant ABS materia



1



2



3



mm



mm



	EAN	Color	Dimensions (mm)	Volume (mm)	Boxes	Trucks
1	AluPlus Service >ABS< 48	422220(3)	480 x 200 x 350	415 x 170 x 275	1	5
2	AluPlus Service >ABS< 50	422225(8)	500 x 220 x 400	420 x 200 x 320	1	5
3	AluPlus Service >ABS< R50	422230(2)	500 x 260 x 400	420 x 205 x 320	1	5

EAN = 4005187 + Art. Nr. ohne führende „4“ + Prüfziffer (X) / EAN = 4005187 + Art. No. without leading “4” + check digit (X)



Aluminium, Holz, Kunststoff, Stahlblech, Textilien / Aluminium, wood, plastic, sheet steel, textile

Alu-Rahmen Service- und Montagekoffer mit praktischen Tableaus

Die funktionellen Koffer im modernen Design, bestehen aus einem breiten, runden Alu-Rahmen mit Kunststoff- und Textil-Applikationen. Zahlreiche Fächer, herausnehmbare Trennwände (Sortimentskästen inklusive) und aufstellbare Werkzeughalter ermöglichen eine individuelle Aufbewahrung. Die Werkzeughalter haben einen innovativen Bürstenhalter und die Möglichkeit, und ist beidseitig mit Textiltaschen bestückt.

Aluminium-frame field service & technicians cases with useful organiser panels

These modern, functionally designed cases feature a large, rounded aluminium frame with plastic and textile applications. They are handy and sturdy helpers at work and on the go! Numerous compartments, removable partitions (assortment boxes included) and deployable tool holders ensure customised organisation. The tool holders have an innovative brush holder and can be equipped with textile bags on both sides.



Abkippbarer Trolley
Tilting trolley



Robustes Gehäuse mit stabilen Schutzecken
Tough frame with sturdy reinforced corners



Trennwand individuell verstellbar
Partition individually adjustable



Tragegurt als Zubehör erhältlich (siehe S. 38)
Carrying strap available as an accessory (see p. 38)



Zahlenschloss, komfortabler Griff
Combination locks, comfortable handle

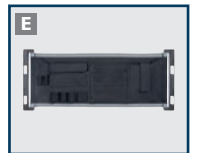

1/2
Passendes Zubehör, (siehe S. 22/23)
Matching accessories, (see p. 22/23)



mm



mm



1	AluPlus Service >C<50-2	427350(2)		500 x 265 x 405	460 x 210 x 360	1	5
2	AluPlus Service >RC<50-3	427355(7)		500 x 300 x 475	460 x 210 x 360	1	5

EAN = 4005187 + Art. Nr. ohne führende „4“ + Prüfziffer (X) / EAN = 4005187 + Art. No. without leading “4” + check digit (X)

Alu-Rahmen Service- und Montagekoffer

Die funktionellen Koffer im modernen Design bestehen aus einem breiten, runden Alu-Rahmen mit Kunststoff- und Textil-Applikationen. Zahlreiche Fächer und flexible Trennstege oder Einsatzboxen ermöglichen eine individuelle Aufbewahrung. Sichere Sortierung: herausnehmbare Einsatzboxen von Service ›C‹ 44-3 schließen fest mit dem Deckel ab.

Aluminium-frame field service & technicians cases

These modern, functionally designed aluminium frame cases featuring a large, rounded aluminium frame with plastic and textile appliqué are handy and sturdy helpers at work and on the go! Numerous compartments and flexible dividers or bins ensure customised organisation. Safe and secure organisation: The lid of Service ›C‹ 44-3 provides a tight seal for the removable internal containers.



Verbesserter Griff mit Tragegurt-Ösen
Optimised handle with lugs for carrying strap

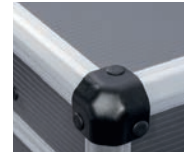

Kratzfeste Kunststoffecken bieten dem Koffer stabilen Schutz
Scratch-resistant plastic corner guards provide perfect protection



Alle Koffer mit optimierten Zahlenschlössern
All cases are equipped with optimised combination locks



Fächerartige Werkzeugtableaus
Fold-down (fanlike) tool panels



Arretierbare Kunststoff-Trennstege in Schwalbenschwanzführung
Plastic slide-in dividers in dovetailed guides for neat compartments



Herausnehmbare Insertboxen (siehe S. 78)
Removable insert boxes (see p. 78)



3



2



	EAN	Check digit	Dimensions (mm)	Dimensions (mm)	Quantity	Quantity
1	AluPlus Service ›C‹44-1	427210(9)	445 x 370 x 210	405 x 305 x 190	1	5
2	AluPlus Service ›C‹44-2	427220(8)	445 x 370 x 210	405 x 305 x 190	1	5
3	AluPlus Service ›C‹44-3	427250(5)	445 x 370 x 210	405 x 305 x 190	1	5

EAN = 4005187 + Art. Nr. ohne führende „4“ + Prüfziffer (X) / EAN = 4005187 + Art. No. without leading “4” + check digit (X)



Passendes Zubehör (siehe S. 22/23)
Matching accessories (see p. 22/23)

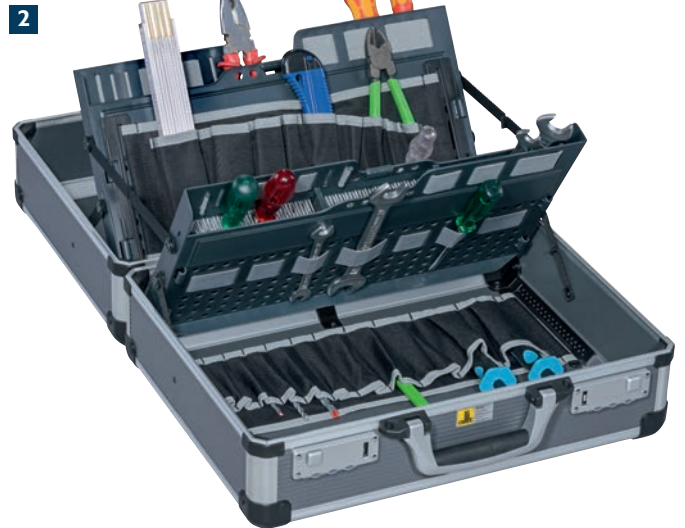
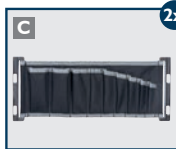
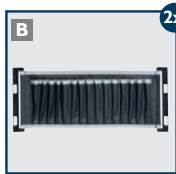

EuroPlus Insert S. 78
EuroPlus Insert p. 78

Werkzeugkoffer und -taschen und Transportkoffer.

Das Sortiment zeigt eine Bandbreite aus Kunststoff, Aluminium, Metall und Textil und bietet damit eine große Vielfalt zur Organisation und Aufbewahrung im Betrieb, auf Montage oder im Serviceeinsatz.

Whether it is tool cases or tool bags or transport cases – the range of useful storage aids featuring a carefully selected array of materials, such as plastic, aluminium, metal and textile, provides innumerable options for smart organisation and storage, not only on the shop floor and in the workshop, but also in transit and in the field.



DinoPlus Outdoor

30



AluPlus Protect ›C‹

34



AluPlus Tool ›C‹

35



AluPlus Tool ›L‹

36



AluPlus Basic ›L‹

37

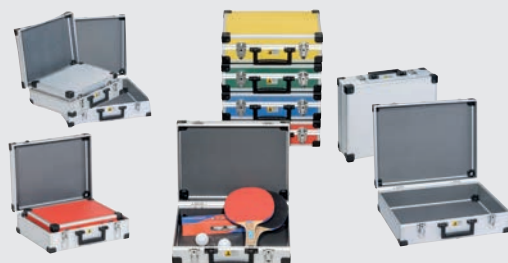

AluPlus Foam & Strap

38



DinoPlus Tool, Hobby & Metall

39



McPlus Pro »M«

40



McPlus Pro Alu

41



McPlus Alu »C« 18 & 22
McPlus Alu 17.8, 21 & 25

42

43



McPlus Depot »S« & Promo »S«

44



McPlus Promo »SL«
McPlus Promo

45

46



McPlus Mobile »P«

47



McPlus Clear

48



McPlus Workman
McPlus Carry

49

50



McPlus Metall
McPlus Bag

51

52



Stabile Universalkoffer für sichere Transporte in unterschiedlichsten Anwendungsbereichen.

Die widerstandsfähigen Universalkoffer aus ABS oder Polypropylen sind für sichere Transporte in unterschiedlichsten Anwendungsbereichen hilfreich. Die Staub- und wasserdichten Schutzkoffer haben eine nahtlose, umlaufende Gummidichtung gem. Schutzklasse IP67 mit automatischem Druckausgleichsventil. Somit kann der DinoPlus Outdoor Koffer für viele Transporte nützlich sein, z. B. Messinstrumente, Kameras, Geräte, Camping, Angeln, Wassersport und viele weitere Outdoor-Aktivitäten. Die Innenausstattung besteht entweder aus Raster- und Noppenschaumstoff oder aus gepolsterten Trennstegen für individuelle Facheinteilungen.

Stable universal case for safe transport in a wide variety of applications.

The robust universal cases made of ABS or polypropylene are helpful for safe transport in a wide variety of applications. The dust and waterproof protective cases have a seamless, all-round rubber seal according to protection class IP67 with an automatic pressure equalization valve. Thus, the DinoPlus Outdoor suitcase can be useful for many transports, e.g. B. Measuring instruments, cameras, devices, camping, fishing, water sports and many other outdoor activities. The interior consists either of grid and nub foam or of padded dividers for individual compartments.



Staubdicht und hält Wasser für einen gewissen Zeitraum ab
Dustproof and keeps water out for a period of time





ABS-Kunststoff, Schaumstoff / ABS-plastic, foam

Ausstattungsvielfalt DinoPlus Outdoor / Variety DinoPlus Outdoor

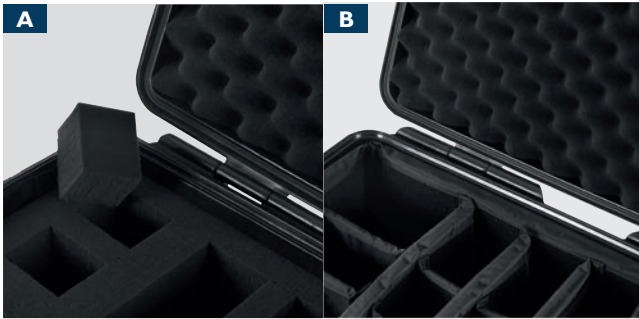

A
Würfelschaum für jeweiligen Inhalt
anpassbar
Cube foam for each Content customi-
zable

B
Separate Aufteilungen durch gepolsterte
Trennsteg
Separate divisions through padded
dividers



Hoher Tragekomfort durch Anbringung eines Schultergurtes
High wearing comfort by attaching a Shoulder strap



Zweistufige Sicherheitsverschlüsse
Two-stage safety locks



Automatisches Druckausgleichs-Ventil für ein einfaches Öffnen
Automatic Pressure equalization valve for easy opening



Ausziehbarer Teleskopgriff sorgt für ein bequemes Handling
Extendable telescopic handle ensures comfortable handling



Zwei Leichtlaufrollen sorgen für einfaches transportieren
Two smooth running castors ensure easy transport



Schaumstoff im Deckel für erweiterten
Schutz des Inhaltes
Foam in the lid for extended protection
of the content

Universalkoffer aus ABS oder PP für sichere Transporte in unterschiedlichsten Anwendungsbereichen

Die schlagfesten Universalkoffer stechen durch ihre robusten Fähigkeiten gerade im Außenbereich hervor. Durch ihre kompakte Größe eignen sie sich ideal zur Aufbewahrung und Transport für Messinstrumente, Kameras, Geräte sowie Angeln und viele weiteren Aktivitäten.

Universal case made of ABS or PP for safe transport in a wide range of applications

The impact-resistant universal cases stand out due to their robust capabilities, especially outdoors. Due to their compact size, they are ideal for storing and transporting measuring instruments, cameras, equipment, as well as fishing and many other activities.



Würfelschaum für jeweiligen Inhalt anpassbar
Cube foam for each Content customizable



Hoher Tragekomfort durch Anbringung eines Schultergurtes
High wearing comfort by attaching a Shoulder strap



Zweistufige Sicherheitsverschlüsse
Two-stage safety locks



Aus ABS-Kunststoff
Made of ABS-plastic



Automatisches Druckausgleichs-Ventil für ein einfaches Öffnen
Automatic Pressure equalization valve for easy opening



Mit handelsüblichem Vorhängeschloss abschließbar
Lockable with a standard padlock

Zubehör: DinoPlus Outdoor

Equipment: DinoPlus Outdoor



Passend zu DinoPlus Outdoor >F< 11



Passend zu DinoPlus Outdoor >F< 18

Schultergurt ist längenverstellbar
Shoulder Strap is adjustable in length



Passender Schultergurt inklusive.
Matching shoulder strap included.



mm



mm



1	DinoPlus Outdoor >F< 9	458800(2)		225 x 180 x 85	190 x 130 x 71	1	5
2	DinoPlus Outdoor >F< 9	458801(9)		225 x 180 x 85	190 x 130 x 71	1	5
3	DinoPlus Outdoor >F< 11	458810(1)		275 x 225 x 155	225 x 160 x 138	1	5
4	DinoPlus Outdoor >F< 11	458811(8)		275 x 225 x 155	225 x 160 x 138	1	5
5	DinoPlus Outdoor >F< 18	458830(9)		455 x 370 x 185	385 x 270 x 160	1	5
6	DinoPlus Strap M	458890(3)		1350 x 45 x 10	-	1	5
7	DinoPlus Strap L	458891(0)		1430 x 85 x 13	-	1	5

EAN = 4005187 + Art. Nr. ohne führende „4“ + Prüzfiffer (X) / EAN = 4005187 + Art. No. without leading “4” + check digit (X)



Rollbare Universalkoffer für sichere Transporte in unterschiedlichsten Anwendungsbereichen

Die widerstandsfähigen Schutzkoffer bieten eine Menge Platz und eignen sich hervorragend für Messinstrumente, Kameraequipment, sensible Geräte wie auch für Wassersport, Camping und vielem mehr. Der ausziehbarer Teleskopgriff und die Leichtlaufrollen bieten ein überaus hohes Handling im Transport.

Rollable universal cases for safe transport in a wide range of applications

The resistant protective cases offer a lot of space and are ideal for measuring instruments, camera equipment, sensitive devices as well as water sports, camping and much more. The extendable telescopic handle and the smooth-running wheels offer extremely easy handling during transport.



10 Separate Aufteilungen durch gepolsterte Trennstege
Separate divisions through padded dividers



Ausziehbarer Teleskopgriff sorgt für ein bequemes Handling
Extendable telescopic handle ensures comfortable handling



Zweistufige Sicherheitsverschlüsse
Two-stage safety locks



Mit handelsüblichem Vorhängeschloss abschließbar
Lockable with a standard padlock



Automatisches Druckausgleichs-Ventil für ein einfaches Öffnen
Automatic Pressure equalization valve for easy opening



Zwei Leichtlaufrollen sorgen für einfaches Transportieren
Two smooth running castors ensure easy transport



8



10

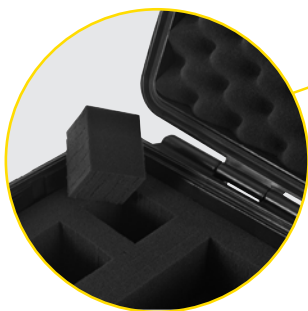

9



mm



mm



8	DinoPlus Outdoor >FR< 24W	458850(7)		600 x 440 x 285	500 x 345 x 245	1	5
9	DinoPlus Outdoor >FR< 26	458860(6)		665 x 495 x 340	545 x 405 x 295	1	5
10	DinoPlus Outdoor >DR< 26	458865(1)		665 x 495 x 340	545 x 405 x 295	1	5

EAN = 4005187 + Art. Nr. ohne führende „4“ + Prüfziffer (X) / EAN = 4005187 + Art. No. without leading “4” + check digit (X)

Alu-Rahmen Instrumenten-, Messgeräte- oder Kamerakoffer

Die edlen Koffer, bestehend aus einem breiten, runden Alu-Rahmen mit Kunststoff-Applikationen, sind speziell konzipiert für den sicheren Transport empfindlicher Geräte, z. B. von Messinstrumenten. Die komplett gepolsterten Koffer eignen sich optimal als Verpackung von optischen Geräten, Kameras, etc.

Aluminium-frame carrying cases for instruments, measuring devices or cameras

Specially designed cases for the safe & secure transport of sensitive devices such as measuring instruments. The cases are fully padded, which makes them suitable also for transporting or storing optical devices, cameras.



Verbesserter Griff mit Tragegurt-Ösen
Optimised handle with lugs for carrying strap



Alle Koffer mit Zahlenschlössern
All cases are equipped with combination locks



Kratzfeste Kunststoff-ecken bieten dem Koffer stabilen Schutz
Scratch-resistant plastic corner guards provide perfect protection

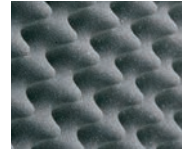

Schaumstoffeinlage im Deckel
Foam insert in the lid

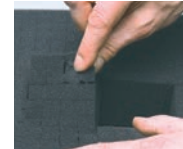

Schaumstoffwürfel im Unterteil einzeln entnehmbar
The foam cubes in the bottom part can be individually removed



Tragegurt als Zubehör erhältlich (Seite 38)
Carrying strap as accessory available (see p. 38)

Make Your Case



Ersatz für **2**:
AluPlus Foam 44/2 (S. 38)
Replacement for **2**:
AluPlus Foam 44/2 (p. 38)



mm



mm



1	AluPlus Protect >C< 36	425805(9)	355 x 325 x 135	320 x 260 x 120	2	5
2	AluPlus Protect >C< 44	425810(3)	445 x 370 x 145	405 x 305 x 125	2	5
3	AluPlus Protect >C< 60	425820(2)	605 x 370 x 145	565 x 305 x 125	1	5
4	AluPlus Protect >C< 120	425830(1)	1205 x 370 x 145	1165 x 305 x 125	1	5

EAN = 4005187 + Art. Nr. ohne führende „4“ + Prüfziffer (X) / EAN = 4005187 + Art. No. without leading “4” + check digit (X)



Alu-Rahmen Werkzeugkoffer mit C-Profil

Die edlen Koffer, bestehend aus einem breiten, runden Alu-Rahmen mit Kunststoff- und Textil-Applikationen, sind praktische und stabile Helfer im Betrieb oder beim Transport von Werkzeugen. Die Innenausstattung des Koffers besteht aus Kunststoffbauteilen und ist nachträglich austauschbar (siehe S. 38).

Aluminium-frame tool cases with C-profile

These premium cases featuring a large, rounded aluminium frame with plastic and textile appliques are handy and sturdy helpers at work and on the go! Whether on the shop floor or in transit, they are ideal for carrying tools. The interiors of the case also consist of plastic components (complementary accessories available, see page 38).



Verbesserter Griff mit Tragegurt-Ösen
Optimised handle with lugs for carrying strap



Kratzfeste Kunststoffecken bieten dem Koffer stabilen Schutz
Scratch-resistant plastic corner guards provide perfect protection



Stabile, abschließbare Spannbügelverschlüsse aus Stahlblech
Sturdy, key-lockable draw latches made of sheet steel



Robuster, flexibler Textil-Werkzeughalter
Tool holder made of textile – robust and flexible

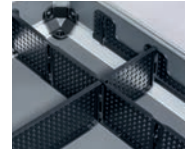

Arretrierbare Kunststoff-Trennsteg in Schwalbenschwanzführung
Plastic slide-in dividers in dovetailed guides for neat compartments



Ab einer Mindestmenge nach Ihren Wünschen individualisierbar
Starting from the minimum order quantity, the cases are customisable

Raster- und Noppenschaumstoff (siehe S. 38)
Napped and padded foam (see p. 38)



Make Your Case



mm



mm



1	AluPlus Tool >C< 36	426100(4)		355 x 325 x 135	320 x 260 x 120	2	a.A.*
2	AluPlus Tool >C< 44	426200(1)		445 x 370 x 145	405 x 305 x 125	2	5
3	AluPlus Tool >C< 47C	426320(6)		455 x 230 x 330	420 x 190 x 185	1	a.A.*
4	AluPlus Foam 44/2	420930(3)		430 x 330 x 120	-	1	5

EAN = 4005187 + Art. Nr. ohne führende „4“ + Prüfziffer (X) / EAN = 4005187 + Art. No. without leading “4” + check digit (X)

* a.A. = auf Anfrage / Upon request

Alu-Rahmen-Werkzeugkoffer mit L-Profil

Die robusten Koffer mit Kunststoff- und Textil-Applikationen, sind praktische und stabile Helfer im Betrieb oder beim Transport von Werkzeugen. Die Innenausstattung besteht aus Kunststoffbauteilen, z. B. dem Schwalbenschwanz-Trennsteghalter. Der hochwertige Alu-Rahmen-Koffer ist mit Zubehör ergänzungsfähig (siehe S. 38).

Aluminium-frame tool cases with L-profile

These robust cases with plastic and textile applications are handy and sturdy helpers at work and on the go! Whether on the shop floor or in transit, they are ideal for carrying tools. The interiors (e.g. the dove-tailed divider holders) also consist of plastic components. The high-quality aluminium frame has complementary accessories (see page 38).



Verbesserter Griff mit Tragegurt-Ösen
Optimised handle with lugs for carrying strap



Kratzfeste Kunststoffecken bieten dem Koffer stabilen Schutz
Scratch-resistant plastic corner guards provide perfect protection



Stabile, abschließbare Spannbügelverschlüsse aus Stahlblech
Sturdy, key-lockable bracket fasteners made of sheet steel



Arretierbare Kunststoff-Trennsteg in Schwalbenschwanzführung
Plastic slide-in dividers in dovetailed guides for neat compartments



Robuster, flexibler Textil-Werkzeughalter
Tool holder made of textile – robust and flexible



Erweiterbar mit AluPlus Foam 44/2 (siehe S. 38)
Extensible with AluPlus Foam 44/2 (see p. 38)

Make Your Case

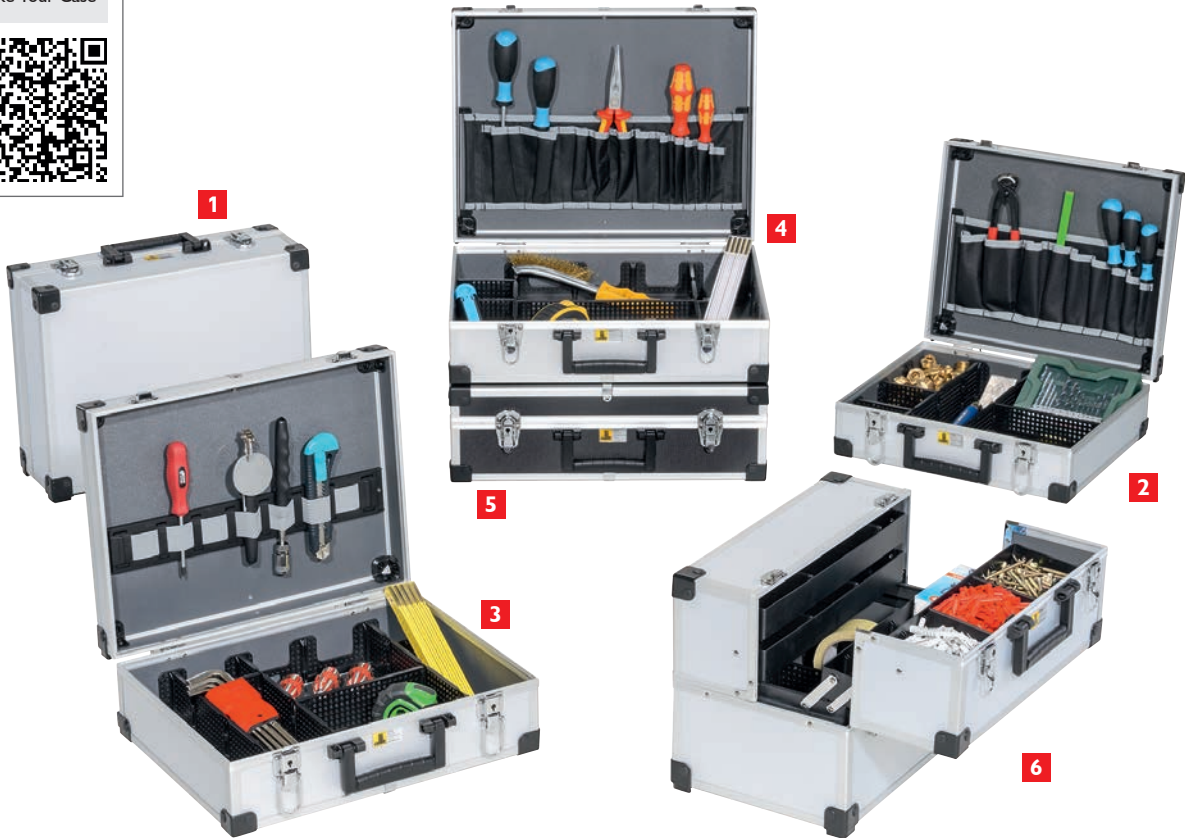

mm



mm



	EAN	Wrench	L-profile	mm	Cube	mm	Box	Truck
1 AluPlus Tool >L< 36	425100(5)			360 x 315 x 130	340 x 285 x 110	4	5	
2 AluPlus Tool >L< 40	425150(0)			395 x 315 x 140	380 x 285 x 125	4	a.A.*	
3 AluPlus Tool >L< 40-1	425151(7)			395 x 315 x 140	380 x 285 x 125	4	a.A.*	
4 AluPlus Tool >L< 44-1	425200(2)			445 x 355 x 145	425 x 325 x 130	2	5	
5 AluPlus Tool >L< 44-2	425201(9)			445 x 355 x 145	425 x 325 x 130	2	5	
6 AluPlus Tool >L< 36C	425300(9)			365 x 230 x 275	345 x 210 x 140	2	5	

EAN = 4005187 + Art. Nr. ohne führende „4“ + Prüzfiffer (X) / EAN = 4005187 + Art. No. without leading “4” + check digit (X)

* a.A. = auf Anfrage / Upon request



Alu-Rahmen Utensilien-, Hobby- und Verpackungskoffer

Die schicken Koffer, bestehend aus einem Alu-Rahmen mit Kunststoff-Applikationen, sind praktische und stabile Helfer als Verpackung, im Haushalt, beim Hobby oder beim Transport von Utensilien. Der hochwertige Koffer ist in vier Standardgrößen erhältlich und mit Zubehör ergänzungsfähig (siehe S. 38).

Aluminium-frame utensil & packing cases

These stylish aluminium frame cases with plastic applications are handy and sturdy helpers at work and anywhere else! Whether in household, hobby or in transit, they are ideal for packaging and carrying utensils. The high-quality aluminium frame is available in four standard sizes, and complementary accessories are available (see page 38).



Verbesserter Griff mit Tragegurt-Ösen
Optimised handle with lugs for carrying strap



Kratzfesteste Kunststoffecken bieten dem Koffer stabilen Schutz
Scratch-resistant plastic corner guards provide perfect protection



Stabile, abschließbare Spannbügelverschlüsse aus Stahlblech
Sturdy, key-lockable draw latches made of sheet steel



Weitere Farben auf Anfrage möglich
Other colours available on request.



Make Your Case



Erweiterbar mit AluPlus Foam 44/2 (siehe S. 38)
Extensible with AluPlus Foam 44/2 (see p. 38)

AluPlus Basic >L< 35	
	424100 (6)
	424110 (5)
	424120 (4)
	424130 (3)
	424140 (2)

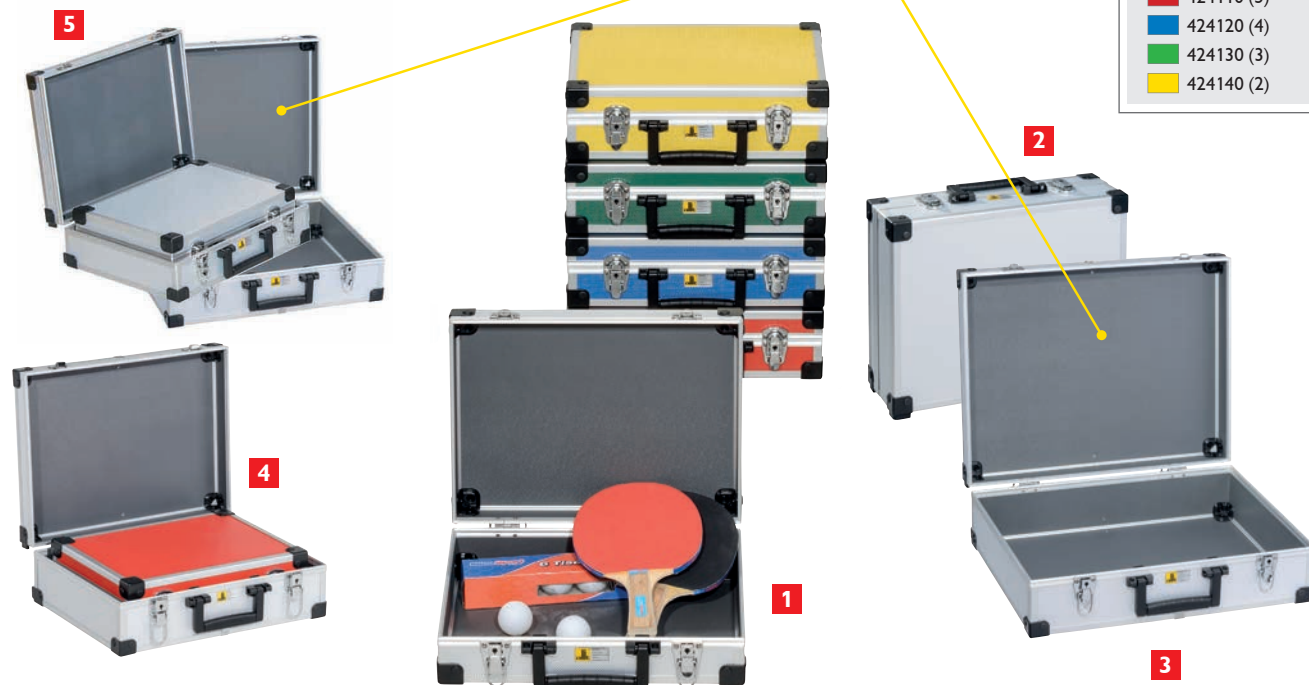

1 AluPlus Basic >L< 35	424100(6)		345 x 285 x 105	330 x 245 x 90	4	5
2 AluPlus Basic >L< 38	424150(1)		375 x 315 x 130	360 x 285 x 110	4	a. A.*
3 AluPlus Basic >L< 44	424200(3)		445 x 355 x 145	425 x 325 x 130	2	5
4 AluPlus Basic >L< 2i1	424202(7)		395 x 315 x 140	380 x 285 x 125	2	a. A.*
5 AluPlus Basic >L< 3i1	424203(4)		445 x 355 x 145	425 x 325 x 130	2	a. A.*

EAN = 4005187 + Art. Nr. ohne führende „4“ + Prüfziffer (X) / EAN = 4005187 + Art. No. without leading “4” + check digit (X)

* a. A. = Auf Anfrage / Upon Request

Noppen- und Rasterschaumstoff

Zweiteiliges Schaumstoff-Set als optionales Zubehör oder Erweiterung für AluPlus Koffer der Größe 44. Ideal zum Schutz empfindlicher Messinstrumente, Instrumente oder Sportgeräte.

Napped foam and pick & pluck grid padding

2-parted Foam set as optional accessories or extension for AluPlus cases size 44. Ideal for transporting sensitive tools (e.g. measuring instruments or other devices, sports equipment etc.).



1

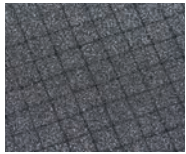

Schaumstoffzapfen im Unterteil an Konturen anpassbar

Foam cubes in the lower shell are adaptable to the contours

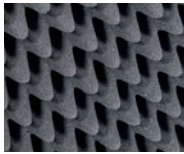

Schaumstoffeinlage für das Oberteil
Foam for upper shell

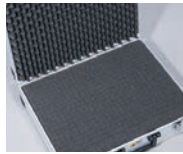

Optionales Zubehör für AluPlus Koffer der Größe 44

Optional accessories for AluPlus cases size 44

Tragegurt

Textiltragegurt als optionales Zubehör oder Erweiterung für AluPlus Koffer. Variabel in der Länge verstellbar bis 140 cm.

Carrying Strap

Carrying strap as optional accessories or extension for AluPlus cases. Variable in length of strap up to 140 cm.



Mit zwei verchromten Karabinerhaken

With two chromed hooks



Mit Schulterpolster
With shoulder pad

2



Passend für / suitable for:

AluPlus Foam	Protect ›C‹ 425810	Tool ›C‹ 426200	Tool ›L‹ 425200 425201	Basic ›L‹ 424200
AluPlus Strap	AluPlus Service ›C‹	Tool ›C‹	Tool ›L‹	Basic ›L‹



1	AluPlus Foam	420930(5)		430 x 330 x 120	1	5
2	AluPlus Strap	420910(5)		830 x 40 x 1,5	1	5

EAN = 4005187 + Art. Nr. ohne führende „4“ + Prüfziffer (X) / EAN = 4005187 + Art. No. without leading “4” + check digit (X)



Metall / Metal

Metall- und Kunststoffkoffer

Als Universalkoffer vielseitig einsetzbar bieten die stabilen Metall- und Kunststoffkoffer Ordnung und Übersicht als Verpackung, im Haushalt, beim Hobby oder beim Transport von Utensilien. Stabile Schnappverschlüsse und Schaumstoffeinlagen schützen den Inhalt.

Metal- and plastic case

These sturdy plastic cases are perfect all-rounders: Whether used as packaging containers, as storage helpers in the household or in leisure pursuits, or as transport aids for equipment on the move, the cases will provide perfect order and overview. Robust snap locks and form inserts protect the items inside.



Schaumstoff schützt den Inhalt
Foam lining protects the items inside

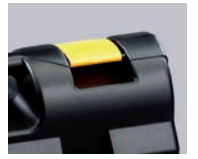

Stabile Verschlüsse aus Kunststoff
Sturdy plastic closures



Ergonomischer Griff
Ergonomic handle



Sortierkasten im Deckel
Assortment Box in the lid

1



2



3



4



5



EuroPlus Basic 18/7

6



Weitere Koffer (EuroPlus Pro >K< 44.144, EuroPlus MetaBox) für großzügige Unterbringung finden Sie ab S. 56.

Additional cases (EuroPlus Pro >K< 44.144, EuroPlus MetaBox) for generous accommodation can be found on p. 56.



	EAN	Color	Dimensions (mm)	Dimensions (mm)	Dimensions (mm)	Weight (kg)	Volume (L)
1	DinoPlus Tool 41	458600(8)		410 x 320 x 155	385 x 240 x 100	2	5
2	DinoPlus Tool >F< 41	458601(5)		410 x 320 x 155	385 x 240 x 100	2	5
3	DinoPlus Hobby 3000 DD	458680(0)		410 x 320 x 155	385 x 240 x 120	2	5
4	DinoPlus Metall 33	490610(3)		335 x 255 x 115	325 x 225 x 105	1	5
5	DinoPlus Pro >M< 41	490634(9)		410 x 295 x 330	385 x 265 x 325	1	5
6	DinoPlus Hobby 3000 AA	458685(5)		400 x 320 x 120	380 x 230 x 115	5	5

EAN = 4005187 + Art. Nr. ohne führende „4“ + Prüfziffer (X) / EAN = 4005187 + Art. No. without leading “4” + check digit (X)

Edelstahl-Kunststoff-Werkzeugkoffer mit Metallverschlüssen

Hochwertige und robuste Profi-Werkzeugkoffer mit geringem Eigengewicht, geeignet auch für den Transport schwerer Werkzeuge. Die herausnehmbaren Tragekästen erhöhen das Nutzvolumen für sperrige Maschinen und Geräte im Kofferinneren.

Stainless steel & plastic tool case with metal latches

High-quality and robust professional tool cases with low weight, suitable also for transporting heavy tools. The tote trays are removable; this increases usability even for bulky power tools and devices stored inside the case!



Herausnehmbare Einsatzboxen im Deckel
Lift-out insert bins in the lid



Stabile Spannbügelverschlüsse aus Metall
Sturdy metal bracket latches



Mit handelsüblichem Vorhängeschloss abschließbar
Lockable with a standard padlock



Solider Alu-Bügelgriff
Solid aluminium bow handle



Stufenlos höhenverstellbarer Trolley
Continuously adjustable trolley



Metallmantel
Metal frame



mm



mm



1	McPlus Pro >M< 20	476410(9)		505 x 235 x 255	470 x 180 x 135	1	5
2	McPlus Pro >M< R25L+23	476450(5)		620 x 370 x 655	490 x 245 x 225	1	5

EAN = 4005187 + Art. Nr. ohne führende „4“ + Prüzfiffer (X) / EAN = 4005187 + Art. No. without leading “4” + check digit (X)



Aluminium, Weich-PVC / Aluminium, soft PVC

Profi-Kunststoff-Werkzeugkoffer mit geschlossener Deckelkonstruktion

Die Werkzeugkoffer bieten dem Profi einen kompletten und mobilen Arbeitsplatz. Trotz kompakter Abmessungen bieten sie größtmögliches Volumen und Stauraum. Stabilere, geschlossene Deckelkonstruktion als bei McPlus Alu. Profiqualität aus stabilem und bruchsicherem Polypropylen sowie hitze- und kältebeständig (+45 ° bis -5° Grad)

Professional plastic tool case with closed lid construction

These tool cases provide professionals with a fully equipped and mobile workstation. Despite their compact dimensions, they offer a maximum of space. Sturdier, closed lid construction as McPlus Alu. Professional quality of stable and break-resistant polypropylene and hot- and cold-resistant (+45° to -5° degrees).

1



Stabile Spannbügelverschlüsse aus Aluminium
Sturdy aluminium draw latches



Bügelgriff aus Aluminium
Aluminium handle for safe carrying



Optimaler Zugriff auf Kofferinhalte durch Cantilever
Cantilever design for optimum access to the items inside



In geschlossenem Zustand formschlüssig
Tightly fits when closed



Mit handelsüblichem Vorhängeschloss abschließbar
Lockable with a standard padlock



Sortimentskästen im Deckel
Assortment boxes integrated in the lid

2



1 **McPlus ProAlu>C<18**

457031(1)



475 x 255 x 215

395 x 175 x 90

2

5

2 **McPlus ProAlu>C<22**

457033(5)



565 x 285 x 280

485 x 200 x 130

2

5

EAN = 4005187 + Art. Nr. ohne führende „4“ + Prüfziffer (X) / EAN = 4005187 + Art. No. without leading “4” + check digit (X)

Profi-Kunststoff-Werkzeugkoffer mit offener Deckelkonstruktion

Die Werkzeugkoffer bieten dem Profi, aber auch dem anspruchsvollen Hobby-Handwerker, einen kompletten und mobilen Arbeitsplatz. Trotz kompakter Abmessungen bieten sie größtmögliches Volumen und Stauraum. Die offene Deckelkonstruktion ermöglicht einen Blick auf die enthaltenen Sortimentskästen.

Professional plastic tool case with an open lid construction

These tool cases provide both professionals and exacting DIY enthusiasts with a fully equipped and mobile workstation. Despite their compact dimensions, they offer a maximum of space. The open lid construction allows a look at the included assortment boxes.



Sortimentskästen im Deckel
Assortment boxes integrated in the lid



Stabile Spannbügelverschlüsse aus Aluminium
Sturdy aluminium draw latches



Bügelgriff aus Aluminium
Aluminium handle for safe carrying



Mit handelsüblichem Vorhängeschloss abschließbar
Lockable with a standard padlock



Optimaler Zugriff auf Kofferinhalte durch Cantilever
Cantilever design for optimum access to the items inside



In geschlossenem Zustand formschlüssig
Flush fit when closed



mm



mm



1	McPlus Alu >C< 18	457011(3)		470 x 255 x 215	395 x 175 x 90	2	5
2	McPlus Alu >C< 22	457021(2)		560 x 285 x 280	485 x 200 x 130	2	5

EAN = 4005187 + Art. Nr. ohne führende „4“ + Prüfziffer (X) / EAN = 4005187 + Art. No. without leading “4” + check digit (X)



Aluminium, TPE / Aluminium, TPE

McPlus Alu 17.8, 21 & 25

Profi-Kunststoff-Werkzeugkoffer mit Alu-Griffen und -Verschlüssen

Die Koffertypen überzeugen durch ihr solides Design. Säulenartige Ecken sowie der „Ringanker“, der bei den McPlus Alu 21 und McPlus Alu 25 für den perfekten Sitz des Tragekastens sorgt, bieten große Stabilität bei größtmöglichem Raumnutzen.

Professional plastic tool box with aluminium handles and latches

Both case types impress with their solid design. Column-shaped corners as well as the circumferential reinforcement ring, which ensures perfect stability of McPlus Alu 21 and McPlus Alu 25, provide great stability whilst allowing maximum space utilisation.



Stabile Spannbügelverschlüsse aus Aluminium
Sturdy aluminium bracket latches

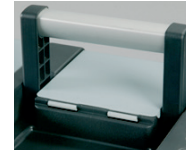

Komfortabler Tragegriff aus Aluminium
Comfortable aluminium carrying handle

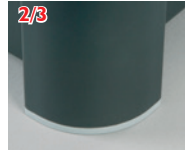

Füße aus thermoplastischem Elastomer (TPE)
Feet made of thermoplastic elastomer (TPE)











In geschlossenem Zustand formschlüssig
Fits tightly when closed



Mit handelsüblichem Vorhängeschloss abschließbar
Lockable with a standard padlock



			 mm	 mm		
1 McPlus Alu 17.8	457017(5)		450 x 225 x 200	400 x 165 x 100	2	5
2 McPlus Alu 21	457018(2)		530 x 250 x 250	450 x 170 x 130	2	5
3 McPlus Alu 25	457022(9)		640 x 290 x 295	550 x 205 x 150	1	5

EAN = 4005187 + Art. Nr. ohne führende „4“ + Prüfwert (X) / EAN = 4005187 + Art. No. without leading “4” + check digit (X)

Kunststoff-Werkzeugkofferdepot mit Metallverschlüssen

Wahre Ordnungswunder für unterwegs: Neben reichlich Platz – auch für sperrige Werkzeuge – bieten die im Deckel und im Boden integrierten Sortimentskästen sowie das Werkzeugtray viele Fächer für Kleinteile und Material.

Plastic tool case depot with metal latches

Works real wonders on the move: Offers abounding space – also for bulky tools. The assortment boxes integrated in the top and the bottom as well as the tool tray feature many different compartments for small parts and material.



1/3/4
Herausnehmbare Bit- / Bohrerbox im Deckel
Removable bit/drill box in the lid



1
4 Herausnehmbare Sortimentskästen im Boden
Lift-out assortment boxes in the bottom



1
Verriegelung verhindert Herausrutschen
Locking mechanism prevents slip-out



2/3
Fächer für Kleinteile im Deckel
Small parts compartments in the lid



1/4
2 herausnehmbare Sortimentskästen im Deckel
2 removable assortment boxes in the lid



Stabile Spannbügelverschlüsse aus Metall
Sturdy metal bracket latches



1
Individuelle Einteilung der Fächer der Sortimentskästen
Customised compartments in the assortment boxes



3
Individuelle Einteilung der Fächer im Deckel
Customised lid compartments



mm



mm



	EAN	Screwdriver	L-shaped	mm	Cube	mm	Box	Truck
1 McPlus Depot >S< 23	476320(1)	■	■	580 x 280 x 330	485 x 210 x 160	1	5	
2 McPlus Promo >S< 16	476280(8)	■	■	400 x 220 x 200	345 x 150 x 95	4	5	
3 McPlus Promo >S< 20	476260(0)	■	■	510 x 240 x 250	450 x 165 x 110	4	5	
4 McPlus Promo >S< 23	476221(1)	■	■	580 x 280 x 280	485 x 210 x 160	2	5	

EAN = 4005187 + Art. Nr. ohne führende „4“ + Prüzfiffer (X) / EAN = 4005187 + Art. No. without leading “4” + check digit (X)



Kunststoff-Werkzeugkoffer mit Metallverschlüssen

Der Werkzeugkoffer mit Metallverschlüssen für den Hobby-Handwerker und Heimwerker mit den Eigenschaften eines Profi-Werkzeugkoffers.

Plastic tool cases with metal latches

The tool box with metal latches for the DIY enthusiast offering all features of a professional tool box.



3
2 herausnehmbare Sortimentskästen im Deckel
2 removable assortment boxes in the lid

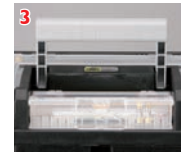

3
Herausnehmbare Bit-/Bohrerbox im Deckel
Removable bit/drill box in the lid



1/2
Fächer für Kleinteile im Deckel
Small parts compartments in the lid



Stabile Spannbügelverschlüsse aus Metall
Sturdy metal bracket latches



Mobiler Tragekasten zur Werkzeug- und Kleinteileaufbewahrung
Sturdy tote tray for the storage of tools and small parts

				mm		mm		
1 McPlus Promo >SL< 16	476233(4)		400 x 220 x 200	345 x 155 x 125	8	5		
2 McPlus Promo >SL< 20	476243(3)		510 x 240 x 250	450 x 165 x 110	6	5		
3 McPlus Promo >SL< 23	476253(2)		580 x 280 x 280	485 x 210 x 160	6	5		

EAN = 4005187 + Art. Nr. ohne führende „4“ + Prüfziffer (X) / EAN = 4005187 + Art. No. without leading “4” + check digit (X)

Kunststoff-Werkzeugkoffer

Der Werkzeugkoffer für den Hobby-Handwerker und Heimwerker mit den Eigenschaften eines Profi-Werkzeugkoffers.

Plastic tool cases

Practically designed tool cases for exacting hobby crafters and DIY enthusiasts.



4
2 herausnehmbare Sortimentskästen im Deckel
2 removable assortment boxes in the lid



4
Herausnehmbare Bit- / Bohrerbox im Deckel
Removable bit/drill box in the lid



1-3
Fächer für Kleinteile im Deckel
Small parts compartments in the lid



1/2
Trageschale zur Aufbewahrung von Kleinteilen
Carrying tray for small parts



3/4
Mobiler Tragekasten zur Werkzeug- und Kleinteileaufbewahrung
Mobile tote tray for the storage of tools and small parts



Schneller Umschlag als Zweitplatzierung
Fast turnaround as a secondary placement



			mm	mm		
1 McPlus Promo 12.5	476190(0)		310 x 170 x 130	265 x 130 x 60	6	5
2 McPlus Promo 16	476180(1)		400 x 220 x 200	345 x 155 x 125	4	5
3 McPlus Promo 20	476160(3)		510 x 240 x 240	450 x 165 x 110	4	5
4 McPlus Promo 23	476120(7)		580 x 280 x 280	485 x 210 x 160	2	5

EAN = 4005187 + Art. Nr. ohne führende „4“ + Prüfziffer (X) / EAN = 4005187 + Art. No. without leading “4” + check digit (X)



Rollbares Kunststoff-Koffer-System mit Trageinsatz

Die großvolumige, 2-teilige Werkzeugkoffer-Kombination mit integriertem Trolley für den preisbewussten Hobby-Handwerker mit Features eines Profi-Werkzeugkoffers. Die optimale Lösung für unterwegs.

Wheeled plastic case system with plastic case with removable carrying insert

Spacious two-part tool case with integrated trolley, an ideal combination for price-conscious DIY craftsmen wishing to enjoy the features of a professional tool case. The perfect mobile solution!



2 Sortimentskästen im Deckel

2 assortment boxes integrated in the lid



Mit aufgestelltem Griff als Trolley einsetzbar

Sturdy aluminium bracket latches



Stabile Verbindung von Ober- und Unterteil

Aluminium handle for safe carrying



Herausnehmbares Werkzeugtray

Cantilever design for optimum access to the items inside



Hervorragende Logistik durch nestbare Verpackung

Nestable packaging ensures excellent logistical benefits



1 McPlus Mobile >P< 24

476138(2)

465 x 265 x 620

400 x 190 x 170

1

5

EAN = 4005187 + Art. Nr. ohne führende „4“ + Prüfziffer (X) / EAN = 4005187 + Art. No. without leading “4” + check digit (X)

Kunststoff-Aufbewahrungskoffer

Transluzente bzw. farbige Helfer für viele Anwendungen im Haushalt, beim Hobby oder im Kinderzimmer.

Plastic storage case

Translucent or coloured assistants for many applications in the household, hobby area or in the children's playroom.



Herausnehmbare Trageschale
Removable carrying tray



Bithalter im herausnehmbaren Tragekasten
Bit holder in the removable tote tray



Mobiler Tragekasten zur Werkzeug- und Kleinteileaufbewahrung
Mobile carrying tray for the storage of tools and small parts



Auch auf verkaufsfördernder Aktionspalette.
Also on a promotional campaign range.



Maßeinteilung mit cm/inch
Ruler with cm/inch scale



Solider Einhandgriff
Solid single handle



mm



mm



	EAN	Color	Dimensions (mm)	Dimensions (mm)	Quantity	Quantity
1 McPlus Clear 12.5	416400(8)	Orange	310 x 170 x 130	265 x 130 x 60	6	60*
2 McPlus Clear 12.5	416401(5)	Blue	310 x 170 x 130	265 x 130 x 60	6	5
3 McPlus Clear 16	416411(4)	Red	400 x 220 x 200	345 x 150 x 95	4	5
4 McPlus Clear 16	416413(8)	Green	400 x 220 x 200	345 x 150 x 95	4	5

EAN = 4005187 + Art. Nr. ohne führende „4“ + Prüfziffer (X) / EAN = 4005187 + Art. No. without leading “4” + check digit (X)

*) Ab einer Bestellmenge von 1.000 Stück oder Rahmenvereinbarung. / *) For order quantities of 1,000 pcs general agreement.



Kunststoff-Profi-Werkzeug-Tragekasten

Alles im Griff! Der Werkzeug-Tragekasten mit vielen unterschiedlichen Werkzeugaufnahmen und Kleinteile-Sortierkästen ist der praktische, clevere Allrounder für Haushalt, Werkstatt, Hobby und Freizeit.

Professional-style plastic tool tote tray

Everything right at hand! This convenient carrier box is equipped with many different tool holders and organiser compartments for small parts – it is a smart all-rounder solution for household, workshop, DIY and leisure time.

Fächermaße / Compartment size



- 2x 365 x 65 x 90 mm
- 2x 120 x 65 x 240 mm
- 1x 115 x 65 x 110 mm



Alternative Version auf Anfrage
Alternate version upon request



4 herausnehmbare Sortimentskästen im Boden
4 lift-out organisers in the base

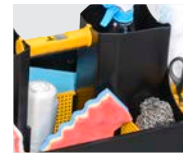

Einer für alles!
One for all!



Individuelle Einteilung durch arretierbare Trenstege
Plastic dividers can be locked in place to form customised compartments



Zahlreiche Werkzeugaufhalter
Numerous tool holders



Schieber schützt Sortimentskästen vor Herausfallen
Slider bar protects organisers from falling out



Stabiler, ergonomischer Handgriff
Sturdy, ergonomic handle



Fächermaße / Compartment size



- 1x 165 x 38 x 34 mm
- 4x 53 x 38 x 34 mm
- 1x 53 x 80 x 34 mm



mm



1 McPlus Workman 19/62

457285(8)



485 x 295 x 300

2

5

EAN = 4005187 + Art. Nr. ohne führende „4“ + Prüfziffer (X) / EAN = 4005187 + Art. No. without leading “4” + check digit (X)

Kunststoff-Mehrzweck-/ Zimmermanns-Tragekasten

Praktische Helfer für Werkstatt, Haushalt oder Freizeit. Ideal auch als preiswerter und ansprechender Werbeträger für Ihr Unternehmen mit individuellem Werbeaufdruck. McPlus Carry 40 ist beidseitig auf einer Fläche von 325 x 85 mm im Siebdruck bedruckbar.

Portable multi-purpose and carpenters tote trays

Practical helpers for workshop, household or leisure. Ideal also as inexpensive, yet attractive advertising media for your company available with customised promotional prints. McPlus Carry 40 totes can be screen printed (serigraphed) on both sides over an area of 325 x 85 mm.



1 Platz für Schraubendreher oder Bits
Space for screwdrivers or bits

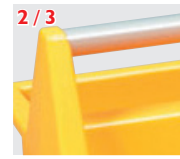

2/3 Bügelgriff aus Aluminium
Ergonomic bow-shaped aluminium handle



2/3 Lineal (cm/inch) an den Fächern
Scaling (cm/inch) on the compartments



2/3 Auch erweiterbar mit hohen Einsatzboxen (siehe S. 79)
Can also be expanded with tall insert boxes (see p. 79)



2/3 Einsatzboxen EuroPlus Insert als Zubehör erhältlich (siehe S. 78)
EuroPlus insert bins available as accessories (see p. 78)

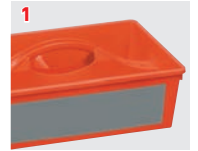

1 Druckfläche McPlus Carry 38: 1 x 325 x 85 mm, 2 x 130 x 88 mm
Printing area McPlus Carry 38: 1 x 325 x 85 mm, 2 x 130 x 88 mm



Mindestmenge: 250 St. (Standardfarbe), 1.000 St. (in individueller Farbgebung)
Minimum order quantity: 250 pcs (standard colour), 1,000 pcs (customised colours)



Der Profi-Tragekasten aus Kunststoff mit Verbindungsverschluss und Adapterfunktion (siehe S. 68)
The professional plastic carrying case with connection lock and adapter function (see p. 68)



1 McPlus Carry 38	457278(0)		380	x	250	x	145	340	x	80	x	114
2 McPlus Carry 40	457279(7)		395	x	290	x	215	325	x	98	x	110
3 McPlus Carry >P< 40	457280(3)		395	x	290	x	215	325	x	98	x	110

EAN = 4005187 + Art. Nr. ohne führende „4“ + Prüfziffer (X) / EAN = 4005187 + Art. No. without leading “4” + check digit (X)



Stahlblech / Sheet steel



Stahlblech-Werkzeugkästen

Klassische Werkzeugkästen mit ausziehbaren Fächern und gerundeten Kanten für Handwerk, Haushalt und Hobby.

Sheet steel tool boxes

Classic tool boxes with pull-out compartments and rounded edges for craft, the household and hobby.



Mit handelsüblichem Vorhängeschloss abschließbar
Lockable with a standard padlock



Pulverbeschichtet mit Hammerschlagoptik
Powder-coated with hammer-tone finish



Stabiler Doppelgriff
Sturdy double handle

Fächermaße / Compartment size



mm

1 490611

- 2x 200 x 95 x 45 mm
- 2x 200 x 95 x 45 mm
- 2x 200 x 95 x 45 mm
- 1x 200 x 95 x 45 mm

2 490612

- 2x 250 x 95 x 45 mm
- 1x 500 x 95 x 45 mm
- 1x 500 x 155 x 105 mm
- 2x 500 x 75 x 45 mm

3 490613

- 2x 250 x 95 x 45 mm
- 1x 500 x 95 x 45 mm
- 1x 500 x 155 x 105 mm
- 4x 500 x 75 x 45 mm



Selbsterklärend im Regal
Self-explaining on the shelf



	EAN	Icon	mm	Icon	Icon
1	McPlus Metall 5/47	490611(0)	450 x 220 x 220	1	5
2	McPlus Metall 5/57	490612(7)	560 x 220 x 220	1	5
3	McPlus Metall 7/57	490613(4)	560 x 220 x 265	1	5

EAN = 4005187 + Art. Nr. ohne führende „4“ + Prüfziffer (X) / EAN = 4005187 + Art. No. without leading “4” + check digit (X)

Textil Werkzeugtaschen mit stabilem Tragegriff

Hervorragende Helfer in robuster und leichter Textil-Stoff-Ausführung im attraktiven Design. Die Tasche bietet mit viel Stauraum und Haltevorrichtungen Ordnung am Arbeitsplatz.

Textile tool bags with a sturdy carrying handle

Excellent helpers in robust and lightweight textile fabric design in attractive design. The bag provides plenty of storage space and holding devices in the workplace.



Abnehmbarer Tragegurt
Removable carrying strap



Griff seitlich wegklappbar
The handle can be pushed to the side



Stabiler Kunststoffboden
Robust plastic base



Staubschutz im Lieferumfang enthalten
Protective dust cover included



mm



mm



1 McPlus Bag >C< 18-1

479120(4)



460 x 235 x 290

340 x 160 x 225

2

5

2 McPlus Bag >C< 20-1

479130(3)



520 x 290 x 370

385 x 180 x 260

2

5

EAN = 4005187 + Art. Nr. ohne führende „4“ + Prüzfiffer (X) / EAN = 4005187 + Art. No. without leading “4” + check digit (X)



AluPlus Basic »L« 35

(siehe S. 37 / see p. 37)



McPlus Clear

(siehe S. 48 / see p. 48)



McPlus Promo 20

(siehe S. 46 / see p. 46)

Betriebs-, Fahrzeug- und Lagereinrichtung mit innovativen Kleinteilekoffern aus Kunststoff und Metall inklusive der dafür notwendigen Einsatzboxen u.a. auch separat für Schubladen-, Schrank- und Regalsortierung einsetzbar.

Smart shop floor, vehicle and warehouse organisation solutions revolving around innovative small parts cases made of plastic and metal. The small parts cases of this range feature versatile insert bins that are sure to star in their own right when joining forces with drawers, cupboards, cabinets or shelving units.



EuroPlus Pro ›K‹

62



EuroPlus Roll it ›K‹

66



EuroPlus Pro ›KC‹ 44.150

68



EuroPlus HybridPlate

70



EuroPlus MetaBox

72



EuroPlus Depot ›M‹

74



EuroPlus Roll it ›M‹

75



EuroPlus Pro ›M‹

76



**EuroPlus Insert & Insert 130/3
EuroPlus Set 63 (Insert)**

78/79
80



EuroPlus Box ›D‹

81



EuroPlus Flex 37

82



**EuroPlus Basic ›S‹
EuroPlus Basic ›S‹ Sets**

84
85



EuroPlus Basic

87



EuroPlus Basic 29 & 37

88



EuroPlus Depot & Set 45

90



EuroPlus Duo 38 & Flex 42

91



Das Koffersystem EuroPlus

Für sichere Aufbewahrung und Transport von Werkzeug und Kleinteilen.



EuroPlus Pro ›K‹ 44.76
Profi-Kleinteilekoffer
Small-Parts Case



EuroPlus Roll it ›K‹ 110
Transportkarre
Transport trolley

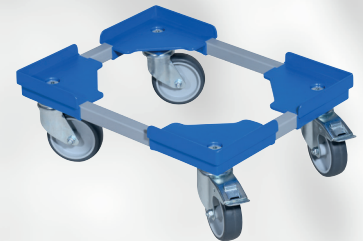

EuroPlus Roll it ›K‹ 450
Transportroller
Transport roller



EuroPlus Pro ›K‹ 44.144
Profi-Kleinteilekoffer
Small-Parts Case



EuroPlus Pro ›KC‹ 44.150
Profi-Tragekasten mit Adapterfunktion
Professional plastic carrying with adapter function

Bestehend aus:

EuroPlus Pro ›K‹, MetaBox,
 HybridPlate, Depot ›M‹ & Pro ›M‹



EuroPlus Hybrid Plate
Multi-Adapter Platte
Multi-adapter plate



The EuroPlus case system

For safe storage and transport of tools and small parts.

EuroPlus Depot ›M‹

Kofferschrank
Trunk cupboard



EuroPlus Roll it ›M‹ 596

Transportroller
Transport trolley



EuroPlus Pro ›M‹

Stahlblech-Metall-Kleinteilekoffer
Metal small-parts cases



EuroPlus MetaRoll

Rollbrett für
EuroPlus MetaBox
Roller board for
EuroPlus MetaBox



EuroPlus MetaBox 340

Transport- und Aufbewahrungsbox
Transport and storage box



Consists:

EuroPlus Pro ›K‹, MetaBox,
HybridPlate, Depot ›M‹ & Pro ›M‹



EuroPlus MetaBox 215

Transport- und Aufbewahrungsbox
Transport and storage box



EuroPlus MetaBox 118

Transport- und Aufbewahrungsbox
Transport and storage box



EuroPlus MetaBox 145

Transport- und Aufbewahrungsbox
Transport and storage box



MOBILITÄT / MOBILITY



EuroPlus Pro ›K‹ 44.76
(siehe S. 62 / see p. 62)



EuroPlus Insert ›L‹ 130/3
auch als Zubehör erhältlich
EuroPlus Insert ›L‹ 130/3
available as an equipment.

MOBILITÄT

Das komplette EuroPlus Pro ›K‹ System wird fahrbar gemacht dank passender Transportkarre wie auch passendem Transportroller. Schweres Heben und mehrmaliges Laufen gehören der Vergangenheit an (siehe S. 66/67).

MOBILITY

The complete EuroPlus Pro ›K‹ system is made mobile thanks to the right transport cart and transport roller. Heavy lifting and repeated running are a thing of the past (see p. 66/67).

AUFBEWAHRUNG / STORAGE



MOBILE AUFBEWAHRUNG

Platzierung im wie auch auf dem EuroPlus Depot ›M‹ möglich. Somit kann ein rollbarer Aufbewahrungsort für Kleinteilekoffer und andere Koffersysteme geschaffen werden (siehe S. 75).

MOBILE STORAGE

Placement in as well as on the EuroPlus Depot ›M‹ possible. In this way, a mobile storage location for small parts cases and other case systems can be created (see p. 75).



EuroPlus Pro ›M‹
(siehe S. 76 / see p. 76)



KOMPATIBEL

Durch den professionellen Tragekasten mit Adapterfunktion lassen sich die Kleinteilekoffer problemlos auch mit gängigen Koffersystemen anderer Hersteller verbinden (siehe S. 68).

COMPATIBLE

Thanks to the professional carrying case with adapter function, the small parts cases can also be easily connected to standard case systems from other manufacturers (see p. 68).

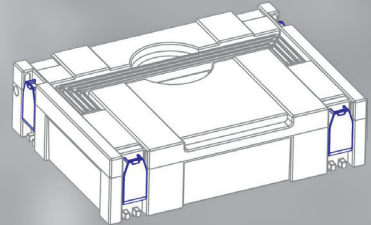
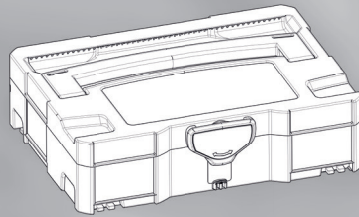

SYSTEMNEUTRAL

Durch die EuroPlus HybridPlate lässt sich das EuroPlus Pro »K« System, wie auch viele gängige Koffersysteme anderer Hersteller verbinden (siehe S. 70)

SYSTEM-NEUTRAL

The EuroPlus Pro »K« system can be connected with the EuroPlus HybridPlate, as can many common case systems from other manufacturers (see p. 70).



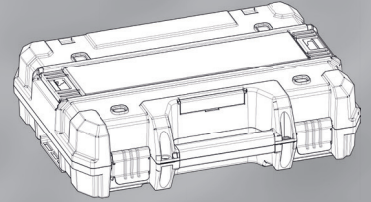
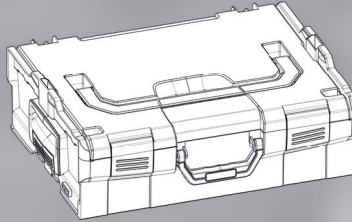

Die Kleinteilekoffer können mit den Aufbewahrungs- und Transportboxen EuroPlus MetaBoxen miteinander verbunden werden. Somit ist mehr Raum für Teile unterschiedlicher Art und Größe, kompakt zusammen an einem Ort (siehe S. 72).

The small parts cases can be connected to the storage and transport boxes EuroPlus MetaBoxes. This means there is more space for parts of different types and sizes, all in one place (see p. 72).



Kleinteilekoffer mit Verbindungsclips und hochschlagfestem Deckel

Der hochschlagfeste Polycarbonat-Deckel auf dem soliden Unterteil sorgt für eine sichere Unterbringung von Kleinteilen. Durch die entnehmbaren Einsatzboxen und/oder Trennsteg ist der Koffer individuell anpassbar. Der Transport mehrerer Koffer ist mithilfe der Verbindungsverschlüsse schnell und einfach möglich.

Small parts cases with connection clips and high-impact lid

The highly impact-resistant polycarbonate lid on the solid base ensures that small parts are safely stored. The case can be individually adjusted thanks to the removable insert boxes and/or dividers. The transport clips make it possible to transport several cases quickly and easily.



Dicht schließender Polycarbonat-Deckel
Tightly fitting polycarbonate lid



Einsatzboxen u.a. mit Trennsteg
Insert bins, e.g. equipped with dividers



Entnehmbare Einsatzboxen
Removable insert boxes



Passend zu EuroPlus Depot ›M‹ (siehe S. 74)
Compatible with EuroPlus Depot ›M‹ (see p. 74)



Verbindungsverschluss ermöglicht Transport in Verbund bis zu 36 kg
Connection clips enables transport in a group up to 36 kg



Innovativer Verbindungsclip
Innovative connectionclip

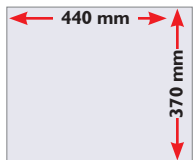

Passend zu Standard-Bodenmaß

Suitable for Standard ground dimensions



Transluzente Einsatzboxen auf Anfrage
Translucent insert boxes on request



EuroPlus Insert S. 78
EuroPlus Insert p. 78



mm



mm



	EAN	Icon	Dimensions (mm)	Dimensions (mm)	Boxes	Trucks
1 EuroPlus Pro ›K‹44.76/7	454200(4)	Black	440 x 355 x 76	400 x 275 x 60	1	5
2 EuroPlus Pro ›K‹44.76/23	454210(3)	Black/Green	440 x 355 x 76	400 x 275 x 60	1	5
3 EuroPlus Pro ›K‹44.76/15	454220(2)	Black/Blue	440 x 355 x 76	400 x 275 x 60	1	5
4 EuroPlus Pro ›K‹44.76/19	454222(6)	Black/Orange	440 x 355 x 76	400 x 275 x 60	4	5
5 EuroPlus Pro ›K‹44.76/19	454223(2)	Black/White	440 x 355 x 76	400 x 275 x 60	1	5
6 EuroPlus Pro ›K‹44.76/18	454230(1)	Black/Green	440 x 355 x 76	400 x 275 x 60	1	5
7 EuroPlus Pro ›K‹44.76/21	454240(0)	Black/Orange	440 x 355 x 76	400 x 275 x 60	1	5
8 EuroPlus Pro ›K‹44.76/36	454250(9)	Black/Red	440 x 355 x 76	400 x 275 x 60	1	5
9 EuroPlus Pro ›K‹44.76/8-6	454260(8)	Black	440 x 355 x 76	400 x 275 x 60	1	a.A.*
10 EuroPlus Pro ›K‹44.76/12-6	454270(7)	Black/Orange	440 x 355 x 76	400 x 275 x 60	1	5
11 EuroPlus Divider ›K‹44.76	454265(3)	Black	150 x 40 x 320	-	1	5

EAN = 4005187 + Art. Nr. ohne führende „4“ + Prüfziffer (X) / EAN = 4005187 + Art. No. without leading “4” + check digit (X)

* a. A. = Auf Anfrage / Upon Request



Polycarbonat / Polycarbonate



Im attraktiven Verkaufskarton
In attractive retail box

Transluzente Einsatzboxen auf Anfrage
Translucent insert boxes on request



Passend für jeden EuroPlus Pro ›K‹ 44.76
Suitable for every EuroPlus Pro ›K‹ 44.76

Innovativer Profi-Kleinteilekoffer mit Clips aus Kunststoff

Der hochschlagfeste Polycarbonat-Deckel auf einem soliden Unterteil erlaubt eine sichere Unterbringung von Kleinteilen. Die Koffer können mit Einsatzboxen individualisiert und durch einen Verbindungsverschluss sicher verbunden und gestapelt werden. Somit ist der sichere Transport mehrerer Profi-Kleinteilekoffer schnell und einfach möglich.

Innovative professional small parts case made of plastic with connection closure

The high-impact polycarbonate lid on a solid base allows secure storage of small parts. The cases can be customized with insert boxes and securely connected by a connection closure. This means that several professional small parts cases can be transported quickly and easily.



Dicht schließender Polycarbonat-Deckel
Tightly fitting polycarbonate lid



Entnehmbare Einsatzboxen
Removable insert boxes



Innovativer Verbindungsverschluss ermöglicht eine sichere Verriegelung

Expandable with other EuroPlus Pro Innovative connection lock enables secure locking

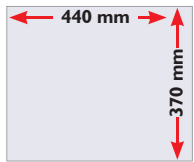

Passend zu Standard-Bodenmaß
Suitable for Standard ground dimensions



Passend zu EuroPlus Depot >M< (siehe S. 74)
Compatible with EuroPlus Depot >M< (see p. 74)



EuroPlus Insert S. 79
EuroPlus Insert p. 79



	EAN	Icon	mm	mm	Icon	Icon
1 EuroPlus Pro >K< 44.144/1	454300(1)		440 x 355 x 144	400 x 290 x 126	1	5
2 EuroPlus Pro >K< 44.144/8L	454310(0)		440 x 355 x 144	400 x 290 x 126	1	5
3 EuroPlus Pro >K< 44.144/8	454322(3)		440 x 355 x 144	400 x 290 x 126	2	5

EAN = 4005187 + Art. Nr. ohne führende „4“ + Prüzfiffer (X) / EAN = 4005187 + Art. No. without leading “4” + check digit (X)



Polycarbonat / Polycarbonate



1

Kann mit Einsatzboxen individuell bestückt werden (siehe S. 79)

Can be fitted individually with insert boxes (see p. 79)



2



3



Im attraktiven Verkaufskarton
In attractive retail box

Profi-Transportkarre für EuroPlus Pro ›K‹ und andere Lasten

Wendig, unkompliziert, funktionell und belastbar – Die Transportkarre sorgt für höchste Mobilität in Werkstatt und Betrieb. Das EuroPlus Pro ›K‹ System und viele weitere Boxen und Lasten lassen sich somit problemlos und sicher transportieren. Der stufenlose, verstellbare Spanngurt sorgt für weitere Sicherheit beim Transport.

Professional transport trolley for EuroPlus Pro ›K‹ and other loads

Manoeuvrable, uncomplicated, functional and resilient - The Transport trolley ensures maximum mobility in the workshop and Operation. The EuroPlus Pro ›K‹ system and many other boxes and loads can be therefore easy and safe to transport. The stepless, adjustable strap ensures additional safety during transport.



Transport von unterschiedlichsten Koffern und Boxen.
Transport of a wide variety of suitcases and boxes.

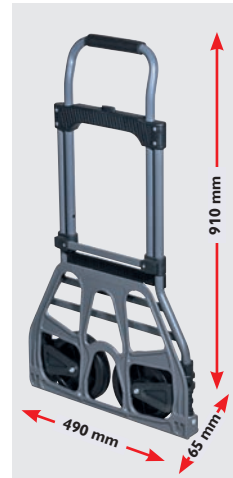

Leicht zu Transportieren und zu Verstauen
Easy to transport and store



Stufenlos höhenverstellbarer Spanngurt für zusätzliche Sicherung
Infinitely height-adjustable tensioning belt for additional security



Ausziehbarer ergonomischer Teleskopgriff
Extendable ergonomic telescopic handle



1



Tragkraft bis zu max. 130 kg bei gleichmäßiger Beladung.
Load capacity up to max. 130 kg with even loading.



mm



mm



1 EuroPlus Roll it ›K‹ 110

454380(3)

490 x 520 x 1100

485 x 300 x 1100

1

5

EAN = 4005187 + Art. Nr. ohne führende „4“ + Prüzfiffer (X) / EAN = 4005187 + Art. No. without leading “4” + check digit (X)



ABS-Kunststoff, Aluminium / ABS-plastic, Aluminium



Profi-Transportroller für EuroPlus Pro >K< 44

Durch sein zugeschnittenes, kompaktes Format für EuroPlus Pro >K< 44 und einer hohen Tragkraft, ist der professionelle Transportroller das ideale Transportmittel für Kleinteilekoffer innerhalb der Werkstatt, Betrieb und Lager. Mit kugelgelagerten Lenkrollen und zwei Feststellbremsen lässt sich der Roller in alle Richtungen bewegen, somit wird die Mobilität einfach, schnell und unkompliziert. Die hellgrauen, leise laufenden Gummiräder sind mit verzinktem Stahl/rostfreiem Edelstahl befestigt. Stabile Kunststoffecken mit hohem Rand dienen als Abrutschsicherung.

Professional transport roller for EuroPlus Pro >K< 44

Due to its tailored, compact format for EuroPlus Pro >K< 44 and a high load capacity, the professional transport roller is the ideal means of transport for small parts cases within the workshop, factory and warehouse. With ball-bearing castors and two parking brakes, the scooter can be moved in all directions, making mobility easy, quick and uncomplicated. The light gray, quiet-running rubber wheels are galvanized Steel/stainless steel attached. Sturdy plastic corners with a high edge serve as slip protection.



Auch für andere Gegenstände geeignet
Also suitable for other items



Zugeschnittenes, kompaktes Format für EuroPlus Pro >K< 44
Tailored, compact format for EuroPlus Pro >K< 44



Lenkrolle
Swivel castor



Bremsrolle
Braked castor



Tragkraft bis zu max. 300 kg bei gleichmäßiger Beladung.
Load capacity up to max. 300 kg with even loading.



1



mm



mm



1 EuroPlus Roll it >K< 450

454385(8)

455 x 355 x 175

445 x 345 x 20

1

5

EAN = 4005187 + Art. Nr. ohne führende „4“ + Prüfziffer (X) / EAN = 4005187 + Art. No. without leading “4” + check digit (X)

Profi-Tragekasten aus Kunststoff mit Verbindungsverschluss und Adapterfunktion

Universeller Helfer mit Adapterfunktion zum Aufbewahren und Transportieren für Werkstatt, Lager und Betrieb. Der Profi-Tragekasten kann mit Einsatzboxen individualisiert und durch Verbindungsverschlüsse sicher mit EuroPlus Pro ›K‹ 44 und anderen Koffersystemen verbunden werden.

Professional plastic carrying case with connection lock and adapter function

Universal helper with adapter function for storage and transport for workshop, warehouse and company. The professional plastic carrying case can be customized with insert boxes and securely connected to EuroPlus Pro ›K‹ 44 and other case systems using connecting locks.



Verklickbar mit allen EuroPlus Pro ›K‹ 44 Profi-Kleinteilekoffern
Clickable with all EuroPlus Pro ›K‹ 44 professional small parts cases



Erweiterbar mit herausnehmbaren Einsatzboxen inkl. Deckel
Expandable with removable insert boxes incl. lid



Transport im Verbund bis max. 36 kg
Transport in combination up to a maximum of 36 kg



Im Verbund auch als Profi-Kleinteilekoffer nutzbar
Can also be used as a professional small parts cases in combination



1



2



1 EuroPlus Pro ›KC‹44.150/2L

2 EuroPlus Pro ›KC‹44.150

454360(5)

440 x 355 x 150

2

5

454365(0)

440 x 355 x 150

1

5

EAN = 4005187 + Art. Nr. ohne führende „4“ + Prüzfiffer (X) / EAN = 4005187 + Art. No. without leading “4” + check digit (X)



Adapterfunktion zur Verbindung unterschiedlichster Koffersysteme

Mit der innovativen Adapterfunktion des Profi-Tragekastens ist es möglich EuroPlus Pro ›K‹ 44 Profi-Kleinteilekoffer mit unterschiedlichen Koffersystemen zu verbinden und damit sicher zu stapeln.

Adapter function for connecting different case systems

With the innovative adapter function of the professional carrying case, it is possible to connect the EuroPlus Pro ›K‹ 44 professional small parts case to different case systems and thus stack them safely.



Innovativer Verbindungsclip für EuroPlus Pro ›K‹ 44 Kleinteilekoffer

Innovative connection clip for EuroPlus Pro ›K‹ 44 small parts case



Graue Systemadapter ermöglichen Verbindung zu weiteren Koffersystemen

Gray system adapters enable connection to other case systems

Passend für EuroPlus Pro ›K‹ Kleinteilekoffer Suitable for the EuroPlus Pro ›K‹ small parts case



Passend für EuroPlus HybridPlate Suitable for EuroPlus MetaBoxes



Durch Adapter-Platte Verbindung zu EuroPlus MetaBoxen möglich (siehe S. 71)

Connection to EuroPlus MetaBoxes possible with adapter plate (see p. 71)



Passend für weitere gängige Koffersysteme / Suitable for more common case systems

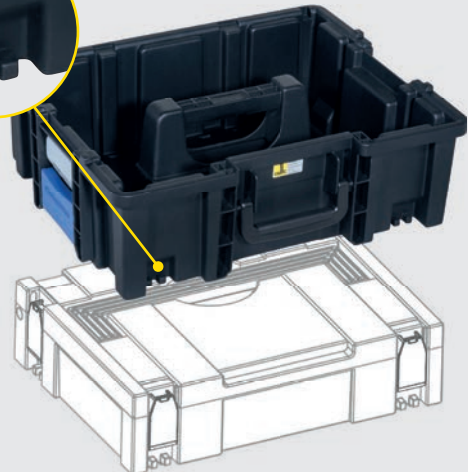
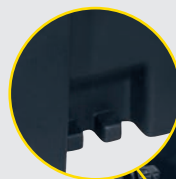
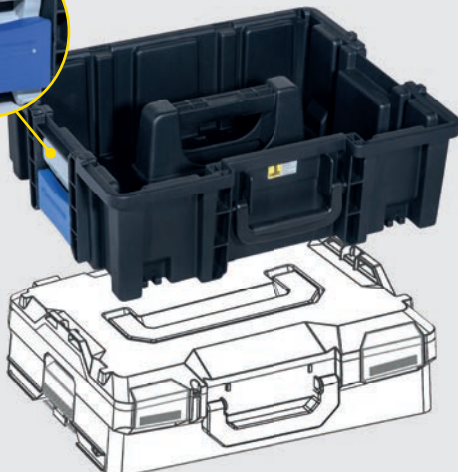

Die Multi Hybrid Adapter Platte

Die vielseitige multifunktionale Adapter Platte aus stabilem ABS Kunststoff ist ein wahrer Alleskönner auf dem Gebiet der Adaption. Durch die Hybrid Platte ist es möglich EuroPlus MetaBoxen mit dem EuroPlus Pro »K« System sowie auch weiteren, gängigen Koffersystemen schnell und unkompliziert zu verbinden. Die einfachen Kopplungssysteme ermöglichen ein Verklicken in wenigen Sekunden und sorgen somit für viele denkbare unterschiedliche Kombinationsmöglichkeiten. Sie kann zusätzlich an vielen nützlichen Orten verschraubt werden, um so einen individuellen Aufbewahrungsort für die jeweiligen Koffersysteme zu bilden.

The Multi Hybrid Adapter Plate

The versatile, multifunctional adapter plate made of stable ABS plastic is a true all-rounder in the field of adaptation. Thanks to the hybrid plate, it is possible to use EuroPlus MetaBoxes with the EuroPlus Pro »K« system as well to connect other common case systems quickly and easily. The simple coupling systems enable a click in a few seconds and thus ensure many conceivable different possible combinations. It can also be screwed in many useful places to create an individual Storage location for the respective case systems.

**Verklickbar mit EuroPlus Pro »K«
und gängigen Systemboxen anderer Hersteller**
Can be clicked with EuroPlus Pro »K«
and common system boxes other manufacturers

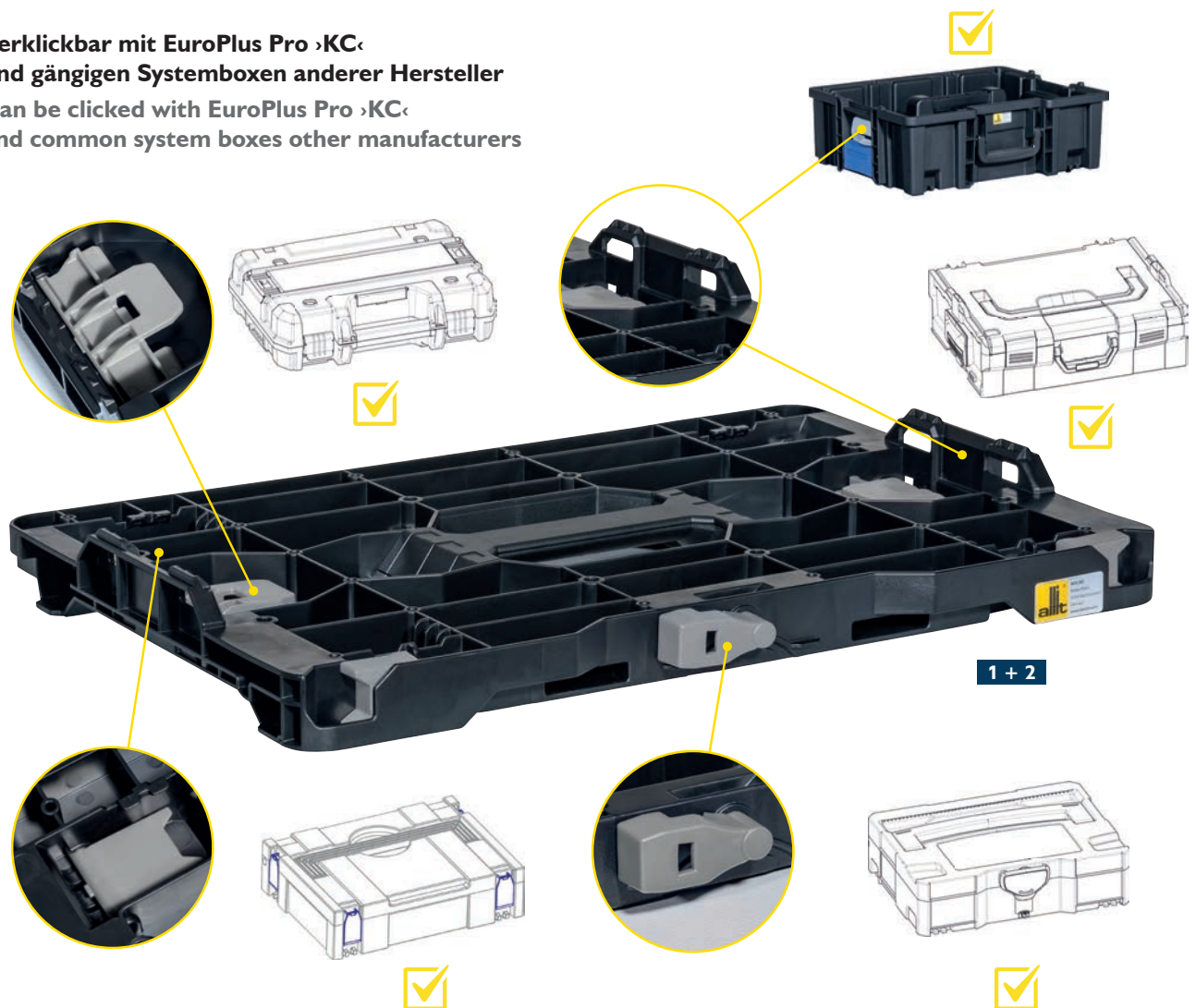

mm



1	EuroPlus HybridPlate	454490(4)		445 x 300 x 55	5	5
2	EuroPlus HybridPlate	454491(6)		445 x 300 x 55	1	5

EAN = 4005187 + Art. Nr. ohne führende „4“ + Prüfziffer (X) / EAN = 4005187 + Art. No. without leading “4” + check digit (X)



ABS Kunststoff / ABS-plastic



Anbringung eines weiteren Koffersystemes / Attachment of another case system

Schritt 1 / Step 1



Die Adapter Platte wird mit der glatten Seite auf die MetaBox gelegt und mit dessen Drehverschluss sicher fixiert.

The adapter plate comes with the flat side on the MetaBox and securely fastened with its screw cap.

Schritt 2 / Step 2



Nun können Sie den Profi-Tragekasten EuroPlus Pro ›KC‹ auf die Adapter Platte setzen und die dafür vorgesehene Adapterfunktion betätigen (siehe S. 69).

You can now place the professional carry case EuroPlus Pro ›KC‹ on the adapter plate and activate the adapter function provided (see p. 69).

Schritt 3 / Step 3



Sie können nun weitere Profi-Kleinteilekoffer EuroPlus Pro ›K‹ stapeln. Alle Systeme sind fest miteinander verbunden. Die MetaBoxen lassen sich weiterhin problemlos im Verbund öffnen.

You can now stack other professional small parts cases EuroPlus Pro ›K‹. All systems are firmly connected to each other. The MetaBoxes can still be opened together without any problems.

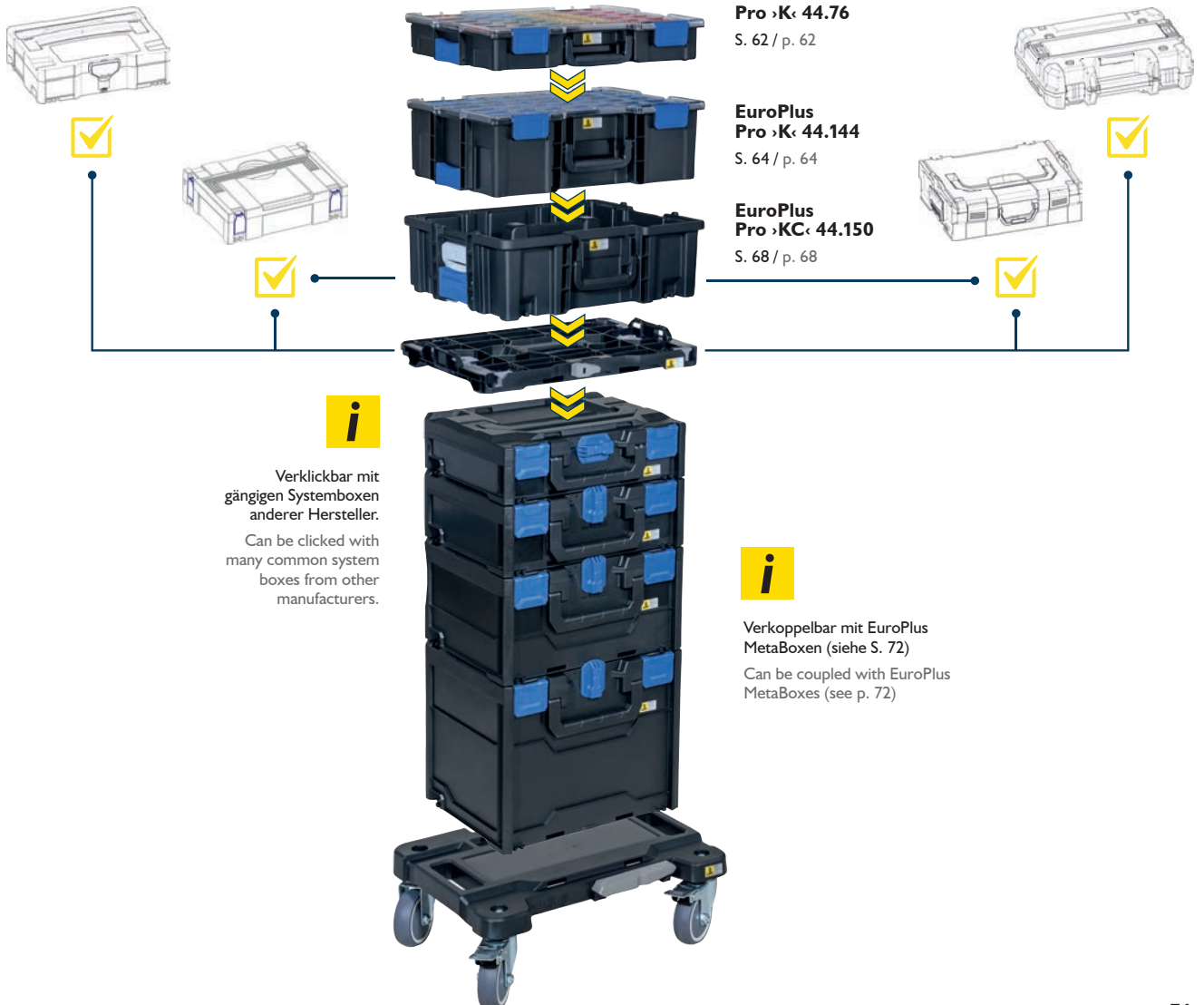

Professionelle Transport- und Aufbewahrungsboxen mit Kopplungssystem

Die bruchfesten Transport- und Aufbewahrungsboxen aus hochwertigem ABS bieten optimalen Schutz gem. Schutzklasse IP43 für Maschinen, Werkzeug und Zubehör sowie viele weitere Teile. Durch das einfache Stapeln und problemlose Öffnen im Verbund, ist es möglich jede Box zu öffnen, ohne andere entfernen zu müssen. Durch das kinderleichte Koppeln/Endkoppeln wird das Arbeiten noch flexibler und anwenderfreundlicher. In Kombination mit dem mobilen Rollwagen EuroPlus MetaRoll, können alle Aufbewahrungsboxen unkompliziert und sicher transportiert werden.

Professional transport and storage boxes with coupling system

The unbreakable transport and storage boxes made of high-quality ABS offer optimal protection according to protection class IP43 for machines, tools and accessories as well as many other parts. Due to the simple stacking and without problems to opening in the group, it is possible to open each box without having to remove others. Due to the very easy coupling / decoupling, the work is still more flexible and user-friendly. In combination with the mobile trolley EuroPlus MetaRoll, all storage boxes can be transported easily and safely.



Im Stapel zu öffnen
Open in stack



Sicheres Kopplungssystem
Secure coupling system



Inklusive Trennsteg
Including dividers



Kompatibel zu EuroPlus Pro :K: und weiteren Koffersystemen (siehe S. 62)
Compatible with EuroPlus Pro :K: and other case systems (see p. 62)



i Alle Ebenen im Verbund zu öffnen.
Open all levels in the compound.



ABS-Kunststoff / ABS-plastic



1

EuroPlus MetaBox mini 63

- Platzsparende Box, als Kleinteilekoffer oder Brotdose nutzbar
- Inklusive praktischer Trennstege, 6 Fächer
- Space-saving box, can be used as a small parts case or lunch box
- Including practical dividers, 6 compartments



2

EuroPlus MetaBox 118

- Praktische Aufbewahrungsbox für Kleinteile.
- Max. Traglast Deckel: 125 kg
- Practical storage box for small parts
- Max. load capacity lid: 125 kg



3

EuroPlus MetaBox 145

- Ideale Aufbewahrungsbox z.B. für Akkuschrauber und Werkzeug
- Max. Traglast Deckel: 125 kg
- Ideal storage box e.g. for cordless screwdriver and tools
- Max. load capacity lid: 125 kg



4

EuroPlus MetaBox mini 215

- Optimale Größe für sperrige Teile und Werkzeuge
- Max. Traglast Deckel: 125 kg
- Optimal size for bulky parts and tools
- Max. load capacity lid: 125 kg



5

EuroPlus MetaBox 340

- Extra hohe Aufbewahrungsbox z. B. für Handkreissägen, Bauschaum, Kartuschen uvm.
- Max. Traglast Deckel: 125 kg
- Extra high storage box e.g. for hand-held circular saws, construction foam, cartridges and much more.
- Max. load capacity lid: 125 kg



6

EuroPlus MetaRoll

- Mobiler Rollwagen zum Verkoppeln von EuroPlus MetaBoxen mit Fußbedienung
- Mobile trolley for connecting EuroPlus MetaBoxes with foot control















EuroPlus HybridPlate

- Passend für alle EuroPlus MetaBoxen
- Adapter Platter ermöglicht Kombination aus EuroPlus MetaBoxen und EuroPlus Pro »K« sowie vielen anderen Koffersystemen
- Suitable for all EuroPlus MetaBoxes
- Adapter Platter enables combination of EuroPlus MetaBoxes and EuroPlus Pro »K« as well as many other case systems



EuroPlus HybridPlate (siehe S. 70)
EuroPlus HybridPlate, (see p 70)

			 mm	 mm		
1 EuroPlus MetaBox mini 63	454400(8)		250 x 167 x 63	230 x 125 x 42	10	5
2 EuroPlus MetaBox 118	454410(7)		396 x 296 x 118	360 x 265 x 80	1	5
3 EuroPlus MetaBox 145	454420(6)		396 x 296 x 145	360 x 265 x 110	1	5
4 EuroPlus MetaBox 215	454430(5)		396 x 296 x 215	360 x 265 x 180	1	5
5 EuroPlus MetaBox 340	454440(4)		396 x 296 x 340	360 x 265 x 305	1	5
6 EuroPlus MetaRoll	454495(4)		500 x 370 x 170	-	1	5

EAN = 4005187 + Art. Nr. ohne führende „4“ + Prüfziffer (X) / EAN = 4005187 + Art. No. without leading “4” + check digit (X)

Professionelle Unterbringung von Kleinteilekoffer EuroPlus Pro ›K‹ und EuroPlus Pro ›M‹

Der stabile 4-fach Kofferschrank garantiert eine schnelle und übersichtliche Verfügbarkeit Ihrer Kleinteilekoffer am Arbeitsplatz. Er verfügt über eine hohe Stabilität für tägliche Beanspruchung und Belastung im regelmäßigen Gebrauch. Er eignet sich zur Anbringung an der Wand, freistehend oder ist stapelbar. Das EuroPlus Depot ›M‹ lässt sich individuell anpassen durch ausbaufähige Schubladen. Dies ermöglicht eine flexible Unterbringung von Kleinteilekoffern mit einer maximalen Höhe von 150 mm.

Professional-style accommodation of small parts cases EuroPlus Pro ›K‹ and EuroPlus Pro ›M‹

This sturdy, four-level chest case places your small parts cases at your fingertips whenever you need them. The organiser tower is designed for everyday use and features excellent mechanical and dimensional stability. It can be attached to the wall, it can be used as a free-standing element, and it can be stacked. The EuroPlus Depot ›M‹ can be individually adapted using expandable drawers. This enables the flexible storage of small parts cases with a maximum height of 150 mm.



Schubladen-Einzelverriegelung verhindert selbstständiges Öffnen

Individual drawer locking prevents accidental opening



Schubladen können ausgebaut und individuell angepasst werden.

Drawers can be expanded and individually adjusted.

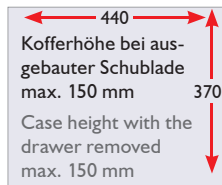

Tableaumaße der Auszüge
Tableaudimension of the drawers

1



Beispiel Unterbringung Examples of accommodation



Sonderfarben, Siebdrucke, Aufkleber auf Anfrage möglich.

Durch das Anbringen von der Adapter Platte und dem EuroPlus Pro ›KC‹ lassen sich EuroPlus Pro ›K‹ Kleinteilekoffer zur weiteren Aufbewahrung auf dem Depot platzieren. Dies schafft eine weitere Möglichkeit der individuellen Unterbringung.

Special colours (spot colours), silk-screen printing, adhesive labels upon request

By attaching the adapter plate and the EuroPlus Pro ›KC‹, the EuroPlus Pro ›K‹ small parts case can be placed on the depot for further storage. This creates another option for individual storage.



1 EuroPlus Depot ›M‹

455805(0)

505 x 380 x 465

1

5

EAN = 4005187 + Art. Nr. ohne führende „4“ + Prüfziffer (X) / EAN = 4005187 + Art. No. without leading “4” + check digit (X)



Stahlblech / Sheet steel



Professioneller Transportroller aus Metall für EuroPlus Depot >M<

Der robuste Transportroller mit einer Tragkraft bis 300 kg sorgt für höchste Mobilität in Werkstatt und Betrieb. Durch die hervorragenden Fahreigenschaften lassen sich gleich mehrere EuroPlus Depot >M< einfach und sicher befördern für eine schnelle übersichtliche Verfügbarkeit von Kleinteilen.

Professional metal transport trolley for EuroPlus Depot >M<

The robust transport roller with a load capacity of up to 300 kg ensures maximum mobility in the workshop and company. Due to the excellent driving characteristics, several EuroPlus Depot >M< can be transported easily and safely for a quick and clear availability of small parts.



4 kugelgelagerte Rollen davon 2 Lenkrollen mit Feststellbremsen sorgen für einfaches Handling beim Fahren

4 ball-bearing castors, 2 of which are swivel castors with parking brakes, ensure easy handling when driving



Mittels Adapter Platte lassen sich auch die MetaBoxen aufeinander stapeln

The MetaBoxes can also be stacked on top of each other using the adapter plate

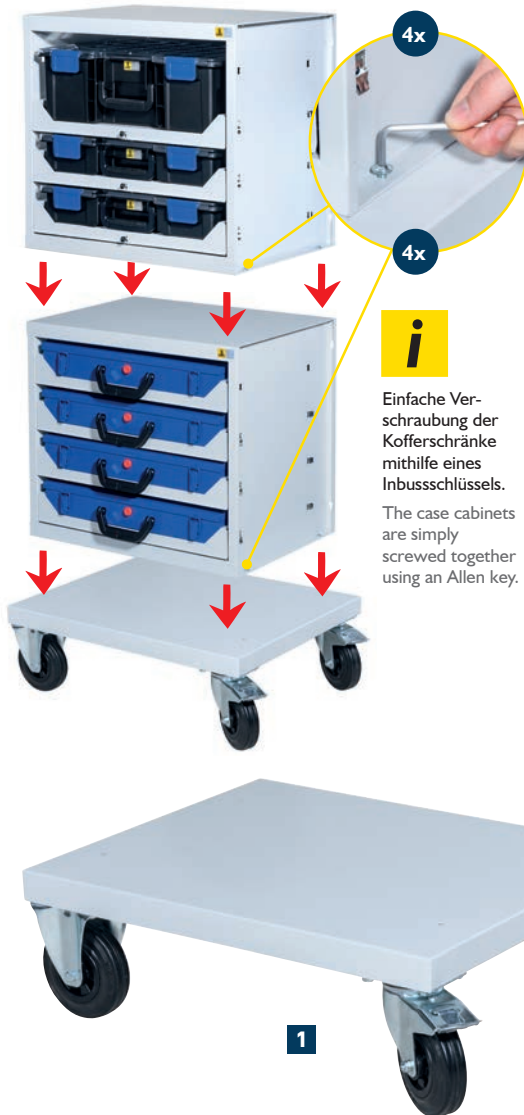

4x

4x



Einfache Verschraubung der Kofferschränke mithilfe eines Inbusschlüssels.

The case cabinets are simply screwed together using an Allen key.



4x



Bohrschablone als Download verfügbar.
Drilling template available for download.



Tragkraft bis zu max. 300 kg bei gleichmäßiger Beladung.
Load capacity up to max. 300 kg with even loading.



mm



1 EuroPlus Roll it >M< 596

455808(1)

595 x 475 x 195

1

5

EAN = 4005187 + Art. Nr. ohne führende „4“ + Prüfziffer (X) / EAN = 4005187 + Art. No. without leading “4” + check digit (X)

Artikel wird unbestückt und ohne seitliche Befestigungswände geliefert / Item is delivered empty and without side mounting walls

Stahlblech-Metall-Kleinteilekoffer mit herausnehmbaren Einsatzboxen

Stabile Kleinteilekoffer aus pulverbeschichtetem Stahlblech in dunkelblau mit ergonomischen Kunststoffgriff für den sicheren und geschützten Transport von Kleinteilen und Zubehör. In fünf Größen und acht Bestückungsvarianten oder als individuell bestückbarer Leerkoffer erhältlich.

Metal small parts cases with removable insert bins

Sturdy small parts cases made of sheet steel with dark-blue powder coat finish, equipped with an ergonomic plastic handle and designed for the safe and protected transport of small parts and accessories. Available in five sizes and eight configuration options, or as empty cases for customised organisation.



5 verschiedene Koffergrößen
5 different cases dimensions

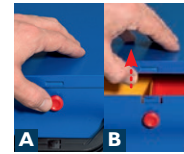

Zusätzliche Deckelsicherung
Additional lid lock

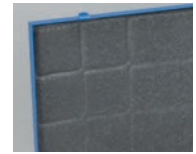

Schaumstoff im Deckel schließt fest mit Einsätzen ab
Foam in the lid locks firmly with inserts



Passend zu EuroPlus Depot >M< (siehe S. 74)
Compatible with EuroPlus Depot >M< (see p. 74)



Entnehmbare Einsatzboxen
Removable insert boxes



Erweiterbar mit EuroPlus Insert (siehe S. 78)
Extendable with EuroPlus Insert (see p. 78)

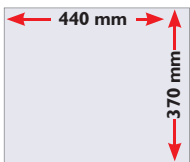

Passend zu Standard-Bodenmaß
Suitable for Standard ground dimensions



EuroPlus Insert (siehe S. 78-79)
EuroPlus Insert (see p. 78-79)



1	EuroPlus Pro >M< 44H-23	454120(5)	440 x 370 x 70	430 x 325 x 63	1	5
2	EuroPlus Pro >M< 44H-12	454121(2)	440 x 370 x 70	430 x 325 x 63	1	5
3	EuroPlus Pro >M< 44H-24	454122(9)	440 x 370 x 70	430 x 325 x 63	1	5
4	EuroPlus Pro >M< 44H-48	454123(6)	440 x 370 x 70	430 x 325 x 63	1	5
5	EuroPlus Pro >M< 44/2L-59	454124(3)	440 x 370 x 105	430 x 325 x 96	1	5

EAN = 4005187 + Art. Nr. ohne führende „4“ + Prüzfiffer (X) / EAN = 4005187 + Art. No. without leading “4” + check digit (X)



Pulverbeschichtetes Stahlblech, Polyamid 6 / Powder-coated sheet steel, Polyamide 6



1



2



3



4



5



6 7



8



9



10



11

EuroPlus Insert
(siehe S. 78-79)
EuroPlus Insert
(see p. 78-79)



12



6	EuroPlus Pro >M< 44H-1	454125(0)		440 x 370 x 70	430 x 325 x 63	1	5
7	EuroPlus Pro >M< 44L-1*	454129(8)		440 x 370 x 65	430 x 325 x 47	160**	5
8	EuroPlus Pro >M< 44L-23	454128(1)		440 x 370 x 65	430 x 325 x 45	2	5
9	EuroPlus Pro >M< 34L-14	454127(4)		335 x 250 x 65	325 x 215 x 45	5	5
10	EuroPlus Pro >M< 34H-1*	454130(4)		335 x 250 x 65	325 x 215 x 45	315**	5
11	EuroPlus Pro >M< 44XH-12L	454131(1)		440 x 370 x 135	430 x 325 x 130	1	5
12	EuroPlus Metall 34/18	454118(2)		335 x 250 x 53	330 x 230 x 49	1	5

EAN = 4005187 + Art. Nr. ohne führende „4“ + Prüfziffer (X) / EAN = 4005187 + Art. No. without leading “4” + check digit (X)

* keine Barcode-Auszeichnung / contains no barcode | ** VE pro Palette / PU per palette

Kunststoff-Einsatzboxen für Sortimentskästen, Mehrzwecktragekasten und Kleinteilekoffer

Die Einsatzboxen aus hochschlagfestem PS und PP bieten eine individuelle Einteilung für viele Artikel. Auch der Einsatz in Schubladen (Küche, Werkstatt, Büro ...) und Regalen ist problemlos denkbar. Sie erfüllen die Industriennorm für Schubladen- und Schranksysteme.

Plastic insert bins for assortment boxes, multipurpose boxes, tote trays and small parts cases

The insert bins made of high-impact PS offer an individual classification for many articles. The use in drawers (kitchen, workshop, office ...) and shelves is easily conceivable. They meet the industry standard for drawer and cabinet systems.



EuroPlus Pro -K: 44.76 (siehe S. 62)
EuroPlus Pro -K: 44.76 (see p. 62)



McPlus Carry 40 (siehe S. 50)
McPlus Carry 40 (see p. 50)



EuroPlus Flex 37 (siehe S. 82)
EuroPlus Flex 37 (see p. 82)



EuroPlus Pro -M: (siehe S. 76)
EuroPlus Pro -M: (see p. 76)



Kleine VE's im Cutcase
Small PU's in Cutcase



Praktisch Einsätze für Schrank, Schublade oder Regal
Inserts for cabinet drawer or shelf

	1		2		3		4		5	
	EuroPlus Insert 1		EuroPlus Insert 2		EuroPlus Insert 3		EuroPlus Insert 4		EuroPlus Insert 5	
Außenmaße (B x T x H) / Outside dim. (W x D x H) mm	54 x 54 x 45/63		54 x 108 x 45/63		108 x 108 x 45/63		108 x 162 x 45/63		108 x 216 x 45/63	
Nutzmaße (B x T x H) / Usable dimensions (W x D x H) mm	48 x 48 x 42/60		48 x 101 x 42/60		101 x 101 x 42/60		101 x 155 x 42/60		101 x 209 x 42/60	
Farbe / Colour										
VE/VE Industrie - 45 mm Stück	224	1.260*	112	630*	56	315*	35	207*	28	153*
PU/PU Industrie - 45 mm pcs										
Art.-Nr. (EAN) / Art. No. (EAN)	456300(9)	456310(8)	456301(6)	456311(5)	456302(3)	456312(2)	456303(0)	456313(9)	456304(7)	456314(6)
VE/VE Industrie - 63 mm Stück	160	980*	80	490*	40	245*	25	161*	20	119*
PU/PU Industrie - 63 mm pcs										
Art.-Nr. (EAN) / Art. No. (EAN)	456305(4)	456315(3)	456306(1)	456316(6)	456307(8)	456317(7)	456308(5)	456318(4)	456309(2)	456319(1)
Lieferzeit / Delivery Time Tage / days	5	5	5	5	5	5	5	5	5	5

EAN = 4005187 + Art. Nr. ohne führende „4“ + Prüfziffer (X) / EAN = 4005187 + Art. No. without leading “4” + check digit (X)

* keine Barcode-Auszeichnung / contains no barcode



Hohe Kunststoff-Einsatzboxen mit Staubdeckel für Sortimentskästen, Mehrzwecktragekasten und Kleinteilekoffer

Universell und praktisch! Die vielseitigen Einsatzboxen aus hochschlagfestem PP bieten universellen Einsatz für viele Artikel. Auch der Einsatz in Werkstatt, Küche, Schrank, Büro und Regalen ist problemlos möglich. Die Einsatzbox für Aufbewahrung hat einen Staubdeckel, der vor äußeren Einflüssen schützt. Eine kleine Box für große Aufgaben!

Tall plastic insert boxes with dust cover for assortment boxes, multi-purpose carrying boxes and small parts cases

Universal and practical! The versatile insert boxes made of high-impact PP offer universal use for many items. It can be used in the workshop, kitchen, closet, office and on shelves without any problems possible. The insert box for storage has a storage cover that protects against external influences. A small box for big tasks!



Inklusive praktischer Staubdeckel zum Verschließen der Inserts

Practical dust cover to close the Inserts



Kleine VE's im Cutcase
Small PU's in Cutcase

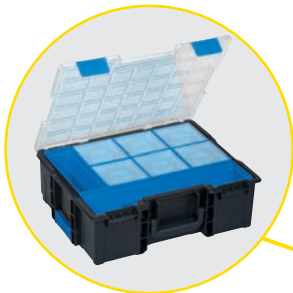

EuroPlus Pro >K< 44.144
(siehe S. 64 / See p. 64)



EuroPlus Pro >M<
(siehe S. 76 / See p. 76)



EuroPlus Pro >KC< 44.150
(siehe S. 68 / See p. 68)



McPlus Carry 40
(siehe S. 50 / See p. 50)

6 EuroPlus Insert >L<130/3	456340(5)		108 x 108 x 130	93 x 93 x 127	20	5
7 EuroPlus Insert >L<130/3	456341(2)		108 x 108 x 130	93 x 93 x 127	20	5

EAN = 4005187 + Art. Nr. ohne führende „4“ + Prüfziffer (X) / EAN = 4005187 + Art. No. without leading “4” + check digit (X)



ProServe Insert Set 1 und 2 (siehe S. 78)
ProServe Inset Set 1 and 2 (see p. 78)

Einsatzboxen-Set mit Anti-Rutschmatte

Gemäß Industriennorm passend für Schubladen- und Schranksysteme, Schubladengrößen 450 x 500 mm, 325 x 650 mm. Boxen aus hochschlagfestem Polystyrol, im verkaufstarken 4-Farb-Karton.

Set of insert bins with anti-slip mat

Suitable for industrial standard for drawer and cabinet systems, drawer sizes 450 x 500 mm, 325 x 650 mm. Boxes made of high-impact polystyrene, supplied in a sales-boosting 4-colour carton.

Besteht aus: / Consists of:

- 6 x 456305
- 6 x 456306
- 3 x 456307
- 3 x 456308
- 3 x 456309

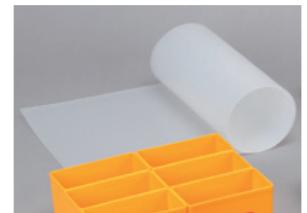

Mit Anti-Rutschmatte 250 x 900 mm
With anti-slide foil 250 x 900 mm

1



1 EuroPlus Set 63/22 (Insert)

457370(1)



405 x 335 x 140

1

5

EAN = 4005187 + Art. Nr. ohne führende „4“ + Prüfziffer (X) / EAN = 4005187 + Art. No. without leading “4” + check digit (X)



Kleinteilebox aus Kunststoff mit fester Facheinteilung

Die Kleinteileboxen in drei unterschiedlichen Größen schaffen Ordnung und sorgen für ein breites Anwendungsspektrum in Werkstatt und Haushalt oder beim Hobby.

Plastic small parts boxes with fixed compartments

The small parts boxes in three different sizes keep things tidy in workshop, home or hobby environments. Clever partitions provide a broad spectrum of use.



Millimeterskalen im Deckel und Aufhängemöglichkeit auf der Rückseite
Millimeter scales in the lid and cutouts on the back

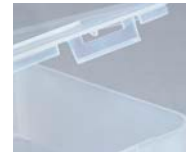

Transparenter Deckel mit stabilen Schnappverschlüssen
Transparent lid with sturdy snap closures



Optimale Sicht auf den Inhalt durch transparentes Material
Optimum visibility of box content thanks to transparent material



Stapelbar durch Erhöhungen in Deckel und Boden
Stackable thanks to raised areas in the lid and base



Kleine VE's in ansprechendem Cutcase
Small PU's in an attractive Cutcase



mm



mm



1 EuroPlus Box >D< 1	457405(0)		58 x 79 x 46	51 x 62 x 36	147	5
2 EuroPlus Box >D< 2	457406(7)		118 x 79 x 46	112 x 62 x 36	74	5
3 EuroPlus Box >D< 3	457407(4)		239 x 79 x 46	232 x 62 x 36	35	5

EAN = 4005187 + Art. Nr. ohne führende „4“ + Prüfziffer (X) / EAN = 4005187 + Art. No. without leading “4” + check digit (X)

Kunststoff-Sortimentskästen mit herausnehmbaren Einsatzboxen

Die flexiblen und vielseitigen Sortimentskästen mit „Pfiff“. Sinnvoll dimensionierte herausnehmbare Einsatzboxen mit drei zusätzlichen, festen Fächern bieten Platz für z. B. Zollstock und Schraubendreher.

Plastic assortment boxes with loose insert bins

Variable and versatile assortment boxes with “pizzazz”: Cleverly dimensioned, removable insert bins with three extra compartments offer plenty of space for items such as folding rulers and screwdrivers.



Führungsnuten im Deckel sichern die Sortierung

Secure assorting due to the locking knobs in the lid



Einrastnoppen verhindern Verrutschen der Einsatzboxen

Locking knobs prevent insert bins from shifting



Entnehmbare Einsatzboxen

Removable insert boxes



mm



mm



	EAN	Icon	Dimensions (mm)	Dimensions (mm)	Box Icon	Truck Icon
1 EuroPlus Flex 37-12	457200(1)		370 x 295 x 55	325 x 215 x 45	6	5
2 EuroPlus Flex 37-15	457201(8)		370 x 295 x 55	325 x 215 x 45	6	5
3 EuroPlus Flex 37-17	457202(5)		370 x 295 x 55	325 x 215 x 45	6	5
4 EuroPlus Flex 37-27	457203(2)		370 x 295 x 55	325 x 215 x 45	6	5
5 EuroPlus Flex 37-3	457204(9)		370 x 295 x 55	325 x 215 x 45	6	5

EAN = 4005187 + Art. Nr. ohne führende „4“ + Prüzfiffer (X) / EAN = 4005187 + Art. No. without leading “4” + check digit (X)



Platz für jeden Nutzen

EuroPlus Flex Sortimentskästen bieten für alle Fälle eine ordentliche Übersicht, z. B. für Büromittel, Nähutensilien, Eisenwaren, Beschläge usw.

Storage space for a thousand and one uses

EuroPlus Flex assortment boxes provide reliable organisation and clear view of items such as office supplies, sewing supplies, hardware, fittings etc.



Einsatzboxen verrutschen nicht
Insertboxes don't slip away

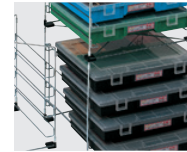

Drahtregal-System für 4x EuroPlus Flex 37 (siehe S. 90)
Wire-rack system holding 4x EuroPlus Flex 37 (see p. 90)



PO.S.-optimierte Zusammenstellung von EuroPlus Insert und Flex 37
PO.S.-optimised presentation of EuroPlus Insert & Flex 37

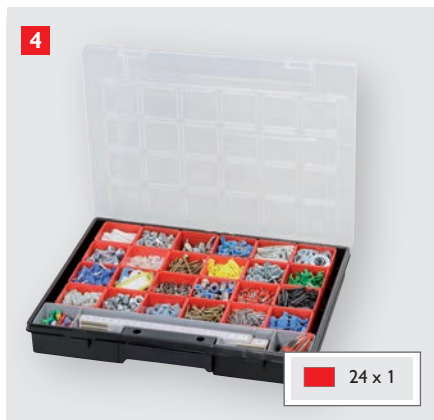

Kunststoff-Sortimentskästen mit Griff und flexibler Facheinteilung

Die Profi-Sortimentskästen schaffen Ordnung in Werkstatt und Haushalt oder beim Hobby. Flexible Trennstege sorgen für ein breites Anwendungsspektrum. Der innovative Flügeldeckel mit Rasteroptik ist mit einem stabilen Verschlusschieber ausgestattet. Der Deckel hält den Inhalt fest verschlossen.

Plastic assortment boxes with handle & variable compartments

The professional assortment boxes help to organise the workshop and the home. Removable dividers ensure maximum versatility. The innovative two-part lid with grid design is equipped with a sturdy slider lock. The lid sits tightly on the box and thus keeps the items inside in place.



Führungsnuten im Deckel sichern den Inhalt
Guide grooves in the lid secure the items inside



Mit handelsüblichem Vorhängeschloss abschließbar
Lockable with a standard padlock

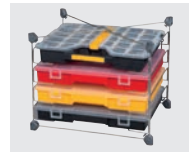

Optionales Regal mit EuroPlus Depot 37 (siehe S. 90)
Optional shelf with EuroPlus Depot 37 (see page 90)



i Fächermaße (siehe S. 86)
Compartments dimensions (see p. 86)



1	EuroPlus Basic >S<29/5-12	457410(4)		295 x 235 x 55	10	5
2	EuroPlus Basic >S<37/6-20	457420(3)		365 x 295 x 62	6	5
3	EuroPlus Basic >S<47/7-36		465 x 375 x 72	6	5	

EAN = 4005187 + Art. Nr. ohne führende „4“ + Prüfziffer (X) / EAN = 4005187 + Art. No. without leading “4” + check digit (X)



Kunststoff-Profi-Sortimentskasten-Sets mit Verbindungsclip

Der innovative Verbindungsclip ermöglicht die sichere Stapelung und den einfachen Transport der Sortimentskästen. Durch die stabilen Verschlüsse und die fest schließenden Deckel sind die Sortimentskästen auch ohne Durchmischung des Inhalts senkrecht zu tragen. Die individuelle Aufteilung mit flexiblen Trennstegen mit Schwalbenschwanzführung sorgt für ein breites Anwendungsspektrum.



Auch in verbundenem Zustand tragbar
The connection clip ensures safe transport of box sets



Kästen sind rutschticher verbunden
Cases are safely connected

Plastic assortment boxes with connection clip - smart sets for professionals!

Allit's innovative connection clip ensures safe stacking and hassle-free transport of assortment boxes. Thanks to the sturdy latches and the tight-fitting lid, the assortment boxes can be carried upright without the risk of contents getting mixed up. Customisable compartments with flexible dividers in dovetailed guides make the sets fit for a thousand and one uses.



Auch in ansprechenden Verkaufskarton
Also in attractive sales box.

i Fächermaße (siehe S. 86)
Compartments dimensions (see p. 86)

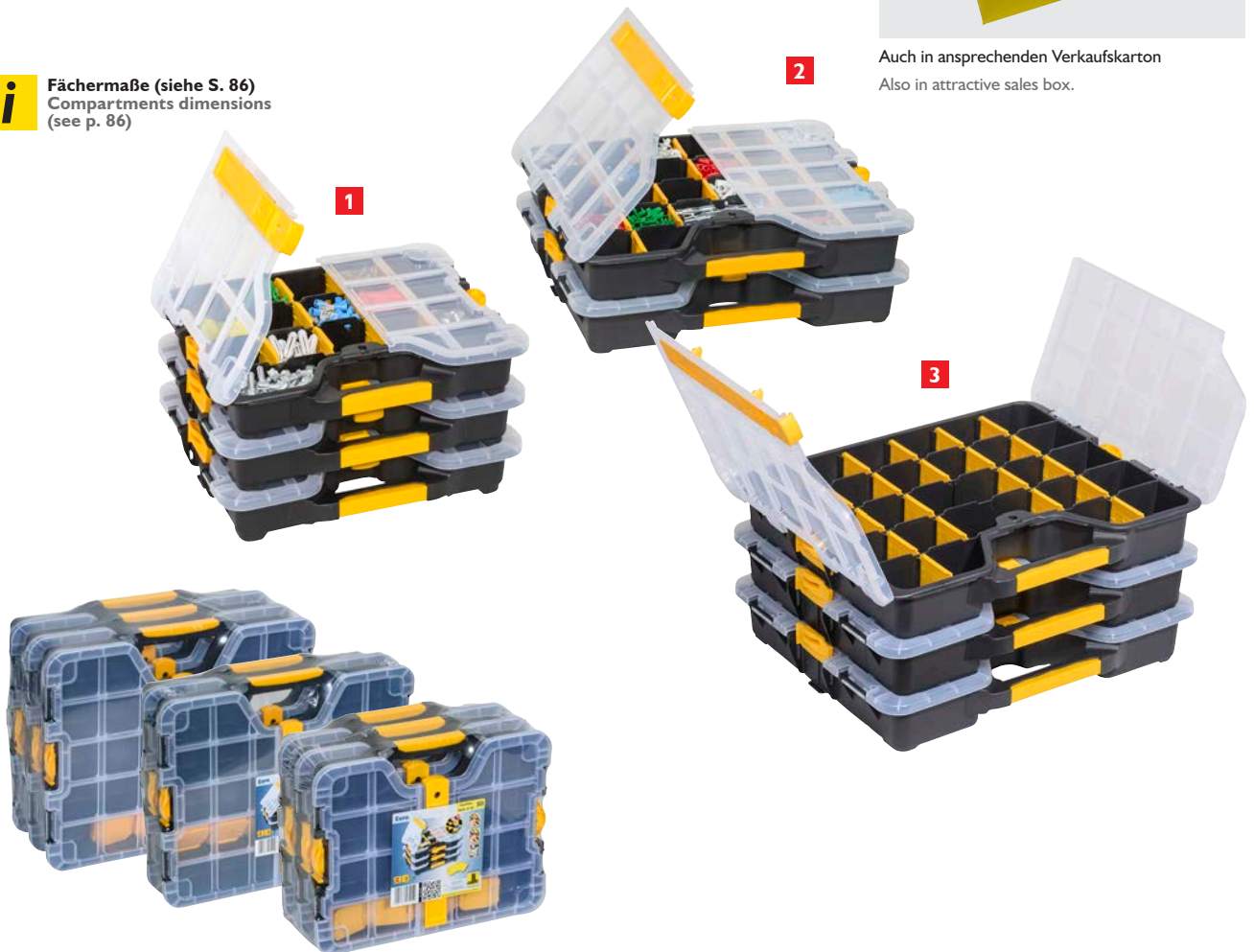

1 EuroPlus Basic >S<29 3i1

2 EuroPlus Basic >S<37 2i1

3 EuroPlus Basic >S<37 3i1



mm



457415(9)		295 x 235 x 155	3	90
457425(8)		365 x 295 x 125	3	90
457426(5)		365 x 295 x 185	2	90

EAN = 4005187 + Art. Nr. ohne führende „4“ + Prüfziffer (X) / EAN = 4005187 + Art. No. without leading “4” + check digit (X)

Entnehmen Sie die Fächeranzahl- und Maße der Allit Sortimentskästen dieser Tabelle
 Please refer to this table for detailed information about the number of compartments and the dimensions of Allit assortment boxes

- A** Breite Außen / Outside width
- B** Tiefe Außen / Outside depth
- C** Höhe Außen / Outside height
- G** Anzahl Fächer / Number of compartments
- H** Breite Fächer / Compartment width
- I** Höhe Fächer / Compartment height
- J** Tiefe Fächer / Compartment depth

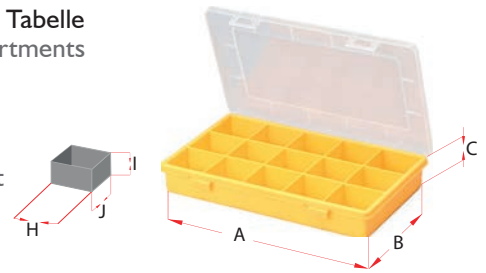

	Außen / Outside			Anzahl / Number	Fächer / Compartments		
	A	B	C	G	H	I	J
Feste Einteilung / Fixed Compartments							
EuroPlus Basic 12/2	120	205	44	1	176	36	60
				1	176	36	40
EuroPlus Basic 12/6	120	205	44	3	57	36	40
				3	57	36	60
EuroPlus Basic 18/1	180	150	40	1	165	34	120
EuroPlus Basic 18/6	180	150	40	4	53	34	38
				1	53	34	80
				1	165	34	38
EuroPlus Basic 18/7	180	150	40	1	165	34	38
				6	24	34	80
EuroPlus Basic 18/9	180	150	40	9	53	34	38
EuroPlus Basic 29/9	290	185	46	6	50	36	45
				1	270	36	45
				2	50	36	100
EuroPlus Basic 29/15	290	185	46	15	50	36	45
EuroPlus Basic 37/12	370	295	60	1	110	49	100
				4	55	49	45
				2	55	49	30
				4	110	49	45
				1	345	49	100
EuroPlus Basic 37/15	370	295	60	14	110	49	45
				1	110	49	30
EuroPlus Basic 37/25	370	295	60	4	110	49	45
				1	110	49	30
				20	55	49	45
Variable Einteilung / Variable Compartments							
EuroPlus Basic 11/2-4	175	120	44	1	152	42	51
				1	152	42	36
EuroPlus Basic 17/2-6	175	140	30	1	67	20	94
				1	37	20	94
EuroPlus Basic 29/3-12	290	185	46	3	270	36	40
EuroPlus Basic 37/7-20	370	295	60	2	110	49	45
				1	110	49	30
				4	345	49	45
EuroPlus Basic ›S◁ 29/5-12	295	235	55	3	245	35	40
				2	50	35	35
EuroPlus Basic ›S◁ 37/6-20	365	295	65	3	315	50	45
				2	82	50	45
				1	315	50	20
EuroPlus Basic ›S◁ 47/7-36	465	375	72	4	415	60	45
				2	105	60	45
				1	415	60	30



Kunststoff-Sortimentskästen mit fester oder flexibler Facheinteilung

Die Sortimentskästen in drei Größen und Fächervarianten schaffen Ordnung in der Werkstatt, im Haushalt oder beim Hobby.

Plastic assortment boxes with fixed or flexible compartments

These organiser boxes are available in three sizes and compartment configurations – ideal for workshop, home and leisure use.



Deckel schließt fest mit Fächern ab
The lid sits tightly on the compartments



Solide Verschlüsse gegen unbeabsichtigtes Öffnen
Sturdy fasteners prevent accidental opening



Individuelle Einteilung der Fächer durch herausnehmbare Trenntege
Customised compartments thanks to removable dividers



Auf Anfrage mit Euro-Aufhängung
Optionally available with EURO slot hanger



Auf Anfrage EuroPlus Basic 18/6 und 18/9 in Schwarz/Transparent
On request EuroPlus Basic 18/6 and 18/9 in black/transparent



Inhalt immer gut sichtbar
Full visibility of the items inside

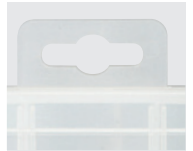

EuroPlus Basic 18 optional auch mit Euro-Aufhängung
EuroPlus Basic 18 available with Euro norm attachment



i Fächermaße (siehe S. 86)
Compartments dimensions (see p. 86)



1	EuroPlus Basic 11/2-4		457160(8)	175 x 120 x 44	8	5
2	EuroPlus Basic 12/6		457166(0)	120 x 205 x 44	16	5
3	EuroPlus Basic 17/2-6		457168(4)	175 x 140 x 30	16	5
4	EuroPlus Basic 18/1		457170(7)	180 x 150 x 40	10	5
5	EuroPlus Basic 18/6		457175(2)	180 x 150 x 40	10	5
6	EuroPlus Basic 18/7		457180(6)	180 x 150 x 40	10	5
7	EuroPlus Basic 18/9		457190(5)	180 x 150 x 40	10	5
8	EuroPlus Basic 18/9		457195(0)	180 x 150 x 40	10	5

EAN = 4005187 + Art. Nr. ohne führende „4“ + Prüfziffer (X) / EAN = 4005187 + Art. No. without leading “4” + check digit (X)

Kunststoff-Sortimentskästen mit fester oder flexibler Facheinteilung

Die Sortimentskästen EuroPlus Basic 29 mit festen Fächern oder flexiblen Trennstegen. In verschiedenen Farben sind sie bewährte Ordnungshelfer in der Werkstatt, im Haushalt oder beim Hobby.

Plastic assortment boxes with fixed or flexible compartments

EuroPlus Basic 29 assortment boxes with fixed compartments or variable dividers. They come in a variety of colours and are useful storage helpers for workshop, home and leisure use.



Auf Anfrage mit Euro-Aufhängung
Optionally available with EURO slot hanger

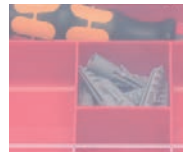

Deckel schließt fest mit Fächern ab
The lid sits tightly on the compartments

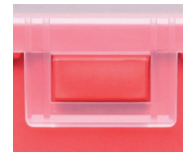

Solide Verschlüsse gegen unbeabsichtigtes Öffnen
Sturdy latches prevent accidental opening



Individuelle Einteilung der Fächer
Customisable compartments

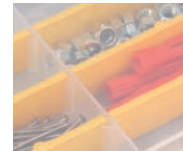

Inhalt immer gut sichtbar
Full visibility of the items inside



EuroPlus Basic 29 optional auch mit Euro-Aufhängung
EuroPlus Basic 29 optionally available with EURO slot hanger



i Fächermaße (siehe S. 86)
Compartments dimensions (see p. 86)



1 EuroPlus Basic 29/9

457210(0)



290 x 185 x 46

10

5

2 EuroPlus Basic 29/15

457220(9)



290 x 185 x 46

10

5

3 EuroPlus Basic 29/3-12

457225(4)



290 x 185 x 46

10

5

EAN = 4005187 + Art. Nr. ohne führende „4“ + Prüfziffer (X) / EAN = 4005187 + Art. No. without leading “4” + check digit (X)



Kunststoff-Sortimentskästen mit fester und flexibler Facheinteilung

Die Sortimentskästen EuroPlus Basic 37 mit vier verschiedenen Fächervarianten schaffen Ordnung in der Werkstatt, im Haushalt oder beim Hobby. Feste bzw. flexible Facheinteilungen sorgen für ein breites Anwendungsspektrum.

Plastic assortment boxes with fixed or flexible compartments

Assortment boxes EuroPlus Basic 37 are available in four different sizes and many compartment variations. They keep things well organised in the workshop or in the household. Fixed or flexible compartments make these boxes extremely versatile.



4
Individuelle Einteilung der Fächer
Customised compartments



Deckel schließt fest mit Fächern ab
The lid sits tightly on the compartments

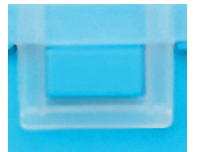

Solide Verschlüsse gegen unbeabsichtigtes Öffnen
Sturdy latches prevent accidental opening



Inhalt immer gut sichtbar
Full visibility of the items inside



Drahtregal-System für 4x EuroPlus Basic 37 (siehe S. 90)
Wire-rack system holding four EuroPlus Basic 37 boxes (see p. 90)



i Fächermaße (siehe S. 86)
Compartments dimensions (see p. 86)



mm



1	EuroPlus Basic 37/12		370 x 295 x 60	6	5
2	EuroPlus Basic 37/15		370 x 295 x 60	6	5
3	EuroPlus Basic 37/25		370 x 295 x 60	6	5
4	EuroPlus Basic 37/7-20		370 x 295 x 60	6	5

EAN = 4005187 + Art. Nr. ohne führende „4“ + Prüfziffer (X) / EAN = 4005187 + Art. No. without leading “4” + check digit (X)

Regal für Sortimentskästen EuroPlus 37

Die unentbehrliche Arbeitsplatzausstattung für eine schnelle und übersichtliche Bereitstellung von Kleinteilen und Zubehör.

Rack for assortment boxes EuroPlus 37

The indispensable workplace equipment for prompt and well-organised availability of small parts and accessories of any type.



4x EuroPlus Basic 37 (siehe S. 89)



4x EuroPlus Flex 37 (siehe S. 82)



4x EuroPlus Basic 37 (siehe S. 84)

4x EuroPlus Basic 37 (see p. 89)

4x EuroPlus Flex 37 (see p. 82)

4x EuroPlus Basic 37 (see p. 84)



Verbesserte Verbindungstechnik aus Kunststoff
Enhanced plastic fasteners



Verbesserte Stapelfähigkeit
Improved stackability



Im absatzstarken 4-Farb-Karton
Packed in a salesboosting 4-colour carton



1

Kunststoff-Sortimentskasten-Set

Verkaufsförderndes Set mit vier Sortimentskästen und fester Facheinteilung in unterschiedlichen Größen. Das in Folie eingeschweißte Set bietet 45 unterschiedliche Einteilungsmöglichkeiten für Kleinteile und durch die transparenten Deckel ist der Inhalt immer sichtbar.

Set of plastic organiser boxes

Sales-boosting set comprised of four assortment boxes and fixed compartments in different sizes. The shrink-wrapped set offers 45 different compartment options for small parts. Thanks to the transparent lid, the items inside are always visible.



2

- Bestehend aus: / Consists of:**
- 2 x 457190
 - 1 x 457220
 - 1 x 457230

Sondervarianten auf Anfrage: / Special variants on request:

EP001

- 2 x 457191
- 1 x 457212
- 1 x 457240

EP002

- 2 x 457160
- 1 x 457225
- 1 x 457234



EP001

EP002



mm



455800(5)



405 x 320 x 345

2

5

457360(2)



370 x 295 x 100

3

a.A.*

1 EuroPlus Depot 37

2 EuroPlus Set 45

EAN = 4005187 + Art. Nr. ohne führende „4“ + Prüfziffer (X) / EAN = 4005187 + Art. No. without leading “4” + check digit (X)

* a.A. = auf Anfrage / Upon request



Kunststoff-Doppel-Sortimentskasten mit herausnehmbaren Trennstegen

Der doppelseitiger Sortimentskasten mit extra vielen Fächer bietet eine sichere Sortierung für unterwegs und im Regal. Fächer und Trennstege schließen mit transparentem Deckel ab und verhindern so ein Durchmischen des Inhalts. Der Doppel-Sortimentskasten kann stehend und liegend gelagert werden.

Plastic twin organiser boxes with removable dividers

The double-sided assortment box with extra compartments offers secure sorting on the go and on the shelf. Drawers and dividers close with a transparent lid to prevent mixing of the contents. The double assortment box can be stored standing and lying.



Ergonomischer Tragegriff
Ergonomic handle



Individuelle Aufteilung mit 30 variablen Trennstegen
Customised partitioning thanks to 30 flexible dividers

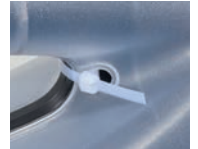

Mit handelsüblichen Kabelbindern abschließbar
Lockable with standard cable ties

Sortimentskästen mit herausnehmbaren Einsatzboxen

Ausgestattet mit transparentem Deckel, stabilen Schnappverschlüssen und vielen verschieden großen Einsatzboxen, ist der Sortimentskasten ein praktischer Helfer für Werkstatt, Haushalt und Hobby.

Organiser boxes with removable internal containers

Equipped with transparent lid, sturdy snap fasteners and many different sized insert boxes, the assortment box is a practical helper for workshop, household and hobby.



Herausnehmbare Einsatzboxen
Removable internal containers



Ergonomischer Griff
Ergonomic handle



Fächermaße

Compartments dimensions



5x 91 x 91 x 45 mm
8x 91 x 43 x 45 mm
8x 43 x 43 x 45 mm



mm



mm



1	EuroPlus Duo 38/12-42	457235(3)		380 x 290 x 80	-	5	5
2	EuroPlus Flex 42-21	457206(3)		410 x 330 x 60	390 x 240 x 46	7	5

EAN = 4005187 + Art. Nr. ohne führende „4“ + Prüfziffer (X) / EAN = 4005187 + Art. No. without leading “4” + check digit (X)

Mit Hilfe der Kleinteile- und Klappschüttenmagazine aus Kunststoff und Metall in vielen verschiedenen Varianten sind alle Kleinteile auf der Werkbank oder an der Wand jederzeit übersichtlich verfügbar.

Small parts of any type can be neatly organised on the workbench or near the wall thanks to the extensive range of small parts storage cabinets and tip-out storage bin cabinets designed in plastic and metal and available in many different models.

VarioPlus ProFlip

94

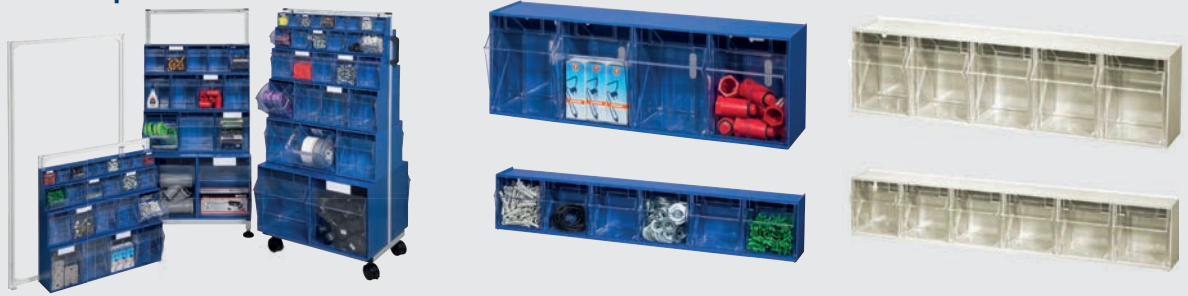

VarioPlus Pro

96



VarioPlus Pro >R<

98



VarioPlus ProExtra

100



VarioPlus Pro ›M‹

101



VarioPlus Pro ›RM‹

102



VarioPlus Metall
VarioPlus Basic & Basic ›D‹
VarioPlus DrawBox
VarioPlus Extra
VarioPlus Depot ›M‹

103

104

105

106

107



Für staubfreie Sichtlagerung

Klappschütten herausklippbar und herausnehmbar, dadurch leichtes Befüllen und Entnehmen. Aufeinander-setzbar oder an der Wand zu befestigen, kombinierbar ausbaufähig bis zur Großanlage. Wandrahmen, Stand- und Fahrregal erhältlich mit innovativem Befestigungssystem.

For dust-protected storage

Tip-out bins can be tilted and removed from the frame for easy access, picking and refilling. Stackable or wall-mountable, modular/combinable, can be expanded into a larger system as required. Wall frame, stationary and mobile rack available with an innovative attachment system.



Zur Fixierung im Rahmen
Fixes the casing to the frame



Knopf einstecken
Introduce the knob



Knopf fixieren
Push the knob in place



Gehäuse einhängen
Suspend the casing



Gehäuse positionieren – Fertig –
Position the casing – and you are done!



Inhalt stets gut sichtbar und staubgeschützt
Stored items are visible and protected from dust



Optionales Zubehör verhindert das unbeabsichtigte Öffnen der Klappschütte
Optional accessory items prevent inadvertent opening of tip-out bins





Metall, Gummi / Metal, rubber

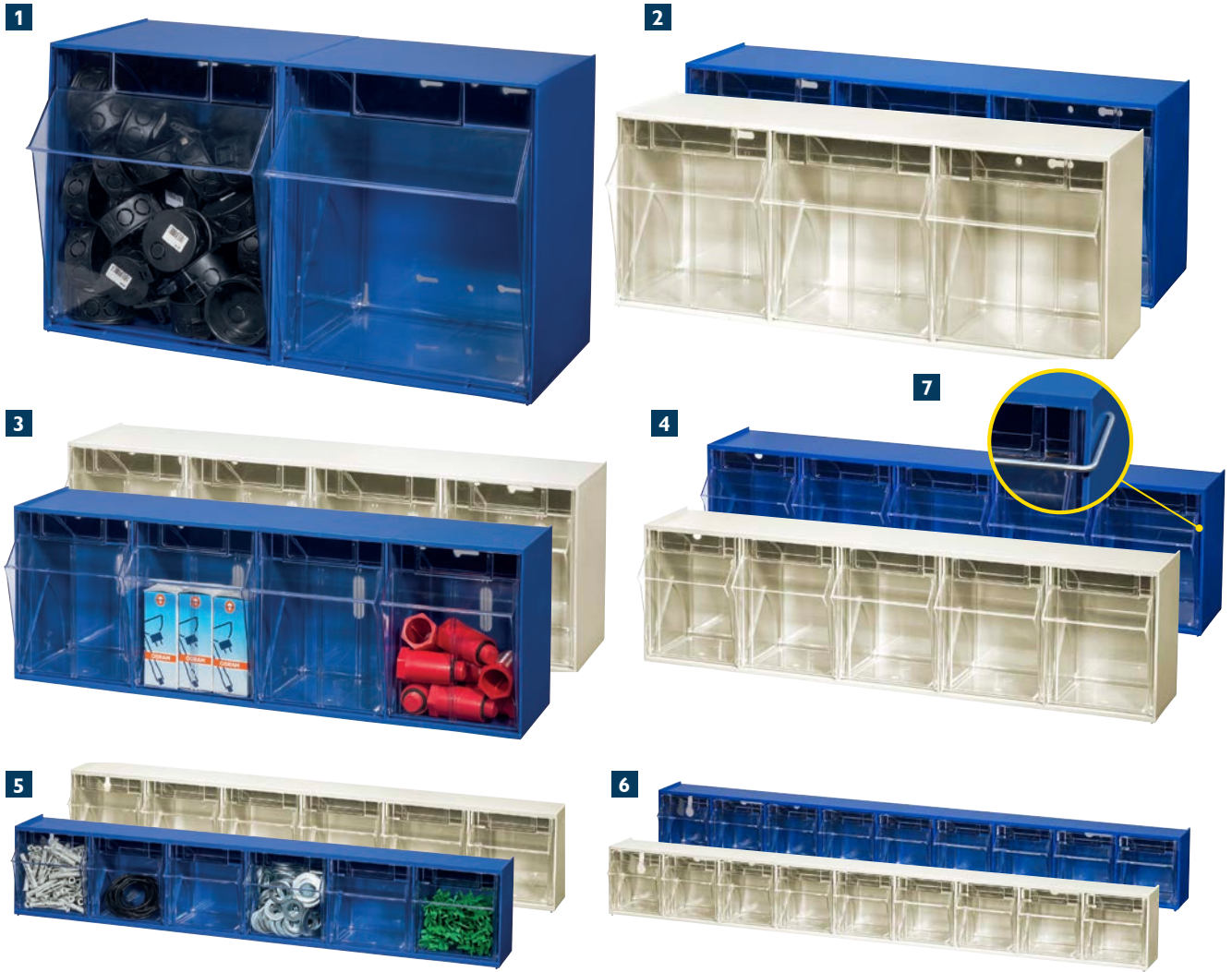

	EAN	Color	mm	mm	mm	mm	mm	mm
1 VarioPlus ProFlip 2	464400(5)		600 x 310 x 350	2 x 265 x 205 x 245	24	1	5	
2 VarioPlus ProFlip 3	464410(4)		600 x 200 x 240	3 x 176 x 140 x 160	54	1	5	
2 VarioPlus ProFlip 3	464411(1)		600 x 200 x 240	3 x 176 x 140 x 160	54	1	5	
3 VarioPlus ProFlip 4	464420(3)		600 x 170 x 205	4 x 125 x 122 x 135	72	1	5	
3 VarioPlus ProFlip 4	464421(0)		600 x 170 x 205	4 x 125 x 122 x 135	72	1	5	
4 VarioPlus ProFlip 5	464430(2)		600 x 135 x 165	5 x 99 x 95 x 107	117	1	5	
4 VarioPlus ProFlip 5	464431(9)		600 x 135 x 165	5 x 99 x 95 x 107	117	1	5	
5 VarioPlus ProFlip 6	464440(1)		600 x 95 x 115	6 x 79 x 65 x 69	216	1	5	
5 VarioPlus ProFlip 6	464441(8)		600 x 95 x 115	6 x 79 x 65 x 69	216	1	5	
6 VarioPlus ProFlip 9	464450(0)		600 x 65 x 77	9 x 48 x 44 x 46	468	1	5	
6 VarioPlus ProFlip 9	464451(7)		600 x 65 x 77	9 x 48 x 44 x 46	468	1	5	
7 VarioPlus ProFlip LockBar	464500(2)		610 x 52 x 3	-	5000	1	5	
8 VarioPlus ProFlip >WD< 60	464550(7)		600 x 40 x 615	-	414	1	5	
9 VarioPlus ProFlip >WD< 116	464560(6)		600 x 40 x 1175	-	162	1	5	
10 VarioPlus ProFlip >D< 116	464570(5)		600 x 310 x 1250	-	88	1	5	
11 VarioPlus ProFlip >RD< 116	464580(4)		660 x 480 x 1285	-	56	1	5	

EAN = 4005187 + Art. Nr. ohne führende „4“ + Prüfziffer (X) / EAN = 4005187 + Art. No. without leading “4” + check digit (X)

Profi-Kunststoffmagazine mit Trennstegen für Kleinteile und größere Gegenstände

Besonders vielseitige Einsatzmöglichkeiten durch kleine und große Schubladen. Zwei Gehäusegrößen mit unterschiedlichen Bestückungsvarianten. Trennstege im Lieferumfang enthalten.

Professional plastic drawer cabinets with dividers for small parts and larger items

Small and large plastic drawers allow for a thousand and one uses. Two frame sizes – many configuration options. The cabinets come complete with dividers.



Ablagefach im Deckel für Werkzeuge oder Kleinteile
Compartment for tools or small parts integrated in the lid



Für Wandaufhängung vorbereitet
Prepared for wall mounting



Schubladen gegen Herausfallen gesichert
Drawers are secured against falling out

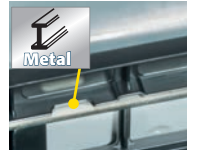

Stahlleisten für höhere Stabilität
Steel reinforcements for higher stability



Individuelle Einteilung der Schubladen
Customisable drawer compartments

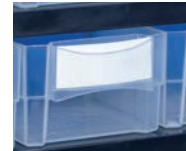

Beschriftungsetiketten als Download-Vorlage
Lettering labels as a download template



Hochtransparente Schublade auf Anfrage
Highly transparent drawer on request



mm



1	VarioPlus Pro 29/32	464600(9)		300 x 135 x 285	1	5
2	VarioPlus Pro 29/35	464610(8)		300 x 135 x 285	1	5
3	VarioPlus Pro 29/50	464620(7)		300 x 135 x 285	1	5
4	VarioPlus Pro 53/20	464630(6)		300 x 165 x 525	1	5
5	VarioPlus Pro 53/21	464640(5)		300 x 135 x 525	1	5
6	VarioPlus Pro 53/60	464650(4)		300 x 135 x 525	1	5
7	VarioPlus Pro 53/100	464660(3)		300 x 135 x 525	1	5

EAN = 4005187 + Art. Nr. ohne führende „4“ + Prüzfiffer (X) / EAN = 4005187 + Art. No. without leading “4” + check digit (X)



Metall / Metal



1



2



3

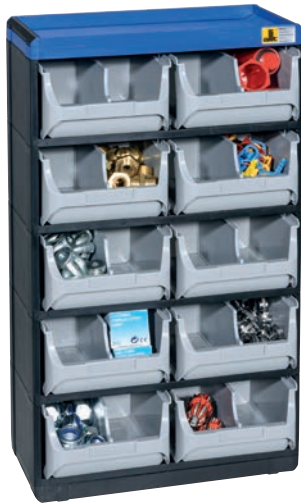

4



















5



6



7

Artikel	E2		A2		B2		C2		2D2		2B2		2C2		ProfiPlus Box 2B		
																	
1 VarioPlus Pro 29/32	464600	5	5	8	8					3	3						
2 VarioPlus Pro 29/35	464610	10	10	4	4	2	2	1	2								
3 VarioPlus Pro 29/50	464620	25	25														
4 VarioPlus Pro 53/20	464630															10	10
5 VarioPlus Pro 53/21	464640									3	3	6	6	1	2		
6 VarioPlus Pro 53/60	464650	15	15	8	8	2	2			3	3	2	2				
7 VarioPlus Pro 53/100	464660	50	50														

Individuell bestückbares Drehmagazin für Werkstatt, Lager, Markt und Labor

Das selbst bestückbare Drehmagazine sorgt für die nötige Ordnung auf kleinstem Raum. Durch die Möglichkeit, das Drehmagazin durch unterschiedlichste Kleinteilemagazine selbst zu gestalten, kann ein ganz individueller Aufbewahrungsort für den jeweiligen Nutzen geschaffen werden.

Individually equippable rotary magazine for workshops, warehouses, markets and laboratories

The self-loading rotary magazine ensures the necessary order in the smallest of spaces. By the possibility that Designing a rotary magazine yourself with a wide variety of small parts magazines can be a very individual place of storage created for the respective benefit.

464630

464640

464650

464660

1

1.710 mm

610 mm

445

445

VarioPlus Pro >R< 171
Drehständer wird ohne Klein-
teilmagazine geliefert. Individuell
bestückbar.

The rotating stand is supplied wi-
thout small parts cabinets; it can be
organised as you wish.

i
Mehr zu ProfiPlus Boxen
(siehe S. 110)
For more on ProfiPlus boxes
(see p. 110)

1 VarioPlus Pro >R< 171



464665(8)



mm



1



5

EAN = 4005187 + Art. Nr. ohne führende „4“ + Prüfziffer (X) / EAN = 4005187 + Art. No. without leading “4” + check digit (X)



Metall / Metal

Drehmagazine für Werkstatt, Lager, Markt und Labor

Ordnung auf kleinstem Raum bieten unsere Kleinteile-Drehmagazine. Komplett bestückt mit sieben verschiedenen Schubladentypen und/oder Stapelsichtboxen bietet diese Produktlinie vielfältige Kombinationsmöglichkeiten für den Anwender. Die jeweiligen Inhalte sind schnell Verfügbar durch 360° Drehung des Magazins.

Rotating storage cabinets for workshops, warehouses, stores and laboratories

Great ideas for tiny spaces: our rotating small parts cabinets featuring an elegantly streamlined “high-rise” shape provide lots of room for smart organisation. The product line comes equipped with seven different types of drawers and/or open-fronted stackable storage bins that offer countless combination options and many benefits. The respective contents are fast available by rotating the magazine 360°.



Stapelsichtboxen können entnommen werden.

Stackable view boxes can be removed.



2

3

2 VarioPlus Pro >R< 187/494
Drehmagazin mit Drehteller, 2x 18-zeilig, 2x 36-zeilig, bestückt mit 282 Schubladen.

Rotating cabinet mounted on a floor turntable, comes with 2 x 18 rows, 2 x 36 rows, equipped with 282 drawers.

3 VarioPlus Pro >R< 178/136
Drehmagazin mit Drehteller, 4x17 Zeilig, bestückt mit 136 ProfiPlus Boxen

Rotating cabinet mounted on a floor turntable, complete with 4x17 rows and 136 boxes

i Mehr zu ProfiPlus Boxen (siehe S. 110)
For more on ProfiPlus boxes (see p. 110)

MAX 300 kg Mit einer hohen Traglast bis 300 kg bleibt das Drehteilmagazin selbst vollbeladen sicher und stabil.

With a high load capacity of up to 300 kg, the turned parts magazine remains safe and stable even when fully loaded.

Artikel	E2		A2		B2		C2		2D2		2B2		2C2		ProfiPlus Box 2B		
2 VarioPlus Pro >R< 187/494	464670	80	40	80	40	32	32	20	20	24	24	16	16	10	20	20	20
3 VarioPlus Pro >R< 178/136	464675	-	-	-	-	-	-	-	-	-	-	-	-	-	-	136	-



mm



2 VarioPlus Pro >R< 187/494	464670(2)		480 x 450 x 1870	1	5
3 VarioPlus Pro >R< 178/136	464675(7)		510 x 510 x 1780	1	5

EAN = 4005187 + Art. Nr. ohne führende „4“ + Prüfziffer (X) / EAN = 4005187 + Art. No. without leading “4” + check digit (X)

Schubladen, Trennsteg und Etiketten

Schubladen und Trennsteg aus hochtransparentem Polypropylen und maßgeschneiderte Beschriftungsetiketten sichern bestmögliche Ordnung und Übersicht. Passend für alle Kleinteilemagazine und Depots der Produktlinie VarioPlus Pro.

Drawers, dividers and labels

Drawers and dividers made of super transparent polypropylene as well as customised labels ensure perfect order and clarity. Suitable for all VarioPlus Pro small parts cabinets and depots.

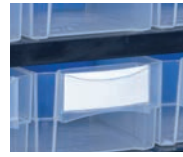

Beschriftungsetiketten als Download-Vorlage
Lettering labels as a download template



Schwabenschwanzführung für Trennsteg
Dovetail guides support dividers



Hochtransparente Schublade auf Anfrage
Highly transparent drawer on request

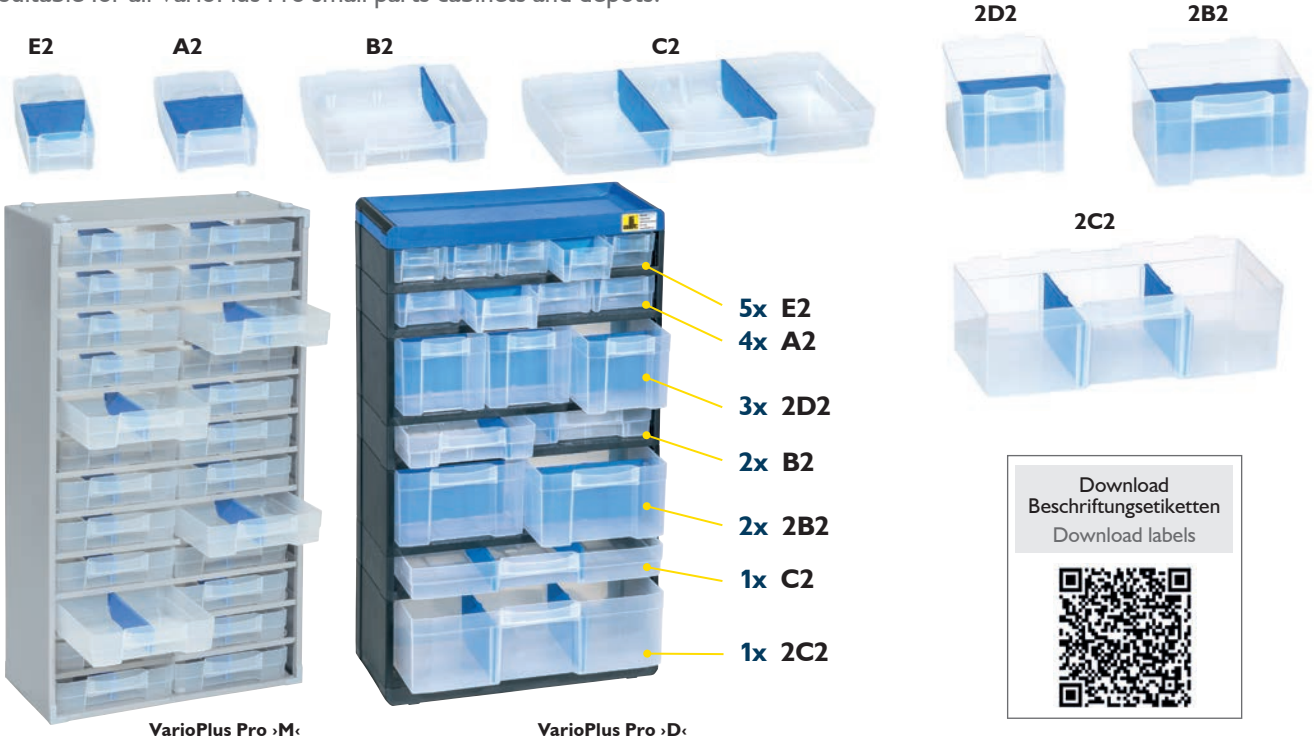

Download Beschriftungsetiketten
Download labels

	1*	2*	3*	4*	5*	6*	7*
Schubladen / Drawers	E2	A2	B2	C2	2D2	2B2	2C2
Außenmaße** (B x T x H) mm / Outside dim. (W x D x H) mm	54 x 130 x 36	68 x 130 x 36	138 x 130 x 38	274 x 130 x 36	90 x 130 x 84	138 x 130 x 82	274 x 130 x 84
Nutzmaße (B x T x H) mm / Usable dim. (W x D x H) mm	45 x 105 x 32	60 x 105 x 32	129 x 105 x 32	265 x 90 x 34	79 x 109 x 79	126 x 109 x 79	265 x 90 x 79
VE / PU	90	72	36	18	27	18	9
Art. Nr. (EAN)/Farbe <input type="checkbox"/> / Art. No. (EAN)/Colour <input type="checkbox"/>	464700(6)	464701(3)	464702(0)	464703(7)	464704(4)	464705(1)	464706(8)
Lieferzeit / Tage / Delivery time / days	5	5	5	5	5	5	5
Trennsteg / Dividers	E2	A2	B2	C2	2D2	2B2	2C2
VE ¹⁾ / PU ¹⁾	1(10)	1(10)	1(5)	1(5)	1(1)	1(1)	1(1)
Art. Nr. (EAN)/Farbe <input checked="" type="checkbox"/> / Art. No. (EAN)/Colour <input checked="" type="checkbox"/>	464720(4)	464721(1)	464726(6)	464722(8)	464723(5)	464724(2)	464725(9)
Lieferzeit / Tage / Delivery time / days	5	5	5	5	5	5	5
Beschriftungsetiketten auf Bogen / Slip-in labels on a sheet	Als Downloadvorlage erhältlich. Besuchen Sie unsere Website (www.allit.de) / Available as a download template – please feel free to visit our website (www.allit.de/en)						

EAN = 4005187 + Art. Nr. ohne führende „4“ + Prüfziffer (X) / EAN = 4005187 + Art. No. without leading “4” + check digit (X)

¹⁾ Angaben in Klammern = Packungsinhalt (Stück) / ¹⁾ information in brackets = quantity per pack (pieces)

* keine Barcodeauszeichnung / no barcode labeling

** Maße ohne Aushebesicherung / dimensions without lifting protection



Metall / Metal

Profi-Kleinteilemagazin aus Metall mit Trennstegen

Die großen Schubladen sind durch Trennstegen trennbar. Das Gehäuse ist aus schlagfestem Metall, durch die hochwertige Pulverbeschichtung sind scharfe Kanten abgerundet und eine lange Lebensdauer ist gewährleistet. Erhältlich in drei verschiedenen Bestückungsvarianten.

Professional small parts magazine made of metal with dividers

The large drawers are separable by dividers. The housing is made of impact-resistant metal, the high-quality powder coating, sharp edges are rounded and a long service life is guaranteed. Available in three different equipment variants.



Schubladen gegen Herausfallen gesichert
Drawers are secured against falling out

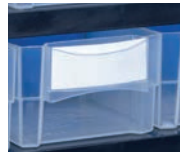

Beschriftungsetiketten als Download-Vorlage
Lettering labels as a download template



Individuelle Einteilung der Schubladen
Customisable drawer compartments



Für Wandaufhängung vorbereitet
Prepared for wall mounting



Keine scharfen Kanten
No sharp edges



Stapelnappe im Boden und Deckel
Stackingknobs in bottom and top



Hochtransparente Schublade auf Anfrage
Highly transparent drawer on request



B2 24x Schublade
24x Trennstege
24x drawers
24x dividers



E2 60x Schublade
60x Trennstege
60x drawers
60x dividers



C2 12x Schublade
24x Trennstege
12x drawers
24x dividers



1 VarioPlus Pro >M< 57/36	464800(3)		300 x 140 x 565	1	5
2 VarioPlus Pro >M< 57/48	464810(2)		300 x 140 x 565	1	5
3 VarioPlus Pro >M< 57/120	464830(0)		300 x 140 x 565	1	5

EAN = 4005187 + Art. Nr. ohne führende „4“ + Prüfziffer (X) / EAN = 4005187 + Art. No. without leading “4” + check digit (X)

Metall-Drehmagazin für Werkstatt, Lager, Markt und Labor

Ordnung auf kleinstem Raum bietet unser Kleinteile-Drehmagazin. Das Magazin kann individuell mit den Kleinteilemagazinen VarioPlus Pro >M< und VarioPlus Metall bestückt werden.

Rotating storage cabinets made of metal for workshops, warehouses, stores and laboratories

Great ideas for tiny spaces: our rotating small parts cabinet featuring an elegantly streamlined “high-rise” shape provide. It can be individually equipped with small parts cabinets VarioPlus Pro >M< and VarioPlus Metall.

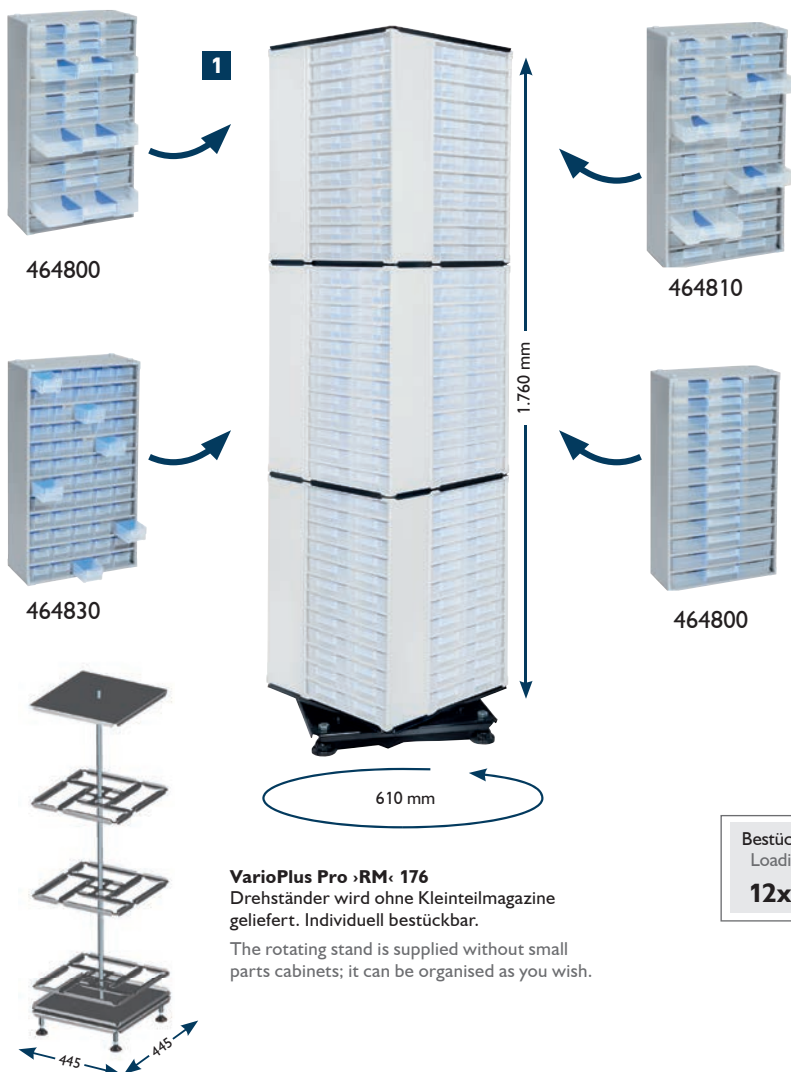

VarioPlus Pro >RM< 176
 Drehständer wird ohne Kleinteilemagazine geliefert. Individuell bestückbar.
 The rotating stand is supplied without small parts cabinets; it can be organised as you wish.

Bestückungsbeispiel
 Loading Example:
12x 464810



1	VarioPlus Pro >RM< 176	464840(9)	445 x 445 x 1760	1	5
----------	-------------------------------------	-----------	------------------	---	---

EAN = 4005187 + Art. Nr. ohne führende „4“ + Prüfwert (X) / EAN = 4005187 + Art. No. without leading “4” + check digit (X)



Stahlblech / Sheet steel

Stahlblech-Kleinteilemagazine mit Trennstegen

Höchste Qualität für den vielseitigen Einsatz in Industrie, Handwerk und Haushalt. Drei Gehäusegrößen mit unterschiedlichen Bestückungsvarianten. Das Metallmagazin hat eine hochwertige Pulverbeschichtung und keine scharfen Kanten am Gehäuse.

Steel frame small parts cabinets with dividers

Premium quality for a myriad of uses in industry, crafts and at home. Available in three different frame sizes and equipped with different sets of drawers. The metal cabinets feature a high-quality powder coating and are free from sharp edges.

Passend für VarioPlus Pro >RM< 176, (siehe S. 102)
Suitable for VarioPlus Pro >RM< 176, (see p. 102)



Einstecketiketten im Lieferumfang enthalten
Supplied with slip-in labels



Sichere Stapelung über Stapelnoppen möglich
Safe piling thanks to stacking knobs



Für Wandaufhängung vorbereitet
Prepared for wall mounting



Schubladen gegen Herausfallen gesichert
Drawers are secured against falling out



Individuelle Einteilung der Schubladen
Variable drawer compartments



Metallgehäuse und -böden
Metal frame and shelves



Fächermaße siehe S. 86
Compartment dimensions see p. 86



Modell	EAN	Farbe	Abmessungen (mm)	Teilezahl	Truck
1 VarioPlus Metall 73	465520(9)		300 x 140 x 565	2	5
2 VarioPlus Metall 90	465530(8)		300 x 140 x 565	2	5
3 VarioPlus Depot >M< 40	465610(7)		300 x 165 x 565	2	5
4 VarioPlus Depot >M< 52	465620(6)		300 x 140 x 565	2	5

EAN = 4005187 + Art. Nr. ohne führende „4“ + Prüfziffer (X) / EAN = 4005187 + Art. No. without leading “4” + check digit (X)

Kunststoff-Kleinteilemagazine und -depots mit Trennstegen

Bewährte Kunststoff-Kleinteilemagazine und -depots in verschiedenen Varianten für den universalen Nutzen mit gutem Preis-Leistungs-Verhältnis.

Plastic small parts storage cabinets and depots with dividers

Tried and tested plastic small parts cabinets and depots in various variants with an excellent price/quality ratio – ideal for a thousand and one uses!



Fächermaße siehe S. 86
Compartment dimensions check p. 86



Ablagefach im Deckel für Werkzeuge oder Kleinteile

Compartment for tools or small parts integrated in the lid



Für Wandaufhängung vorbereitet

Prepared for wall mounting



Individuelle Einteilung der Schubladen

Customisable drawer compartments

Download Einstecketiketten
Download slip-in labels



Schneller Umschlag als Zweitplatzierung
Fast turnaround as a secondary placement



mm



1	VarioPlus Basic 15	458080(8)		300 x 135 x 190	3	5
2	VarioPlus Basic 32	458090(7)		300 x 135 x 335	2	5
3	VarioPlus Basic >D< 21	458140(9)		305 x 170 x 435	2	5
4	VarioPlus Basic >D< 34	458160(7)		305 x 170 x 435	2	5
5	VarioPlus Basic 47	458100(3)		305 x 135 x 435	2	5
6	VarioPlus Basic 54	458120(1)		305 x 135 x 435	2	5

EAN = 4005187 + Art. Nr. ohne führende „4“ + Prüfziffer (X) / EAN = 4005187 + Art. No. without leading “4” + check digit (X)



Kunststoff-Klappschütten-Magazine mit Wandaufhängung und Tragegriff für Kleinteile

Die Magazine sind ideal für den mobilen Einsatz oder in der Werkstatt. Das stabile Kunststoffgehäuse gewährleistet eine schwere Befüllung. Der Klappdeckel schützt den Inhalt vor Verschmutzung und Herausfallen.

Plastic tio out bin magazines for wall mounting and/or carrying handle for small parts

The magazines are ideal for mobile use or in the workshop. The sturdy plastic housing ensures a heavy filling. The hinged lid protects the contents from dirt and falling out.



Haken mit Lang-Loch ermöglichen eine einfache Wandaufbringung
Hooks with elongated holes for easy wall attachment



Gehäuse mit einem Handgriff von der Wand abnehmbar
The frame can be easily removed from the wall



Tragegriff ermöglicht einfache Mitnahme
Carrying handle enables easy carrying



Sicherheit & Platz durch 4-Punkt-Wandmontage
Safe and space-Safe and space-saving thanks to the 4-point wall mounting



Trennsteg im Lieferumfang enthalten
Supplied complete with dividers



Geringes Eigengewicht und stabile Bauweise erlauben schwere Beladung mit Traglast bis 15 kg
Low dead weight and stable construction enable heavy loads up to 15 kg



mm



1 VarioPlus DrawBox >W< 20

466250(4)



300 x 80 x 465

2

5

2 VarioPlus DrawBox >C< 40

466260(3)



300 x 155 x 465

2

5

EAN = 4005187 + Art. Nr. ohne führende „4“ + Prüfziffer (X) / EAN = 4005187 + Art. No. without leading “4” + check digit (X)

Schubladen, Trennsteg und Etiketten

Schubladen und Trennsteg aus hochtransparentem Polypropylen und maßgeschneiderte Einstecketiketten sichern bestmögliche Ordnung und Übersicht. Passend für alle Kleinteilemagazine und Depots der Produktlinie >VarioPlus<.

Drawers, dividers and labels

Drawers and dividers made of super transparent polypropylene as well as customised slip-in labels ensure perfect order and clarity. Suitable for all >VarioPlus< small parts cabinets and depots.



Einschubfach für Einstecketikett an der Griffmulde
Pocket for slip-in label in the recessed grip

Schwalbenschwanzführung für Trennsteg
Dovetail guides support dividers

Download Einstecketiketten
Download labels

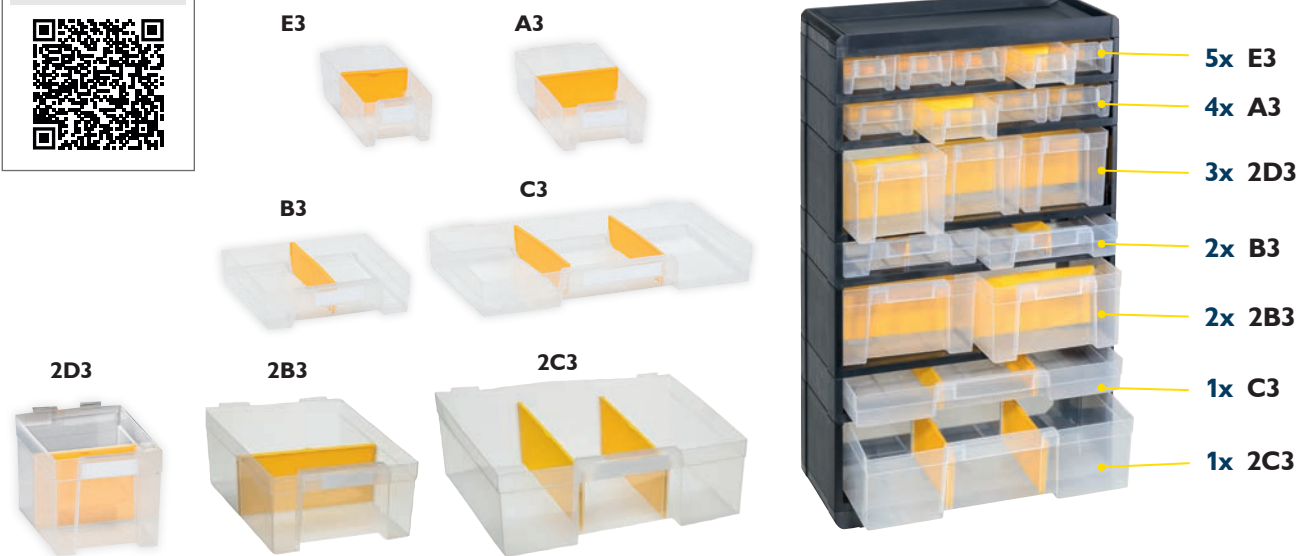

1* **2*** **3*** **4*** **5*** **6*** **7***

Schubladen / Drawers	E3	A3	B3	C3	2D3	2B3	2C3
Außenmaße** (B x T x H) mm / Outside dim. (W x D x H) mm	55 x 130 x 38	69 x 130 x 38	140 x 130 x 38	280 x 130 x 38	92 x 130 x 85	140 x 130 x 85	280 x 130 x 85
Nutzmaße (B x T x H) mm / Usable dim. (W x D x H) mm	45 x 105 x 32	60 x 105 x 32	135 x 105 x 32	275 x 105 x 32	81 x 105 x 79	130 x 105 x 79	270 x 105 x 79
VE / PU	90	72	36	18	27	18	9
Art. Nr. (EAN)/Farbe <input type="checkbox"/> / Art. No. (EAN)/Colour <input type="checkbox"/>	455610(0)	455611(7)	455612(4)	455613(1)	455614(8)	455615(5)	455616(2)
Lieferzeit Tage / Delivery time (days)	5	5	5	5	5	5	5
Trennsteg / Dividers	E3	A3	B3	C3	2D3	2B3	2C3
VE ¹⁾ / PU ¹⁾	1(10)	1(10)	1(5)	1(5)	1(1)	1(1)	1(1)
Art. Nr. (EAN)/Farbe <input type="checkbox"/> / Art. No. (EAN)/Colour <input type="checkbox"/>	455533(2)	455534(9)	455535(6)	455535(6)	455538(7)	455537(0)	455536(3)
Lieferzeit Tage / Delivery time (days)	5	5	5	5	5	5	5
Einstecketiketten auf Bogen / Slip-in labels on a sheet	Als Downloadvorlage erhältlich. Besuchen Sie unsere Website (www.allit.de) / Available as a download template – please feel free to visit our website (www.allit.de/en)						

EAN = 4005187 + Art. Nr. ohne führende „4“ + Prüfziffer (X) / EAN = 4005187 + Art. No. without leading “4” + check digit (X)

¹⁾ Angaben in Klammern = Packungsinhalt (Stück) / ¹⁾ information in brackets = quantity per pack (pieces)

* keine Barcodeauszeichnung / no barcode labeling

** Maße ohne Aushebesicherung / dimensions without lifting protection

Anzahl und Maße der Schubladen und Trennsteg

Die mitgelieferte Bestückung der Kleinteilemagazine und -depots VarioPlus Basic, Basic >D<, Metall & Depot >M< können dieser Tabelle entnommen werden.

Number and dimensions of drawers and dividers

The supplied equipment of the small parts cabinets and depots VarioPlus Basic, Basic >D<, Metal & Depot >M< can be taken from this table.

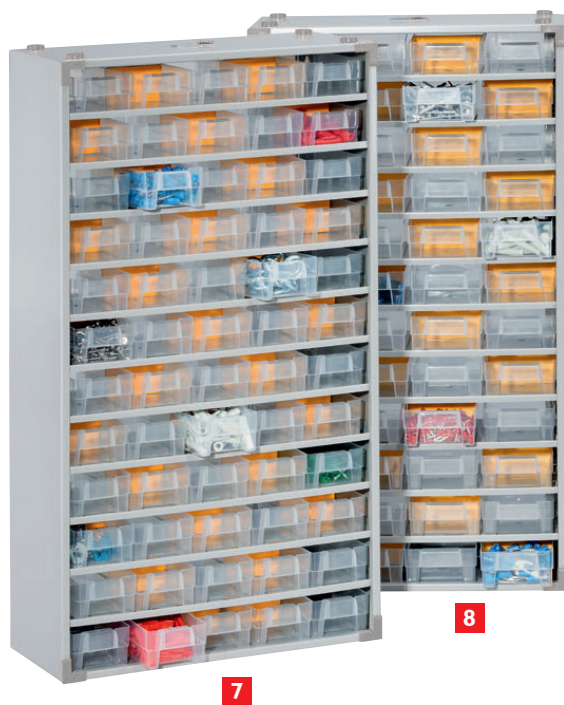

	Artikel/ Article	E3		A3		B3		C3		2D3		2B3		2C3		ProfiPlus Box 2B	
1	VarioPlus Basic 15 (9+6)			8	5			1	1								
2	VarioPlus Basic 32 (21+11)			20	10			1	1								
3	VarioPlus Basic >D< 21 (14+7)					10	5									4	2
4	VarioPlus Basic >D< 34 (20+14)					4	2									4	2
5	VarioPlus Basic 47 (29+18)					4	2	1	1								
6	VarioPlus Basic 54 (33+21)							1	1								
7	VarioPlus Metall 73 (48+25)			48	25												
8	VarioPlus Metall 90 (60+30)	60	30														
9	VarioPlus Depot >M< 40 (19+21)	5	5	4	5					3	3	2	2	1	2	4	4
10	VarioPlus Depot >M< 52 (36+16)	30	10			4	2							2	4		

EAN = 4005187 + Art. Nr. ohne führende „4“ + Prüfziffer (X) / EAN = 4005187 + Art. No. without leading “4” + check digit (X)

Ein umfangreiches Produktprogramm bestehend aus zahlreichen Größen, Farben und Zubehörartikeln für die Betriebs- und Lagereinrichtung.

A comprehensive range of products coming in many sizes and colours, and available with a wide variety of smart accessories benefiting shop floor and warehouse facilities.

ProfiPlus Box

110



ProfiPlus Set

112

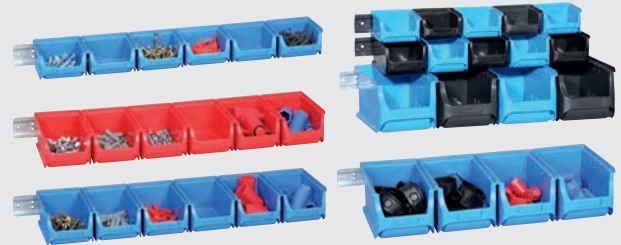

ProfiPlus Depot

114



ProfiPlus Cabinet 70 & 100

120



ProfiPlus Compact

124



ProfiPlus Set

126



ProfiPlus Box oder / or Compact

127

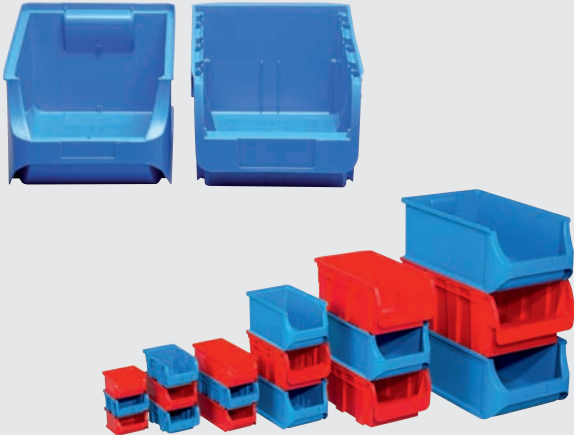

ProfiPlus Shelfbox & Shelfbox »E«

128/130



StorePlus Flex M

131

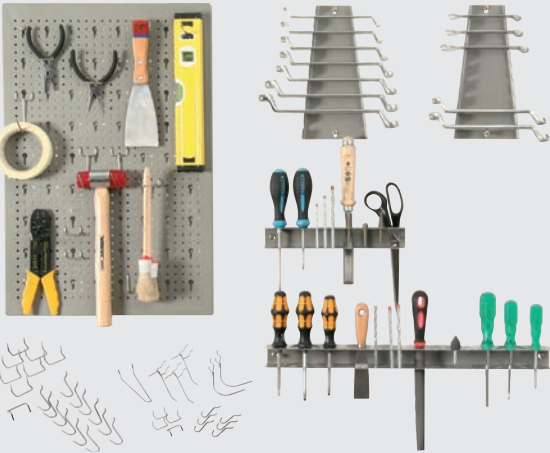

StorePlus Flex »P«
ProfiPlus Endless

132

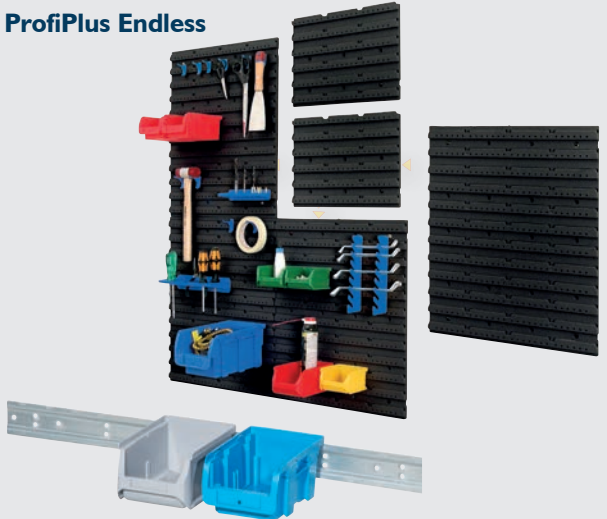

StorePlus Set »P« 55

133

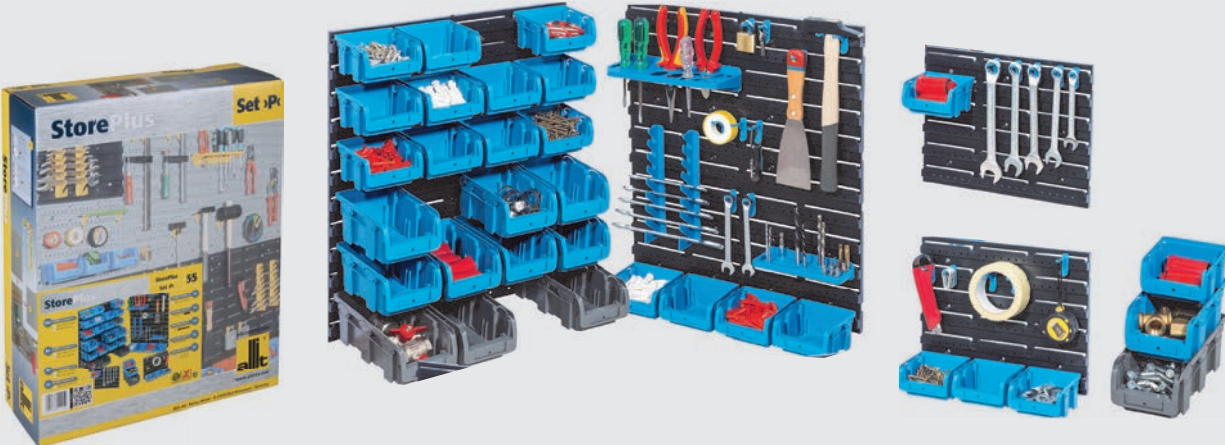

Zertifizierte Kunststoff-Stapelsichtboxen

Hohlkammerprofile am Eingriff sorgen für Formstabilität der temperaturbeständigen Box (-10/+60°C). Durch einen umlaufenden Stapelrand und durchgehende Führungsschienen ist eine sichere Stapelung gewährleistet. Sinnvolle Zubehörteile ermöglichen den variablen und vielfältigen Einsatz dieses Systems.

Certified plastic stackable storage bins

Hollow chamber-profiled grip for optimum dimensional stability (in a temp. range from -10 °C to +60 °C). Safe and secure piling thanks to the circumferential stacking rim and the continuous guide rail. Useful accessory items facilitate the variable and diverse use of this system.



Aufhängeleiste an der Rückseite (bis Größe 3)
Suspension bar on the rear of the bin (up to size 3)



Geeignet für Rollbänder durch glatten Unterboden
Suitable for conveyor belts due to smooth bottom



Umfangreiches Zubehör, individuelle Ausstattung
Wide range of accessories for customised organisation



Vielseitig Passend für Wandsysteme
Suitable for wall-mounted systems



Stapelkompatibel zu ProfiPlus Compact (siehe S.124) und weiteren üblichen Boxen

Stackable with ProfiPlus Compact Box (see p.124) and other boxes



www.tuv.com
ID 1111220546



54
VARIANTEN
9 BOXEN IN 6 FARBEN

54 variants
9 Boxes in 6 colours



	Blue	Red	Yellow	Green	Grey	White	mm	mm	kg	kg		
1 ProfiPlus Box 1	456200(2)	456201(9)	456202(6)	456203(3)	456221(7)	456260(6)	102 x 100 x 60	82 x 74 x 45	2/6	2	30	5
2 ProfiPlus Box 2	456204(0)	456205(7)	456206(4)	456207(1)	456222(4)	456261(6)	102 x 160 x 75	82 x 130 x 60	3/9	3	24	5
3 ProfiPlus Box 2L	456230(9)	456231(6)	456232(3)	456233(0)	456234(7)	456235(4)	102 x 215 x 75	82 x 185 x 60	3/9	3	20	5
4 ProfiPlus Box 2B	456240(8)	456241(5)	456242(2)	456243(9)	456244(6)	456245(3)*	137 x 160 x 82	120 x 125 x 65	3/9	3	20	5
5 ProfiPlus Box 3	456208(8)	456209(5)	456210(1)	456211(8)	456223(1)	456262(0)	150 x 235 x 125	120 x 190 x 105	10/40	10	24	5
6 ProfiPlus Box 3L	456290(3)	456291(0)	456292(7)	456293(4)	456294(1)	456295(8)*	150 x 320 x 125	120 x 275 x 105	15/60	10	18	5
7 ProfiPlus Box 4	456212(5)	456213(2)	456214(9)	456215(6)	456224(8)	456263(7)*	205 x 355 x 150	175 x 265 x 125	25/100	-	12	5
8 ProfiPlus Box 4H	456280(4)	456281(1)	456282(8)	456283(5)	456284(2)	456285(9)*	205 x 355 x 200	175 x 265 x 165	30/90	-	8	5
9 ProfiPlus Box 5	456216(3)	456217(0)	456218(7)	456219(4)	456225(5)	456264(4)*	310 x 500 x 200	275 x 390 x 165	35/140	-	6	5

EAN = 4005187 + Art. Nr. ohne führende „4“ + Prüfziffer (X) / EAN = 4005187 + Art. No. without leading “4” + check digit (X)

* Ohne TÜV-Zertifikat / * Without TÜV certificate



Papier, PE-Schutzfolie / Paper, PE-protective film

Maßgeschneidertes Zubehör

Je nach Einsatzzweck und Größe lassen sich die Stapelsichtboxen ProfiPlus Box individuell mit nützlichem Zubehör ausstatten.

Made-to-measure accessories

Depending on the type of use and size, the storage bins ProfiPlus Box can be customised with useful accessories.



Passende Trennstegvorrichtung vorhanden
Matching divider device available



Einsteiketicket plus Schutzfolie
Slip-in label with protective film



Teilung 2, 2L, 3 und 3L quer; 2B, 4 und 5 längs
Dividers 2, 2L and 3 crosswise up; 2B, 4 and 5 lengthwise



Lieferbar für Stapelsichtboxen Gr. 4, 4H und 5
Carrying bars for storage bin sizes 4 & 5

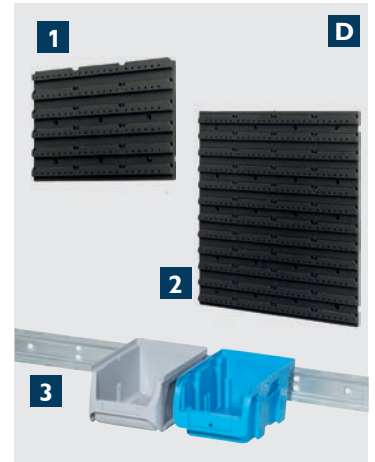
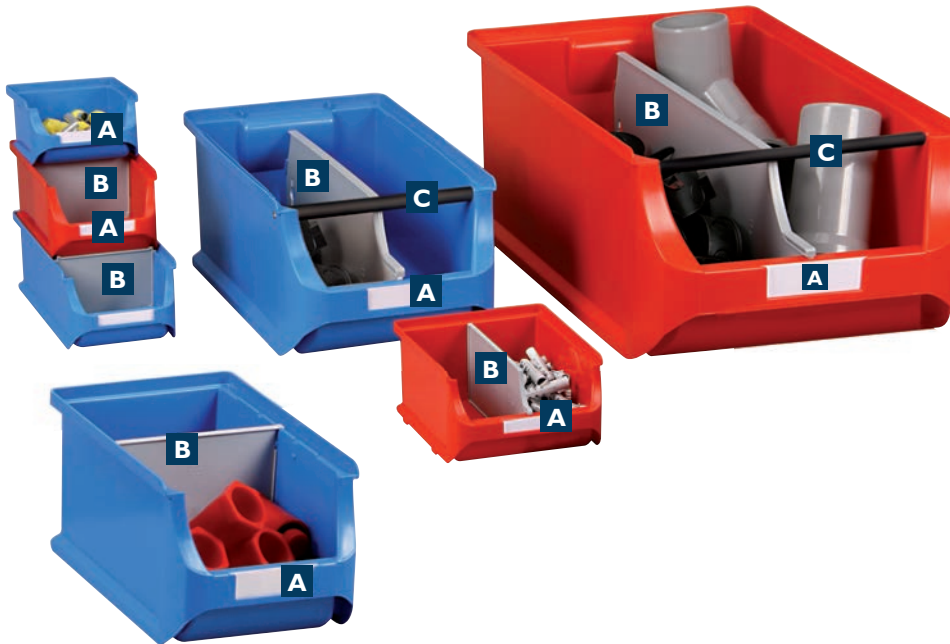

Für Wandhalterung geeignet
Suitable for wallmount,

A	Einsteiketiketten / Labels			
	ProfiPlus Box 1	455705(3)	1(20)	5
	ProfiPlus Box 2	455705(3)	1(20)	5
	ProfiPlus Box 2L	455705(3)	1(20)	5
	ProfiPlus Box 2B	455705(3)	1(20)	5
	ProfiPlus Box 3	455706(0)	1(20)	5
	ProfiPlus Box 3L	455706(0)	1(20)	5
	ProfiPlus Box 4	455707(7)	1(20)	5
	ProfiPlus Box 4H	455707(7)	1(20)	5
	ProfiPlus Box 5	455708(4)	1(20)	5

B	Trennsteg / Divider			
	ProfiPlus Box 1	-	-	-
	ProfiPlus Box 2	455540(0)	1(4)	5
	ProfiPlus Box 2L	455540(0)	1(4)	5
	ProfiPlus Box 2B	455544(8)	1(4)	5
	ProfiPlus Box 3	455541(7)	1(4)	5
	ProfiPlus Box 3L	455541(7)	1(4)	5
	ProfiPlus Box 4	455542(4)	1(1)	5
	ProfiPlus Box 4H	-	-	-
	ProfiPlus Box 5	455543(1)	1(1)	5

C	Tragestange / Carrying bar			
	ProfiPlus Box 4	456180(7)	1(1)	5
	ProfiPlus Box 4H	456180(7)	1(1)	5
	ProfiPlus Box 5	456181(4)	1(1)	5

D	Wandhalterung / Wallmounts			
	1 ProfiPlus Endless 27	457080(9)	6	5
	2 ProfiPlus Endless 54	457090(8)	6	5
	3 ProfiPlus Endless 59	457082(3)	10	5

EAN = 4005187 + Art. Nr. ohne führende „4“ + Prüfziffer (X) / EAN = 4005187 + Art. No. without leading “4” + check digit (X)

1) Angaben in Klammern = Packungsinhalt (Stück) / 1) information in brackets = quantity per pack (pieces)

Stapelsichtboxen-Sets mit Metall-Wandschiene

Robuste Sets zur Organisation von Kleinteilen: Die schnelle Montage und hohe Belastbarkeit zeichnen diese bewährten Lösungen für Ordnung und Übersicht in der Werkstatt aus.

Stackable storage bin sets with metal wall rail

Sturdy sets for organising small parts: Quick installation and high load capacity are the distinguishing features of these proven solutions for tidiness and overview in the workshop.



Sichtboxen durch einfaches Einhängen platzierbar

Simply hook the storage bins to the rail



Sets mit Wandschiene aus Metall

Sets with metal wall rail



	EAN	Color	Dimensions (mm)	Stacking	Truck
1 ProfiPlus Set 1/7	457052(6)	Blue	615 x 100 x 60	20	5
2 ProfiPlus Set 2/7	457060(1)	Red	615 x 165 x 75	10	5
3 ProfiPlus Set 2/7	457062(5)	Blue	615 x 165 x 75	10	5
4 ProfiPlus Set 3/5	457072(4)	Blue	595 x 240 x 125	4	5
5 ProfiPlus Set 1+2+3/17	457135(6)	Blue/Black	595 x 240 x 130	4	5

EAN = 4005187 + Art. Nr. ohne führende „4“ + Prüzfiffer (X) / EAN = 4005187 + Art. No. without leading “4” + check digit (X)

ProfiPlus Box ist TÜV-zertifiziert

Der TÜV hat die Herstellerangaben für die Stapelsichtboxen ProfiPlus Box auf Grundlage des Produktsicherheitsgesetzes (ProdSG) überprüft. Die Stapelsichtboxen sind in allen Größen vom TÜV zertifiziert worden. Getestete Kriterien waren im Einzelnen (1-5):



ProfiPlus Box has been awarded with TÜV certification

The TÜV organisation (a renowned independent safety testing laboratory headquartered in Germany) has validated the manufacturer's specifications relating to open-fronted stackable storage bins ProfiPlus Box for compliance with the provisions of the German Product Safety Act (ProdSG). As a result, all storage bin sizes of the ProfiPlus Box range have achieved TÜV certification. The following parameters were taken into account in the validation process (1-5):

1 Gesicherte Aufhängung

Kleine, in die Wandschiene eingestanzte und nach vorne gebogene „Nasen“ sichern die Boxen mit Klemmwirkung gegen unbeabsichtigtes Ausheben nach oben. Kennzeichnung der Produkte durch unverlierbare Prägung am Boxenboden.

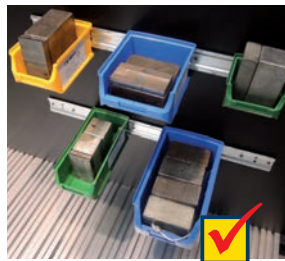

Secured suspension / Safety

Small-sized, forward-protruding lugs stamped into the wall mounting rail interlock with the bins, thus producing a clamping effect which reliably protects the bins against inadvertent detachment.

2 Festigkeit

Mit dem 1,5-fachen der vom Hersteller angegebenen Nennlast befüllt, zeigten die Stapelsichtboxen einzeln stehend, hängend und gestapelt keine wesentliche Verformung. Auch bei einem Falltest der mit Nennlast gefüllten Boxen auf Beton entsteht kein Bruch oder eine bleibende Verformung.

Mechanical strength

Loaded with 1.5 times the nominal load indicated by the manufacturer, the boxes did not exhibit any major deformation, neither while individually standing or suspended, nor while stacked. The boxes also withstood a drop test involving multiple drops onto a concrete floor – without exhibiting any breakage or permanent deformation.

3 Materialveränderung

Bei Temperaturen von -10°C, bei Raumtemperatur und bei +60°C, befüllt mit dem 1,5-fachen der Nennlast, zeigte sich in allen drei Tests (stehend, hängend, gestapelt) keine wesentliche Maßänderung oder gar bleibende Verformung.

Material changes

When subjected to room temperatures of -10 °C and +60 °C, the boxes, loaded with 1.5 times the nominal load indicated by the manufacturer, did not exhibit any major deformation – neither while standing or suspended individually, nor while stacked.

4 Standsicherheit

Der Boxenstapel steht bei zulässiger Stapelhöhe und Beladung jeder Box mit der Nennlast fest, selbst bei einer Position auf einer schiefen Ebene um 5° in Längs- und Querrichtung.

Stacking stability

A stack of boxes, piled up to the maximum allowable height and loaded with the nominal load, will remain stable even if placed on a plane inclined by 5° in longitudinal or lateral direction.



5 Schlagfestigkeit

Bei Prüfung der Schlagfestigkeit mit einem Federhammer entsteht im Boden bzw. am oberen Rand kein Bruch oder eine bleibende Verformung.



Impact resistance

In the spring hammer impact resistance test, neither the base nor the rim of the boxes exhibited any breakage or permanent deformation.

Fertig bestückte Komplettsysteme

Die robusten Wand-, Ständer- und Fahrregale komplett bestückt mit gängigen Boxenkombinationen für den professionellen Einsatzbereich. Einen Artikel bestellen – die komplette Lösung erhalten.

Fully equipped systems

Robust wall racks, free-standing stationary racks and mobile racks – fully equipped with the most popular bin assortments designed for use in professional environments. Order one item – get the perfectly integrated solution!



Individuelle Bestückung (siehe S. 116)
Customised equipment (see p. 116)

ProfiPlus Depot ›WN‹ 49

Wandregal, niedrig, bestückt mit 49 Stapelsichtboxen ProfiPlus Box

ProfiPlus Depot ›WN‹ 49

Wall rack, low model, equipped with 49 open-fronted stackable storage bins ProfiPlus Box



1*

	20 x ProfiPlus Box 2
	10 x ProfiPlus Box 2L
	14 x ProfiPlus Box 3
	5 x ProfiPlus Box 4

ProfiPlus Depot ›SHS‹ 113

Ständerregal, hoch, einseitig bestückt mit 113 Stapelsichtboxen ProfiPlus Box

ProfiPlus Depot ›SHS‹ 113

Free-standing stationary rack, high model, single-sided, equipped with 113 open-fronted stackable storage bins ProfiPlus Box



2*

	30 x ProfiPlus Box 1
	30 x ProfiPlus Box 2
	20 x ProfiPlus Box 2L
	28 x ProfiPlus Box 3
	5 x ProfiPlus Box 4



mm



1 ProfiPlus Depot ›WN‹ 49

2 ProfiPlus Depot ›SHS‹ 113

455935(4)		1130 x 370 x 1050	1	21
455900(2)		1130 x 500 x 1900	1	21

EAN = 4005187 + Art. Nr. ohne führende „4“ + Prüfziffer (X) / EAN = 4005187 + Art. No. without leading “4” + check digit (X)



* keine Wiederverkaufsverpackung/Barcode-Auszeichnung / contains no barcode



Metall / Metal



Fahrbar durch je
2 Lenk- & Bockrollen

Mobile thanks to 2 swivel
castors and 2 fixed
castors

ProfiPlus Depot ›RND‹ 128

Fahrregal, niedrig, beidseitig bestückt mit
128 Stapelsichtboxen ProfiPlus Box

ProfiPlus Depot ›RND‹ 128

Mobile rack, low model, double-sided, equipped
with 128 open-fronted stackable storage bins
ProfiPlus Box



3*

- 40 x ProfiPlus Box 1
- 40 x ProfiPlus Box 2
- 20 x ProfiPlus Box 2L
- 28 x ProfiPlus Box 3

ProfiPlus Depot ›RHD‹ 226

Fahrregal, hoch, beidseitig bestückt mit 226 Stapel-
sichtboxen ProfiPlus Box

ProfiPlus Depot ›RHD‹ 226

Mobile rack, high model, double-sided, equipped
with 226 open-fronted stackable storage bins
ProfiPlus Box

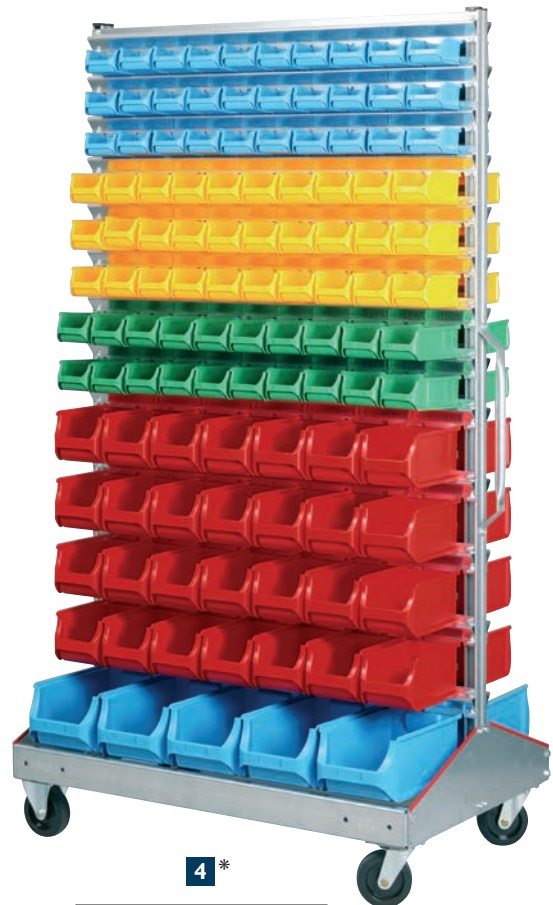

4*

- 60 x ProfiPlus Box 1
- 60 x ProfiPlus Box 2
- 40 x ProfiPlus Box 2L
- 56 x ProfiPlus Box 3
- 10 x ProfiPlus Box 4



mm



3 ProfiPlus Depot ›RND‹ 128

4 ProfiPlus Depot ›RHD‹ 226

455925(5)		1200 x 720 x 1160	1	21
455920(0)		1200 x 730 x 2040	1	21

EAN = 4005187 + Art. Nr. ohne führende „4“ + Prüfziffer (X) / EAN = 4005187 + Art. No. without leading “4” + check digit (X)



* keine Wiederverkaufsverpackung/Barcode-Auszeichnung / contains no barcode

Vielfalt nach Maß – individuelle Bestückung – grenzenlose Möglichkeiten

Tailor-made variety – custom configuration – endless possibilities

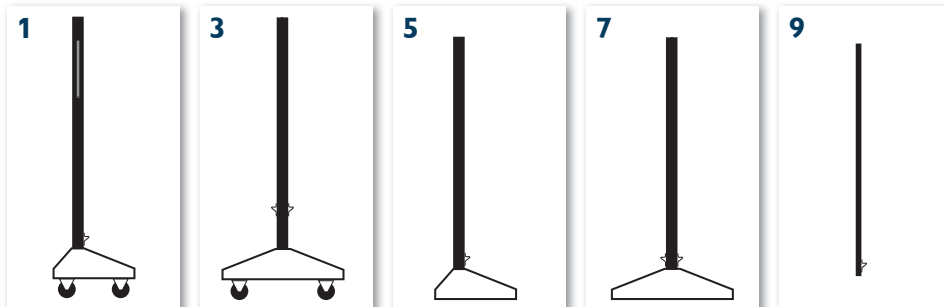

1
RNS
Fahrregal, niedrig,
1-seitig bestückbar
Mobile rack, low,
for single-sided use

3
RND
Fahrregal, niedrig,
2-seitig bestückbar
Mobile rack, low,
for double-sided
use

5
SNS
Ständerregal,
niedrig, 1-seitig
bestückbar
Free-standing
stationary rack,
low, for single-
sided use

7
SND
Ständerregal,
niedrig, 2-seitig
bestückbar
Free-standing
stationary rack,
low, for double-
sided use

9
WN
Wandregal, niedrig,
1-seitig bestückbar
Wall rack, low, for
single-sided use

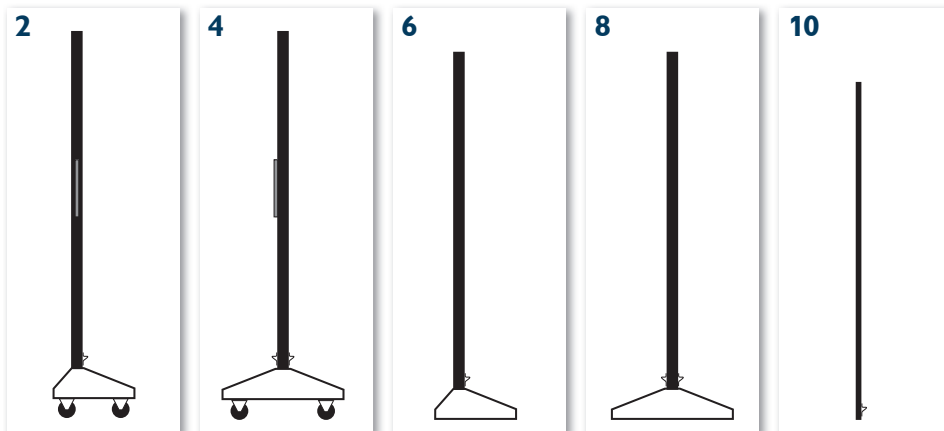

2
RHS
Fahrregal, hoch,
1-seitig bestückbar
Mobile rack, high,
for single-sided use

4
RHD
Fahrregal, hoch,
2-seitig bestückbar
Mobile rack, high,
for double-sided
use

6
SHS
Ständerregal, hoch,
1-seitig bestückbar
Free-standing
stationary rack,
high, for single-
sided use

8
SHD
Ständerregal, hoch,
2-seitig bestückbar
Free-standing
stationary rack,
high, for double-
sided use

10
WH
Wandregal, hoch,
1-seitig bestückbar
Wall rack, high,
for single-sided use

In 3 Schritten zur maßgeschneiderten Lösung!

Three steps to a tailor-made solution!

- 1. Grundform wählen**
Choose your desired basic model
- 2. Bestückung festlegen**
Select bin types
- 3. Anzahl Stapelsichtboxen und Schienen ermitteln**
Determine the required number of bins and rails

Schritt 1 / Step 1

- Aus Regal 1 - 10 wählen.
Choose from shelf type 1 - 10.
- Technische Angaben zu den Regalen siehe Tabelle unten.
For technical details on the rack models, please refer to the table below.

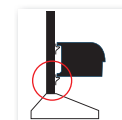

Wichtig: Alle Gestelle werden mit einer Grundschiene ausgeliefert, in die keine Boxen eingehängt werden können. Sie dient lediglich als Anlage für die unterste Boxenreihe.

Important: All racks are supplied with a base rail which is, however, not designed to accommodate bins. It merely serves as a support surface for the lowermost row of bins.

Important: All racks are supplied with a base rail which is, however, not designed to accommodate bins. It merely serves as a support surface for the lowermost row of bins.



mm



Art. Nr.	EAN	Abmessungen (mm)	Boxen	Schienen
1 ProfiPlus Depot >RNS<	455975(0)	1200 × 500 × 1160	1	21
2 ProfiPlus Depot >RHS<	455974(3)	1200 × 500 × 2040	1	21
3 ProfiPlus Depot >RND<	455977(4)	1200 × 715 × 1160	1	21
4 ProfiPlus Depot >RHD<	455976(7)	1200 × 715 × 2040	1	21
5 ProfiPlus Depot >SNS<	455971(2)	1130 × 500 × 1020	1	21
6 ProfiPlus Depot >SHS<	455970(5)	1130 × 500 × 1900	1	21
7 ProfiPlus Depot >SND<	455973(6)	1130 × 700 × 1020	1	21
8 ProfiPlus Depot >SHD<	455972(9)	1130 × 700 × 1900	1	21
9 ProfiPlus Depot >WN<	455979(8)	1130 × 50 × 1010	1	21
10 ProfiPlus Depot >WH<	455978(1)	1130 × 50 × 1890	1	21

EAN = 4005187 + Art. Nr. ohne führende „4“ + Prüfziffer (X) / EAN = 4005187 + Art. No. without leading “4” + check digit (X)



* keine Wiederverkaufsverpackung/Barcode-Auszeichnung / contains no barcode



Metall / Metal

ProfiPlus Depot ›WN‹ Wandregal, niedrig, einseitig bestückbar

ProfiPlus Depot ›WN‹ Wall rack, low model, for single-sided use

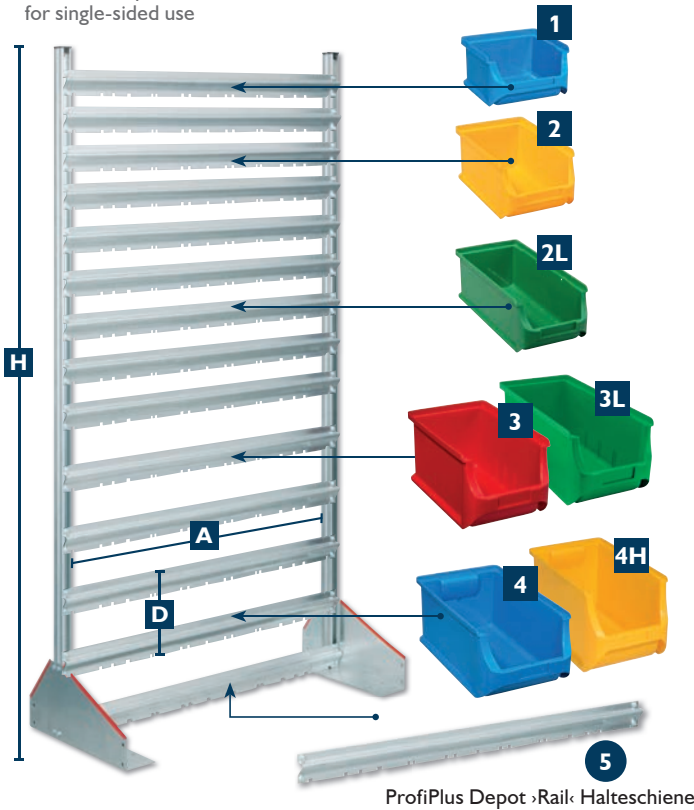

Schritt 2 / Step 2

- Bestückung des Regals mit Stapelsichtboxen festlegen
Boxengröße und -farbe Reihe für Reihe festlegen, bis die Gesamthöhe (H) der Regalvariante erreicht ist.
Von unten nach oben vorgehen, z.B. die größten Boxen unten, die kleinsten oben.
Platzverbrauch je Boxenreihe in der Höhe (D) und Anzahl der Boxen je Reihe (A) siehe Tabelle unten.

Select bin types for racks

- Choose the size and colour of the bins row by row until the total height (H) of the selected rack model is reached.
Proceed from the bottom to the top; choose the largest bins for the lower rack area, the smallest ones for the upper area.
The space requirement per row in terms of height (D) and number of bins per row (A) is provided in the table below.

Schritt 3 / Step 3

Anzahl Stapelsichtboxen und Halteschienen ermitteln

- Vorgehensweise siehe Beispielrechnung
Anzahl Schienen = Anzahl Boxenreihen
Je Boxenreihe ist nur eine Farbe möglich
Bestelldaten für Sichtboxen siehe S. 110 (ProfiPlus Box)

Determine the required number of bins and rails

- For details on the procedure, please refer to the example calculation
Number of rails = Number of bin rows
Only one bin colour can be selected per row
For ordering data relating to storage bins, please see p. 110 (ProfiPlus Box)

Table with 7 columns: Bestückung / Assembly, Stück je Reihe / Bins per row, Einbauhöhe je Reihe / Height per row, mm, EAN, and a truck icon. Rows include Box 1, Box 2, Box 2L, Box 3, Box 3L, Box 4, Box 4H, and Halteschiene 5.

ProfiPlus Depot ›WN‹ Wandregal, niedrig, einseitig bestückbar
ProfiPlus Depot ›WN‹ Wall rack, low model, for single-sided use



Musterberechnung niedrige Version / Example calculation lower version

Table for example calculation showing Max. Bestückungshöhe / Max. usable height (910 mm) and Schienen / Rails (6 x). Includes rows for different bin types and a total sum.

EAN = 4005187 + Art. Nr. ohne führende „4“ + Prüfziffer (X) / EAN = 4005187 + Art. No. without leading “4” + check digit (X)

Bestückte Fahrregale für den professionellen Einsatz

Die robusten Fahrregale komplett bestückt mit Lagersichtboxen oder in Kombination mit unterschiedlichen Kleinteilemagazinen bieten Raum für großzügige Unterbringung im professionellen Einsatzbereich. Die Komplettlösung für Aufbewahrung unterschiedlichster Teile.

Equipped mobile shelving for professional use

The robust mobile shelving, fully equipped with storage boxes or in combination with various small parts magazines, offers space for generous storage in professional applications. The all-in-one solution for storing a wide variety of parts.

ProfiPlus Depot >RD< 190

Kombi-Fahrregal, bestückt mit 24 Stapelsichtboxen ProfiPlus Box Größe 3, zwei Kleinteilemagazinen VarioPlus Pro und zwei Klappschütten VarioPlus ProFlip

ProfiPlus Depot >RD< 190

Combination mobile shelving, equipped with 24 stackable boxes ProfiPlus Box size 3, two small parts magazines VarioPlus Pro and two folding chutes VarioPlus ProFlip

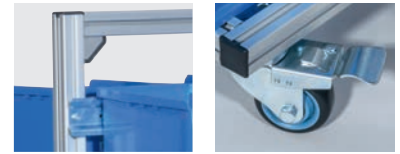

An der Schiene können Lagersichtboxen (Größe 1-3) problemlos ein- und abgehängt werden
Storage boxes (size 1-3) can be easily attached and detached from the rail

4 kugelgelagerte Lenkrollen, 2 mit Feststellbremsen
4 swivel castors with ball bearings, 2 with parking brakes

ProfiPlus Depot >RD< 48

Kombi-Fahrregal, bestückt mit 48 Stapelsichtboxen ProfiPlus Box Größe 3

ProfiPlus Depot >RD< 48

Combination mobile shelving, equipped with 48 ProfiPlus Box size 3 stackable storage boxes



1 *

- 24 x ProfiPlus Box 3
- 1 x VarioPlus Pro 53/60
- 1 x VarioPlus Pro 53/100
- 1 x VarioPlus ProFlip 4
- 1 x VarioPlus ProFlip 2

2 *

- 48 x ProfiPlus Box 3

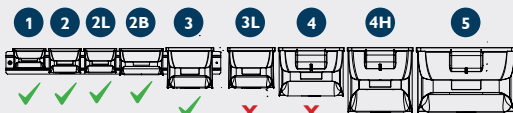
Schienen sind für folgende ProfiPlus Boxen geeignet:
Rails are suitable for the following ProfiPlus boxes:



mm

1 ProfiPlus Depot >RD< 190

455960(6)



710 x 585 x 1335

1

5

2 ProfiPlus Depot >RD< 48

455965(1)



710 x 505 x 1335

1

5

EAN = 4005187 + Art. Nr. ohne führende „4“ + Prüzfiffer (X) / EAN = 4005187 + Art. No. without leading “4” + check digit (X)



* keine Wiederverkaufsverpackung/Barcode-Auszeichnung / contains no barcode



Aluminium / Aluminium



Individuell bestückbares Fahrregal – für jedes Teil den richtigen Aufbewahrungsort

Die bestückten Kombinationen der Fahrregale passen noch nicht ganz? Durch den individuellen Zusammenbau des Fahrregals sind die unterschiedlichsten Varianten an Fahrregalen möglich. Die Metallschienen werden je nach Anbringung der jeweiligen Bestückung an das Fahrregal angebracht. So kann ein einzigartiger Lagerplatz, auch für das letzte Teil entstehen.

Individually equippable mobile shelving – the right one for every part location

The equipped combinations of mobile shelving don't quite fit yet? Through the individual assembly of the mobile rack are very different Variants on mobile shelves possible. The metal rails are attached to the mobile shelving depending on the attachment of the respective equipment. So can one unique storage space, also for the last part.



An der Schiene können Lagersichtboxen (Größe 1-3) problemlos ein- und abgehängt werden
Storage boxes (size 1-3) can be easily attached and detached from the rail



4 kugelgelagerte Lenkrollen, 2 mit Feststellbremsen
4 swivel castors with ball bearings, 2 with parking brakes

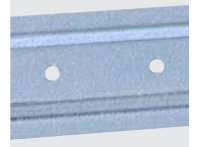

Die Bohrungen an der Schiene sorgen für leichtes anbringen von Kleinteilemagazinen oder Klappschütten
The holes on the rail ensure easy attachment of small parts magazines or folding chutes



Durch individuelle Anbringung der Schienen sind die unterschiedlichsten Varianten an Fahrregalen möglich.
By individually attaching the rails, a wide variety of mobile shelving variants are possible.

Schienen sind für folgende ProfiPlus Boxen geeignet:
Rails are suitable for the following ProfiPlus boxes:



3 ProfiPlus Depot >RD<

4 ProfiPlus Depot Rail 67

455982(8)		710 x 420 x 1335	1	5
455914(9)		665 x 5,5 x 46,8	6	5

EAN = 4005187 + Art. Nr. ohne führende „4“ + Prüfziffer (X) / EAN = 4005187 + Art. No. without leading “4” + check digit (X)

* keine Wiederverkaufsverpackung/Barcode-Auszeichnung / contains no barcode

70 cm breiter Multifunktions-Schrank aus Stahlblech

Der Universal-Stahl-Flügeltürenschränk ist abschließbar und ein „Must-have“ für Lager und Werkstatt. Die verstärkten Flügeltüren sorgen für eine hohe Stabilität. Die verzinkten Einlegeböden des Stahlschranks garantieren eine Traglast von je 50 kg und sind im 10 mm-Raster verstellbar.

70 cm wide multifunction cabinet made of sheet steel

This steel wing door cabinet is a keylockable all-rounder and a real “must-have” in the warehouse and workshop. The hinged doors of the cabinet are reinforced for maximum stability. The cabinet’s galvanised shelves, which can hold loads of 50 kg each, are height-adjustable in 10 mm increments.



Sichtlagerkästen in unterschiedlichen Größen, Farben und Bestückungen
Open-front storage bins of different sizes, colours and configurations



Muldengriff für Einhand-Öffnung mit Schloss
Recessed handle for one-hand opening, equipped with a key lock



Für Wandbefestigung vorbereitet
Ready for wall mounting

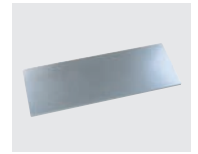

Zusätzliche Einlegeböden als Zubehör verfügbar
Extra shelves are available as accessories



3-Riegel-Verschluss
3-bolt latch





Fachböden sind schnell auf Ihre Wunsch-Höhe einzustellen
Shelves can be quickly adjusted to the desired height





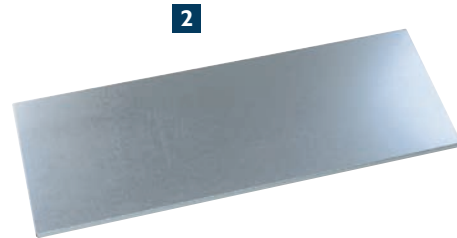

Patentierter Mechanismus: Zum Schließen einfach drücken, auch mit vollen Händen
Patented mechanism: simply press shut to close – even when your hands are full





 24 x ProfiPlus Box 3
 24 x ProfiPlus Box 3





 60 x ProfiPlus Box 2
 24 x ProfiPlus Box 3

 60 x ProfiPlus Box 2
 54 x ProfiPlus Box 2



mm



1	ProfiPlus Cabinet 70/9	455940(8)		700 x 300 x 1980	1	21
2	ProfiPlus Cabinet Shelf 70	455941(5)		695 x 250 x 15	1	21
3	ProfiPlus Cabinet >B< 70/11-48	455945(3)		700 x 300 x 1980	1	21
4	ProfiPlus Cabinet >B< 70/15-84	455946(0)		700 x 300 x 1980	1	21
5	ProfiPlus Cabinet >B<70/18-114	455947(7)		700 x 300 x 1980	1	21

EAN = 4005187 + Art. Nr. ohne führende „4“ + Prüfziffer (X) / EAN = 4005187 + Art. No. without leading “4” + check digit (X)

* RAL Farbton = 7035 / RAL Color = 7035

100 cm breiter Multifunktions-Schrank aus Stahlblech

Der Universal-Stahl-Flügeltürenschrack ist abschließbar und ein „Must-have“ für Lager und Werkstatt. Die verstärkten Flügelüren sorgen für eine hohe Stabilität. Die verzinkten Einlegeböden des Stahlschranks garantieren eine Traglast von je 50 kg und sind in den 10 mm-Raster verstellbar.

100 cm wide multifunction cabinet made of sheet steel

This steel wing door cabinet is a keylockable all-rounder and a real “must-have” in the warehouse and workshop. The hinged doors of the cabinet are reinforced for maximum stability. The cabinet’s galvanised shelves, which can hold loads of 50 kg each, are height-adjustable in 10 mm increments.



Sichtlagerkästen in unterschiedlichen Größen, Farben und Bestückungen
Open-front storage bins of different sizes, colours and configurations



Muldengriff für Einhand-Öffnung mit Schloss
Recessed handle for one-hand opening, equipped with a key lock



Für Wandbefestigung vorbereitet
Ready for wall mounting

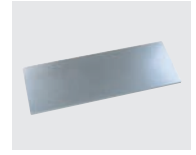

Zusätzliche Einlegeböden als Zubehör verfügbar
Extra shelves are available as accessories



3-Riegel-Verschluss
3-bolt latch



Fachböden sind schnell auf Ihre Wunsch-Höhe einzustellen
Shelves can be quickly adjusted to the desired height



Patentierter Mechanismus: Zum Schließen einfach drücken, auch mit vollen Händen
Patented mechanism: simply press shut to close – even when your hands are full



* RAL Farbton = XX / RAL Color = XX



■ 20 x ProfiPlus Box 4
■ 20 x ProfiPlus Box 4

■ 30 x ProfiPlus Box 3
■ 20 x ProfiPlus Box 4



1	ProfiPlus Cabinet 100/4
2	ProfiPlus Cabinet Shelf 100
3	ProfiPlus Cabinet >B< 100/9-40
4	ProfiPlus Cabinet >B< 100/9-50

455942(2)		1000 x 420 x 1980	1	21
455943(9)		995 x 370 x 24	1	21
455950(7)		1000 x 420 x 1980	1	21
455951(4)		1000 x 420 x 1980	1	21

EAN = 4005187 + Art. Nr. ohne führende „4“ + Prüfziffer (X) / EAN = 4005187 + Art. No. without leading “4” + check digit (X)

Nestbare Kunststoff Stapelsichtbox

Die Stapelsichtbox ist durch die innovative Stapelklappe ineinander nestbar und spart dadurch Kosten beim Transport und im Lager. Die Boxen sind in vier Standardfarben und sechs Größen verfügbar. Zusätzliche Features erhöhen den Nutzwert in der Werkstatt.

Open-fronted stackable plastic storage bins

The stackable storage bins of the ProfiPlus Compact range are equipped with hinged stacking lugs – an innovative feature allowing them to be nested inside each other, thus saving valuable space during transport and storage. The bins come in four different standard colours and six sizes. A smart array of add-on accessories boost the practical value of the bins in work environments.



Nach dem Einrasten der Stapelklappen sind die Boxen stapelbar

After the stacking lugs are locked into place, the bins can be stacked



Stapelkompatibel zur ProfiPlus Box und weiteren üblichen Boxen

Stackable with ProfiPlus Box and other bins of this size



1-4

Vielseitig Passend für Wandsysteme

Suitable for wall-mounted systems



Platzsparend im Regal, Lager und beim Transport

Nestability helps to save space on the shelf, in the warehouse and in transit



5

Kompatibel zu gängigen KFZ-Einrichtungen

Compatible with all common vehicle interiors



mm



mm



kg



1 ProfiPlus Compact 1	456400(6)	456401(3)	456402(0)	456403(7)	456404(4)	456405(1)	102 x 100 x 60	80 x 70 x 45	1/3	18	*
2 ProfiPlus Compact 2	456410(5)	456411(2)	456412(9)	456413(6)	456414(3)	456415(0)	102 x 160 x 75	68 x 135 x 60	2/6	24	*
3 ProfiPlus Compact 2L	456420(4)	456421(1)	456422(8)	456423(5)	456424(2)	456425(9)	102 x 215 x 75	68 x 190 x 60	2/6	20	*
4 ProfiPlus Compact 3	456430(3)	456431(0)	456432(7)	456433(4)	456434(1)	456435(8)	155 x 235 x 125	110 x 190 x 105	5/20	20	*
5 ProfiPlus Compact 4	456440(2)	456441(9)	456442(6)	456443(3)	456444(0)	456445(7)	210 x 350 x 150	170 x 280 x 130	15/60	10	*
6 ProfiPlus Compact 5	456450(1)	456451(8)	456452(5)	456453(2)	456454(9)	456455(6)	315 x 500 x 200	270 x 410 x 180	20/80	5	*

EAN = 4005187 + Art. Nr. ohne führende „4“ + Prüfziffer (X) / EAN = 4005187 + Art. No. without leading “4” + check digit (X)

^{*)} Lieferzeit 5 Tage, ausgenommene Artikel (Fett gekennzeichnet = 60 Tage ab Bestellmenge von 1.000 Stück oder Rahmenvereinbarung) /

^{*)} Delivery time 5 days, excluding articles (marked in bold = 60 days from an order quantity of 1,000 pieces or framework agreement)



Papier, PE-Schutzfolie / Paper, PE-protective film

Platzsparend durch patentiertes Stapelklappen-System!

Die Box spart Platz im Lager und beim Transport. Erst durch das Herausklappen der Stapelklappen sind die Boxen aufeinander stapelbar. Sie lassen sich leicht wieder einklappen - durch diese Mechanik ist die ProfiPlus Compact wieder nestbar und spart bei Nichtbenutzung bis zu 40% Lagervolumen.

Space-saving thanks to patented stacking lug system!

The box makes a great space saver in the warehouse and during transport. The bins are ready for stacking when the stacking lugs are pushed towards the inside of the bin. They can be just as easily pushed back to their original position – this smart mechanism makes the ProfiPlus Compact nestable again and ensures storage space savings of up to 40% when the boxes are not in use.



Stapelklappe im Ruhezustand – Boxen ineinander nestbar

Stacking lugs are in flipped-in position (flush) – the bins are nestable



Zum Aufeinanderstapeln: Stapelklappe aus der Boxenwand lösen

For bin stacking, unlock the stacking lugs from the wall of the bin



Stapelklappe zur Boxenmitte drücken, bis diese einrastet

Push the stacking lugs towards the inside of the bin until they lock in place



Stapelklappe arretiert, Boxen sind aufeinander stapelbar

When all stacking lugs are locked in place, the bins can be stacked upon each other



Um die Boxen wieder ineinander zu stapeln, einfach Stapelklappen zurückdrücken

In order to make the bins nestable again, press the stacking lug back into the side wall











Zubehör für ProfiPlus Compact

Trennsteg, Steck- oder Klappscheiben für Stapelsichtboxen ProfiPlus Compact. Sinnvolle Ausstattungs-Extras, die zusätzlich Ordnung schaffen.

Accessories for ProfiPlus Compact

Dividers, drop-in front windows, hinged front flaps for stackable storage bins ProfiPlus Compact. Useful extra equipment for even better organisation.

A Trennsteg / Divider	   		
	EAN	Length	Height
ProfiPlus Compact 2*	456482(2)	270	5
ProfiPlus Compact 2L*	456482(2)	270	5
ProfiPlus Compact 3*	456483(9)	60	5
ProfiPlus Compact 4*	456484(6)	68	5

B Steck-/Klappscheibe / Shield	   		
	EAN	Length	Height
ProfiPlus Compact 2*	456462(4)	280	5
ProfiPlus Compact 2L*	456462(4)	280	5
ProfiPlus Compact 3*	456463(1)	234	5
ProfiPlus Compact 4*	456464(8)	66	5

EAN = 4005187 + Art. Nr. ohne führende „4“ + Prüfziffer (X) / EAN = 4005187 + Art. No. without leading “4” + check digit (X)

 * keine Barcode-Auszeichnung / contains no barcode

Stapelsichtboxen-Sets mit Kunststoff-Wandschiene oder Wand

Praktische Sets zur Organisation von Kleinteilen: Die schnelle Montage und hohe Belastbarkeit zeichnen diese bewährten Lösungen für Ordnung und Übersicht in der Werkstatt aus.

Stackable storage bin sets with plastic wall rail or wall

Practical sets for organising small parts: Quick installation and high load capacity are the distinguishing features of these proven solutions for tidiness and overview in the workshop.



ProfiPlus Compact (siehe S. 124)

ProfiPlus Compact (see p. 124)



Sichtboxen durch einfaches Einhängen platzierbar

Simply hook the storage bins to the rail

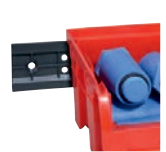

Stabile Kunststoff-schiene

Sturdy plastic rail



mm



1 ProfiPlus Set >C< 1+2/17

2 ProfiPlus Set >C< 2/6

3 ProfiPlus Set >C< 1+2/12

457120(2)		385 x 130 x 340	4	5
457046(5)		510 x 165 x 75	10	5
457048(9)		510 x 165 x 105	8	5

EAN = 4005187 + Art. Nr. ohne führende „4“ + Prüfziffer (X) / EAN = 4005187 + Art. No. without leading “4” + check digit (X)

Welche Stapelsichtbox für welchen Zweck?

Die Entscheidung zwischen den Stapelsichtboxen ProfiPlus Box oder ProfiPlus Compact hängt von verschiedenen Faktoren ab.

When to use ProfiPlus Box when ProfiPlus Compact?

The decision of whether to choose ProfiPlus Box or ProfiPlus Compact storage bins will depend on a variety of aspects.



Mechanische Beanspruchung und Belastung

Die ›ProfiPlus Box‹ hat ein solides Form-design. Der Materialeinsatz ist höher. Die dadurch stabilere Box ist besonders geeignet für Beladung mit schweren Gegenständen. Die ProfiPlus Box ist TÜV-zertifiziert.

Die Variante ›ProfiPlus Compact‹ ist dünnwandiger. Daher ist sie eher für die Beladung mit leichten Gegenständen geeignet.

Mechanical exposure and load capacity

›ProfiPlus Box‹ storage bins are particularly solid, sturdy and dimensionally stable because they consist of more material. This type of bin is especially suited for heavy loads. ProfiPlus Box is TÜV-certified.

Thinner walls and is thus designed for lighter loads.

Einsatz- bzw. Verwendungszweck

Bei gestapeltem Einsatz in großen Stückzahlen, z. B. im eigenen Lager, eignet sich die Box in bestimmten Fällen besser, weil das Handling mit den Stapelklappen (wie bei ›ProfiPlus Compact‹) entfällt.

Durch die Stapelklappen lassen sich die Boxen bis zum eigentlichen Einsatz ineinander stapeln. Das bringt dem Handel beim Transport/Versand, im Lager und im Verkaufsregal Platz- und damit Kostenersparnis.

Fields of use

When many bins need to be stacked, e.g. in your own warehouse, use of this type of bin may sometimes be more economical because handling the hinged stacking lugs (as with ›ProfiPlus Compact‹) is not necessary.

Due to the integrated stacking lugs, the bins can be nested until needed. This saves considerable space during transport and storage as well as on the sales shelf and thus also reduces cost.

Gewünschte Ausstattung

Einstecketiketten und Trennsteg

Einstecketiketten, Trennsteg, Steckscheiben.

Available equipment features

Slip-in labels and dividers

Slip-in labels, dividers, fixed shields.

Zubehör/ Anwendung

Wandbefestigung mit Schiene, Endloswandelement, Tischdrehständer sowie Fahr-, Ständer- und Wandregalen.

Schiene zur Wandbefestigung, Endloswandelement sowie Fahr-, Ständer- und Wandregale.

Accessoires/ application

Wall mounting with rail, infinitely expandable wall panel system as well as mobile, free-standing (stationary) and wall racks.

Rail for wall mounting, infinitely expandable wall panel system as well as mobile, free-standing (stationary) and wall racks.

ProfiPlus Box und Compact sind stapelkompatibel zueinander und zu vielen anderen Boxen

ProfiPlus Box and Compact are stacking compatible with each other and with many other boxes



Industrieboxen in 3 Längen, 2 Breiten und 2 Farben mit zahlreichem Zubehör

Industriequalität für hohe Tragkraft. Aus bruchsicherem, hochbelastbarem Polypropylen. Regalangepasst - spart Lagerraum und sorgt für eine hervorragende Übersicht. Beständig gegen gebräuchliche Säuren und Laugen. Formstabil durch extra dicke Wandung.

Closed-front industrial shelf bins available in 3 lengths, 2 widths and 2 colours, complemented with extensive accessories

Industrial-grade quality for high load capacity. Made of shatter-proof, high-impact polypropylene. Dimensioned to fit perfectly into the shelf – for streamlined storage space and perfect visibility of stored items. Resistant to most common acids and alkalis. Dimensionally stable thanks to the extra thick wall design.



Verbesserte Aufnahme von Kleinteilen dank Noppen am Boxenboden

Knobbed bottom for convenient picking of small parts

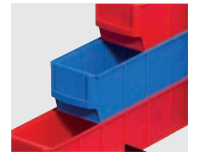

Stapelbar
Stackable

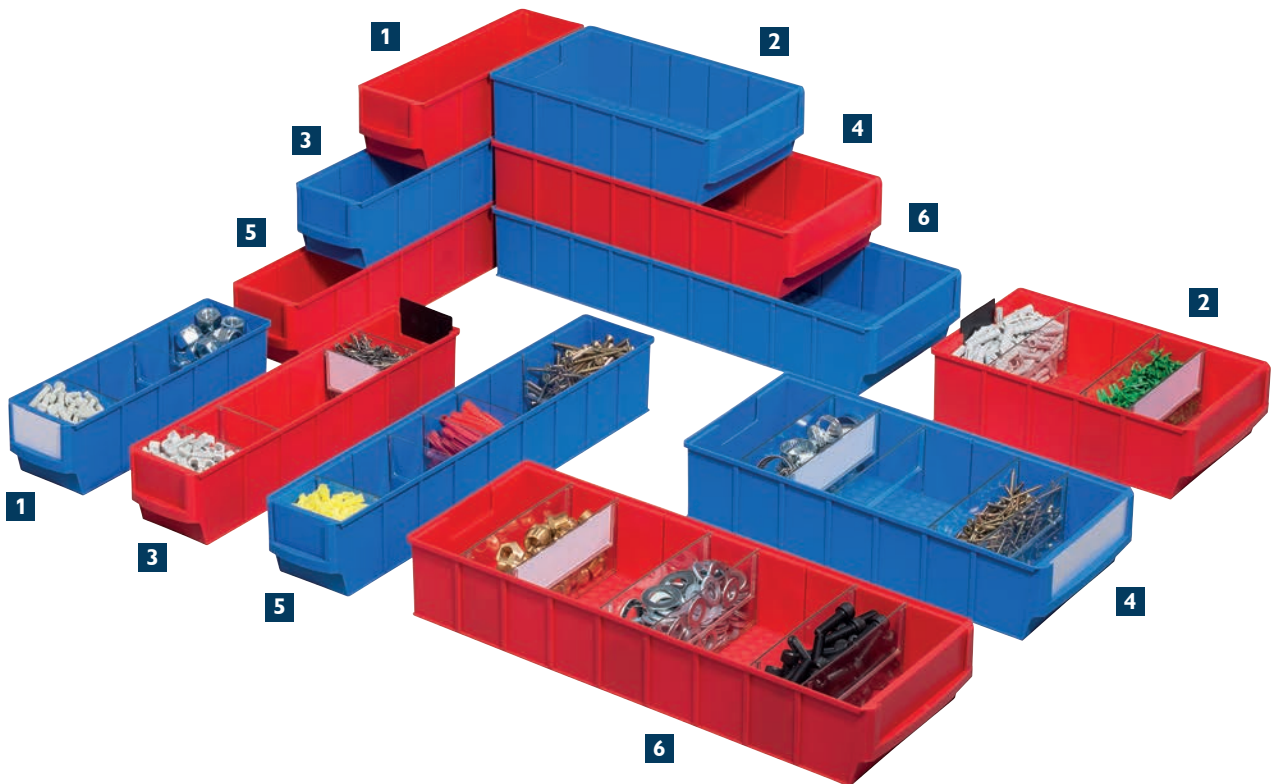

1 ProfiPlus ShelfBox 300S	456520(1)	456521(8)	91 x 300 x 81	80 x 270 x 75	48	768	5	
2 ProfiPlus ShelfBox 300B	456530(0)	456531(7)	185 x 300 x 81	170 x 270 x 75	24	384	5	
3 ProfiPlus ShelfBox 400S	456540(9)	456541(6)	91 x 400 x 81	80 x 370 x 75	48	576	5	
4 ProfiPlus ShelfBox 400B	456550(8)	456551(5)	185 x 400 x 81	170 x 370 x 75	24	288	5	
5 ProfiPlus ShelfBox 500S	456560(7)	456561(4)	91 x 500 x 81	80 x 470 x 75	24	384	5	
6 ProfiPlus ShelfBox 500B	456570(6)	456571(3)	185 x 500 x 81	170 x 470 x 75	12	192	5	

EAN = 4005187 + Art. Nr. ohne führende „4“ + Prüzfiffer (X) / EAN = 4005187 + Art. No. without leading “4” + check digit (X)



Papier, Folie / Paper, film

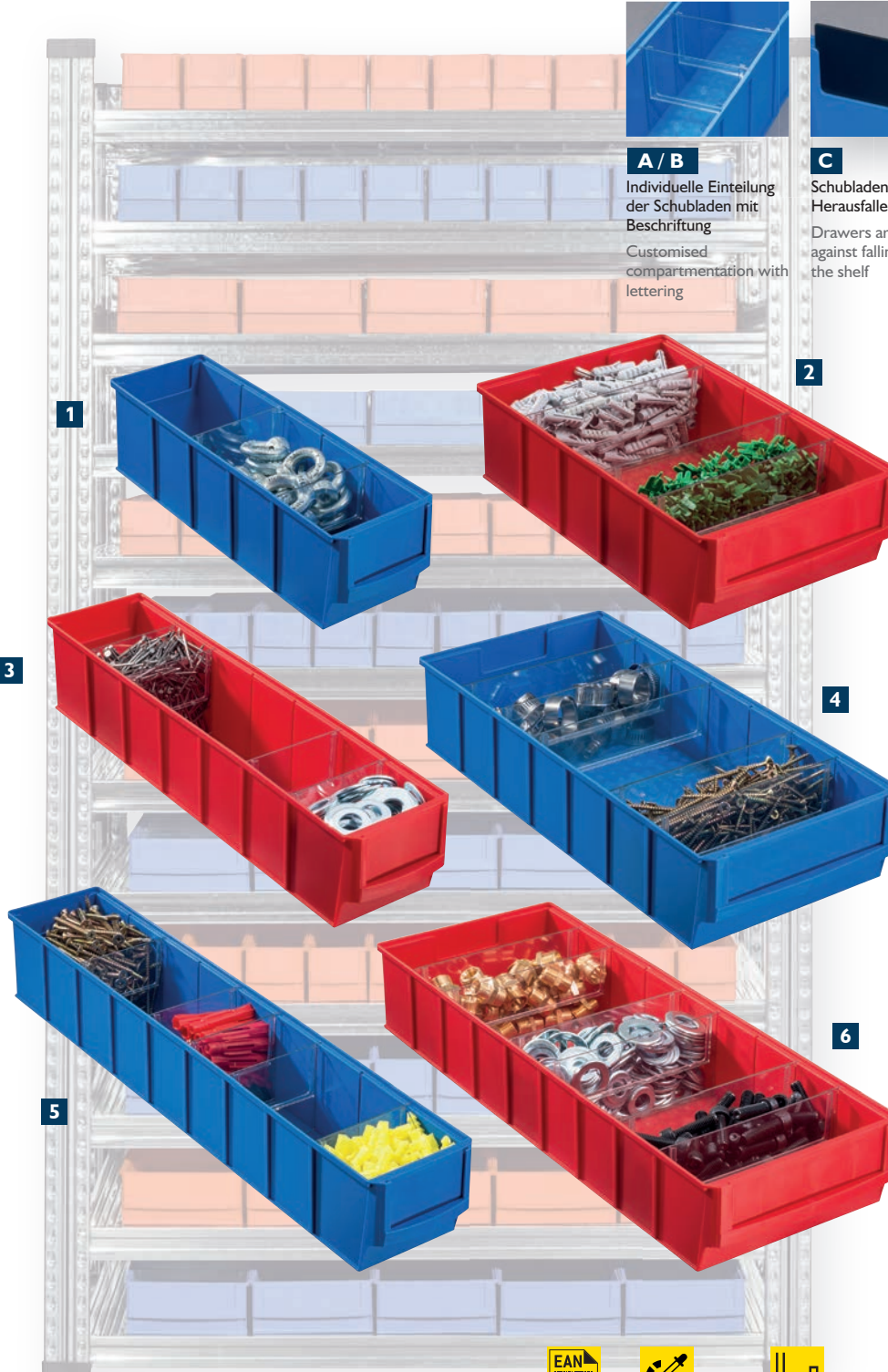



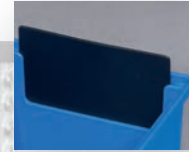







A / B
Individuelle Einteilung der Schubladen mit Beschriftung
Customised compartmentation with lettering



C
Schubladen gegen Herausfallen gesichert
Drawers are secured against falling out of the shelf



D / E
Etiketten + Schutzfolie als Zubehör erhältlich
Label + film available as accessories

			 mm	 1)		
A ProfiPlus ShelfBox Divider S	456590(4)		85 x 1 x 75	1(4)	13.000	5
B ProfiPlus ShelfBox Divider B	456591(1)		175 x 1 x 75	1(4)	6.500	5
C ProfiPlus ShelfBox Stop	456595(9)		70 x 1 x 40	1(10)	15.000	5
D ProfiPlus ShelfBox Label S	456596(6)		70 x 0 x 41	1(20)	6.700	5
E ProfiPlus ShelfBox Label B	456597(3)		150 x 0 x 41	1(20)	3.500	5

EAN = 4005187 + Art. Nr. ohne führende „4“ + Prüfziffer (X) / EAN = 4005187 + Art. No. without leading “4” + check digit (X)

1) Angaben in Klammern = Packungsinhalt (Stück) / 1) information in brackets = quantity per pack (pieces)

ESD-Industrieboxen in 3 Längen & 2 Breiten mit zahlreichem Zubehör

Elektrische Ableitfähigkeit, hohe Belastbarkeit und Beständigkeit zeichnen diese Boxen aus. Industriequalität für hohe Tragkraft. Aus bruchsicherem, hochbelastbarem Polypropylen. Regalangepasst - spart Lagerraum und sorgt für eine hervorragende Übersicht. Beständig gegen gebräuchliche Säuren und Laugen. Formstabil durch extra dicke Wandung.

Closed-front industrial shelf bins available in 3 lengths and 2 widths, complemented with extensive accessories

Static dissipation capability, high load capacity and durability are the key features of these shelf bins. Industrial-grade quality for high load capacity. Made of shatter-proof, high-impact polypropylene. Dimensioned to fit perfectly into the shelf – for streamlined storage space and perfect visibility of stored items. Resistant to most common acids and alkalis. Dimensionally stable thanks to the extra thick wall design.

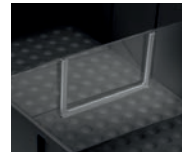

A / B

Individuelle Einteilung der Schubladen mit Beschriftung
Customised compartmentation with lettering

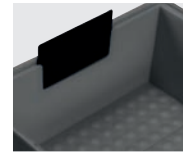

C

Schubladen gegen Herausfallen gesichert
Drawers are secured against falling out of the shelf



Etiketten + Schutzfolie als Zubehör erhältlich (siehe S. 129)

Label + film available as accessories (see p. 129)

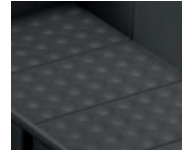

Verbesserte Aufnahme von Kleinteilen dank Noppen am Boxenboden

Knobbed bottom for convenient picking of small parts



Stapelbar
Stackable



Boxen entsprechen den Vorschriften für ESD-Arbeitsplätze

The bins are designed in compliance with the safety regulations for ESD-proof workstations



	EAN	Check digit	Dimensions (mm)	Volume (mm)	Quantity per pack	Weight	Cart icon
1 ProfiPlus ShelfBox >E< 300S	456522(5)	█	91 x 300 x 81	80 x 270 x 75	16	768	5
2 ProfiPlus ShelfBox >E< 300B	456532(4)	█	185 x 300 x 81	170 x 270 x 75	24	384	5
3 ProfiPlus ShelfBox >E< 400S	456542(3)	█	91 x 400 x 81	80 x 370 x 75	16	576	5
4 ProfiPlus ShelfBox >E< 400B	456552(2)	█	185 x 400 x 81	170 x 370 x 75	24	288	5
5 ProfiPlus ShelfBox >E< 500S	456562(1)	█	91 x 500 x 81	80 x 470 x 75	24	384	5
6 ProfiPlus ShelfBox >E< 500B	456572(0)	█	185 x 500 x 81	170 x 470 x 75	12	192	5
A ProfiPlus ShelfBox >E< Div. S	456592(8)	█	85 x 1 x 75	-	1(4)	13.000	5
B ProfiPlus ShelfBox >E< Div. B	456593(5)	█	175 x 1 x 75	-	1(4)	6.500	5
C ProfiPlus ShelfBox >E< Stop	456594(2)	█	70 x 1 x 40	-	1(10)	15.000	5

EAN = 4005187 + Art. Nr. ohne führende „4“ + Prüfziffer (X) / EAN = 4005187 + Art. No. without leading “4” + check digit (X)

1) Angaben in Klammern = Packungsinhalt (Stück) / 1) information in brackets = quantity per pack (pieces)



Metall, Polyamid 6 / Metal, Polyamide 6

Stahlblech-Werkzeughaltesysteme

Mit dem StorePlus Flex M aus Metall schafft sich der Profi-Handwerker oder der anspruchsvolle Heimwerker sein ganz persönliches Ordnungssystem.

Sheet steel tool holder rack systems

StorePlus Flex M is specially designed to assist professional crafters and exacting DIY enthusiasts in creating their own unique and sturdy storage system.



Euro-Norm für alle gängigen Haken und Halter

Euro standard for all common hooks and holders



Hakensortiment
20 Haken in 2 Ausführungen

Hook assortment:
20 hooks in 2 different designs



Hakensortiment
16 Haken in 5 Ausführungen

Hook assortment:
16 hooks in 5 different designs



1



2



3



4



5



6



7



mm



1	StorePlus Flex M 60	455015(3)		400 x 16 x 595	10	5
2	StorePlus Flex M 20	455002(3)		-	6(20)	5
3	StorePlus Flex M 16	455025(2)		-	6(16)	5
4	StorePlus Flex M 8	455135(8)		125 x 25 x 255	4	5
5	StorePlus Flex M 31	455127(3)		270 x 60 x 35	4	5
6	StorePlus Flex M 62	455147(1)		540 x 60 x 35	4	5
7	StorePlus Flex M 58	455055(9)		580 x 150 x 50	4	5

EAN = 4005187 + Art. Nr. ohne führende „4“ + Prüfziffer (X) / EAN = 4005187 + Art. No. without leading “4” + check digit (X)

1) Angaben in Klammern = Packungsinhalt (Stück) / 1) information in brackets = quantity per pack (pieces)

Kunststoff-Werkzeughaltesysteme

Das geniale Ordnungssystem für anspruchsvolle Hobbyhandwerker und preisbewusste Profis. In der Kombination mit den Wandhalteplatten ProfiPlus Endless und den Sichtboxen ProfiPlus entsteht ein endlos und individuell erweiterbares System.

Plastic tool holder systems

The ingenious storage system for the DIY enthusiast and the price-conscious professionals. Combined with ProfiPlus Endless wall panel and ProfiPlus storage bins, StorePlus Flex P makes an infinitely expandable, customised system.

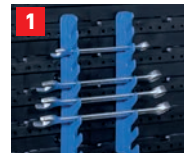

1 Schlüsselhalter für 8 Gabelschlüssel
Passend für StorePlus Flex >P<

Wrench holder for 8 wrenches/spanners
Suitable for StorePlus Flex >P<



2 Werkzeughalter für 24 Werkzeuge
Tool holder for 24 tools

Wrench holder for 24 tools
Tool holder for 24 tools



3 Universalhaken in 2 Längen
Universal hooks Hooks in 2 different lengths

Universal hooks Hooks in 2 different lengths



4 Bohrer-/Bithalter für 39 Bohrer/Bits
Drill/bit holder for 39 drills/bits

Drill/bit holder for 39 drills/bits



Ausreichend Bohrlöcher mit Senkkopf
Sufficient holes with countersunk head

Sufficient holes with countersunk head



Platzierung auch über Stoß möglich
The bins can be placed over joints

The bins can be placed over joints

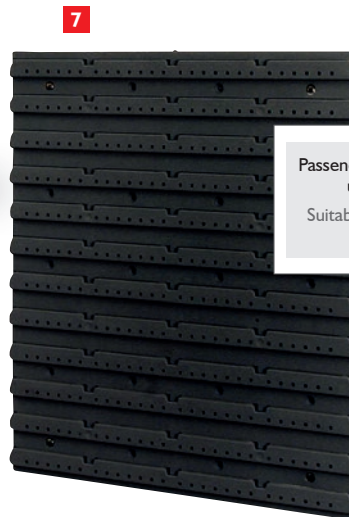
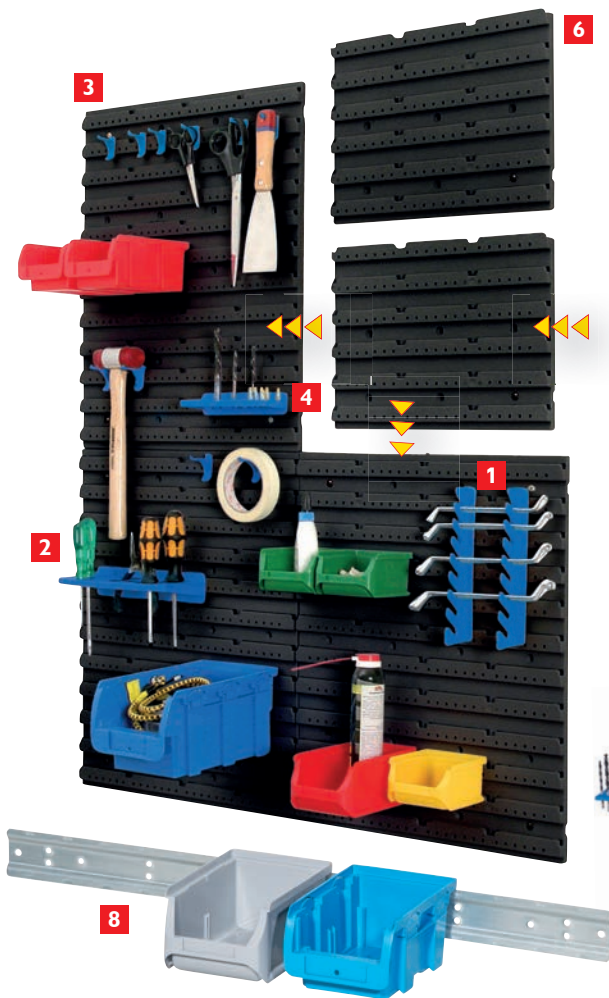

Passend für ProfiPlus Compact (siehe S. 124) und ProfiPlus Box (siehe S. 110)
Suitable for ProfiPlus Compact (see p.124) and ProfiPlus Box (see p. 110)



Im attraktiven Verkaufskarton
In an attractive retail box

1	StorePlus Flex P 8
2	StorePlus Flex P 24
3	StorePlus Flex P 30+40
4	StorePlus Flex P 39
5	StorePlus System >P< 96
6	ProfiPlus Endless 27
7	ProfiPlus Endless 54
8	ProfiPlus Endless 59

EAN	Icon	mm	Icon	Icon
455235(5)		175 x 25 x 210		
455245(4)		230 x 95 x 45		
455012(2)		155 x 51 x 36		
455225(6)		165 x 60 x 32		
457150(9)		610 x 150 x 68		
457080(9)		340 x 20 x 270		
457090(8)		450 x 20 x 540		
457082(3)		590 x 5 x 47		

EAN = 4005187 + Art. Nr. ohne führende „4“ + Prüfziffer (X) / EAN = 4005187 + Art. No. without leading “4” + check digit (X)



Starter-Sets für Ordnung an der Wand

Das geniale Ordnungssystem in den praktischen Starter-Sets für den anspruchsvollen Hobbyhandwerker. Die Sets bestehen aus der Wandhalteplatte ProfiPlus Endless, ProfiPlus Compact und Werkzeughaltern der Serie StorePlus Flex P. Das System ist beliebig und endlos erweiterbar und bietet die optimale Kombination aus Werkzeughaltern und Kleinteileaufbewahrung.

The starter kits for wall storage

The ingenious storage system supplied in the form of starter kits for exacting do-it-yourselfers! The kits are comprised of a ProfiPlus Endless wall panel, ProfiPlus Compact storage bins and StorePlus Flex P tool holders. The system is freely expandable and a versatile solution: tool and small parts storage perfectly combined in one single system.



Werkzeughalter für 24 Werkzeuge
Tool holder for 24 tools

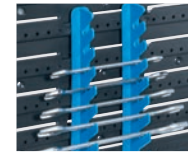

Schlüsselhalter für 8 Gabelschlüssel
Wrench holder for 8 wrenches/spanners

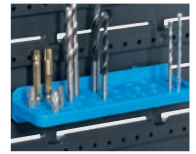

Bohrer-/Bithalter für 39 Bohrer/Bits
Drill/bit holder for 39 drills/bits



Ausreichend Bohrlöcher mit Senkkopf
Sufficient holes with countersunk head



Universalthaken in 2 Längen
Universal hooks in 2 different lengths



Boxen und Werkzeughalter über den Stoß
Bins and tool holders can be placed over joints

1



Werbekarton kann andere StorePlus Sets aufnehmen, da Etikett austauschbar ist.
Promotional box can accommodate other StorePlus sets because label is interchangeable.

Sondervarianten auf Anfrage: /
Special variants on request:

SP001		SP002	
3 x 457090	28 x 455012	4 x 457090	4 x 455245
4 x 456400	2 x 455245	8 x 456400	1 x 455235
4 x 456410	1 x 455235	65 x 455012	1 x 455225
4 x 456420	1 x 455225		



mm



1 StorePlus Set >P< 55

455125(9)

465 x 150 x 570

1

5

EAN = 4005187 + Art. Nr. ohne führende „4“ + Prüfziffer (X) / EAN = 4005187 + Art. No. without leading “4” + check digit (X)

Transport- und Lagerboxen in verschiedenen Materialien (Kunststoff, Aluminium und Metall) bieten für alle Anwendungen das richtige Produkt.

Transport and storage boxes available in a variety of materials (plastic, aluminium or metal) – just the right product for every application.



ProfiPlus EuroBox & EuroEco

136



ProfiPlus EuroRoll ProfiPlus MetallRoll

138

139



F400 Ship

F400 Ship B

F400 Ship HL

F400 Top C & HL & AddOn

140

141

142

143



ProfiPlus CrocoLid

144



ProfiPlus PickPack

146



A300 Ship
A300 Top

151
152



AluPlus Box ›S‹

155



AluPlus Toolbox

156



AluPlus
Basic ›BC‹ 3i1

157



Eurobehälter in Industriequalität

Stapelbare Behälter aus Polypropylen in allen gängigen Euroformaten. Profitieren Sie von der hohen Funktionalität und einfachen Bedienbarkeit unserer Einstiegsmodelle. Sie eignen sich hervorragend für den Transport und die Aufbewahrung hochwertiger Inhalte. Durch die Euromaßlichkeit werden logistische Vorteile optimal genutzt. Widerstandsfähig gegen die meisten Säuren und Öle. Rippenverstärkte, robuste Wände verleihen dem Behälter eine gute Formstabilität.

Euro containers in industrial-grade quality

Stackable polypropylene containers in all commonly used Euro dimensions. Benefit from the outstanding functionality and convenience afforded by our entry-level models. They are perfectly suited for transporting and storing valuable items. Euro dimensions ensure optimised logistics processes. Resistant to most acids and oils. Excellent dimensional stability thanks to rib-reinforced, robust walls.



Der glatte Boden 400 x 300 ermöglicht den Einsatz auf einer Förderanlage

Thanks to their smooth bottom 400 x 300, the containers are suitable for use on conveyor systems



Zubehör Sign Clip verwendbar

Sign Clip can be used as an accessory



Der verstärkte Boden 600 x 400 ermöglicht eine schwere Beladung des Behälters (612 & 617 glatter Boden)

The bottom 600 x 400 is reinforced for heavy loading (612 & 617 smooth bottom)



Auf Anfrage mit Mengenbezug sind die Griffvarianten in Ihrer individuellen Farbe möglich.

Upon request and depending on order volume, the handles can be designed in customised colours.



Kombinierbar mit ProfiPlus EuroRoll (siehe S.138)

Combinable with the ProfiPlus EuroRoll range (see page 138)



Individuelles Corporate Design auf Anfrage

Customised corporate design available upon request

4S Set
4x Schiebescnappverschluss
4x slide snap lock

Lid A
Auflagedeckel
Lid

2+2S Set
2x Schiebescnappverschluss +
2x Scharniere
2x slide snap lock +
2x hinges

Lid S
Scharnierdeckel
Hingetop

Passend für alle EuroBox- und EuroEco-Boxen. Deckel und dazugehörige Schließmechanismen müssen einzeln gekauft werden.

Suitable for all EuroBox- and EuroEco-Boxes. Tops and associated closing mechanisms must be purchased separately.

















































Einheitliche Größen

Alle Behälter gibt es in zwei Grundflächen und vier Höhen.

Uniformly Sizes

All totes are available in two base sizes and four different heights.



			 mm	 mm			
ProfiPlus EuroEco >C< 412	456800(4)		400 x 300 x 120	355 x 255 x 115	1	144	5
ProfiPlus EuroEco >C< 417	456802(8)		400 x 300 x 170	355 x 255 x 165	1	96	5
ProfiPlus EuroEco >C< 422	456804(2)		400 x 300 x 220	355 x 255 x 215	1	72	5
ProfiPlus EuroEco >C< 432	456806(6)		400 x 300 x 320	355 x 255 x 315	1	48	5
ProfiPlus EuroEco >C< 612	456808(0)		600 x 400 x 120	555 x 355 x 115	1	72	5
ProfiPlus EuroEco >C< 617	456810(6)		600 x 400 x 170	555 x 355 x 165	1	48	5
ProfiPlus EuroEco >C< 622	456812(7)		600 x 400 x 220	555 x 355 x 215	1	36	5
ProfiPlus EuroEco >C< 632	456814(1)		600 x 400 x 320	555 x 355 x 315	1	24	5
ProfiPlus EuroEco >O< 412	456801(1)		400 x 300 x 120	355 x 255 x 115	1	144	5
ProfiPlus EuroEco >O< 417	456803(5)		400 x 300 x 170	355 x 255 x 165	1	96	5
ProfiPlus EuroEco >O< 422	456805(9)		400 x 300 x 220	355 x 255 x 215	1	72	5
ProfiPlus EuroEco >O< 432	456807(3)		400 x 300 x 320	355 x 255 x 315	1	48	5
ProfiPlus EuroEco >O< 612	456809(7)		600 x 400 x 120	555 x 355 x 115	1	72	5
ProfiPlus EuroEco >O< 617	456811(0)		600 x 400 x 170	555 x 355 x 165	1	48	5
ProfiPlus EuroEco >O< 622	456813(4)		600 x 400 x 220	555 x 355 x 215	1	36	5
ProfiPlus EuroEco >O< 632	456815(8)		600 x 400 x 320	555 x 355 x 315	1	24	5
ProfiPlus EuroBox 412	456700(7)		400 x 300 x 120	355 x 255 x 115	1	144	5
ProfiPlus EuroBox 417	456705(2)		400 x 300 x 170	355 x 255 x 165	1	96	5
ProfiPlus EuroBox 422	456710(6)		400 x 300 x 220	355 x 255 x 215	1	72	5
ProfiPlus EuroBox 432	456715(1)		400 x 300 x 320	355 x 255 x 315	1	48	5
ProfiPlus EuroBox 612	456740(3)		600 x 400 x 120	555 x 355 x 115	1	72	5
ProfiPlus EuroBox 617	456745(8)		600 x 400 x 170	555 x 355 x 165	1	48	5
ProfiPlus EuroBox 622	456750(2)		600 x 400 x 220	555 x 355 x 215	1	36	5
ProfiPlus EuroBox 632	456755(7)		600 x 400 x 320	555 x 355 x 315	1	24	5
ProfiPlus EuroBox612	456760(1)		600 x 400 x 120	555 x 355 x 115	1	72	5
ProfiPlus EuroBox617	456765(6)		600 x 400 x 170	555 x 355 x 165	1	48	5
ProfiPlus EuroBox622	456770(0)		600 x 400 x 220	555 x 355 x 215	1	36	5
ProfiPlus EuroBox632	456775(5)		600 x 400 x 320	555 x 355 x 315	1	24	5
ProfiPlus EuroBox412	456720(5)		400 x 300 x 120	355 x 255 x 115	1	144	5
ProfiPlus EuroBox417	456725(0)		400 x 300 x 170	355 x 255 x 165	1	96	5
ProfiPlus EuroBox422	456730(4)		400 x 300 x 220	355 x 255 x 215	1	72	5
ProfiPlus EuroBox432	456735(9)		400 x 300 x 320	355 x 255 x 315	1	48	5
ProfiPlus EuroBox Lid A 400	456790(8)		400 x 300 x 10	x x	1	480	5
ProfiPlus EuroBox Lid A 600	456795(3)		600 x 400 x 14	x x	1	240	5
ProfiPlus EuroBox 4S	456781(6)		40 x 10 x 36	x x	1(4)	15.000	5
ProfiPlus EuroBox 4S	456780(9)		40 x 10 x 36	x x	1(4)	15.000	5
ProfiPlus EuroBox Lid S 400	456791(5)		400 x 300 x 14	x x	1	480	5
ProfiPlus EuroBox Lid S 600	456796(0)		600 x 400 x 14	x x	1	240	5
ProfiPlus EuroBox 2+2S	456786(1)		40 x 13 x 30	x x	1(2+2)	15.000	5
ProfiPlus EuroBox 2+2S	456785(4)		40 x 13 x 30	x x	1(2+2)	15.000	5

EAN = 4005187 + Art. Nr. ohne führende „4“ + Prüfziffer (X) / EAN = 4005187 + Art. No. without leading “4” + check digit (X)

¹⁾ Angaben in Klammern = Packungsinhalt (Stück) / ¹⁾ information in brackets = quantity per pack (pieces)

Transportroller für Eurobehälter in Industriequalität

Der Rollwagen ProfiPlus EuroRoll ermöglicht die Beförderung von Kunststoffboxen im Euroformat von A nach B. Der Rahmen des Transportrollers besteht aus stabilem Kunststoff. Aufgrund der kugelgelagerten Lenkrollen, mit Vollgummibereifung, lässt sich der Roller einfach in alle vier Richtungen bewegen. Die hellgrauen, leise laufenden Gummiräder sind mit verzinktem Stahl/rostfreiem Edelstahl an dem Kunststoffrahmen befestigt.

Transport dollies for Euro containers in industrial-grade quality

ProfiPlus EuroRoll dollies are designed for moving Euro format plastic containers from place A to B. The frame of the dolly is made of robust plastic material. Thanks to the ball-bearing mounted swivel castors equipped with solid rubber tyres, the dolly can be swiftly moved in any direction. The dollies silent-running rubber castors, which are designed in light grey, are attached to the plastic frame of the dolly by means of a galvanised steel/stainless steel support.



Passend für ProfiPlus CrocoLid
Suitable for ProfiPlus CrocoLid



Tragkraft von bis zu 250 kg, bei gleichmäßiger Beladung
Load capacity up to 250 kg, when evenly loaded



Optimal passend für Behälter 600 x 400 mm
Perfectly suitable for containers 600 x 400 mm



Lenkrolle (S)
Swivel castor (S)



Bremsrolle (B)
Braked castor (B)



Weitere Farben und Ausführungen auf Anfrage
Further colours and designs upon request

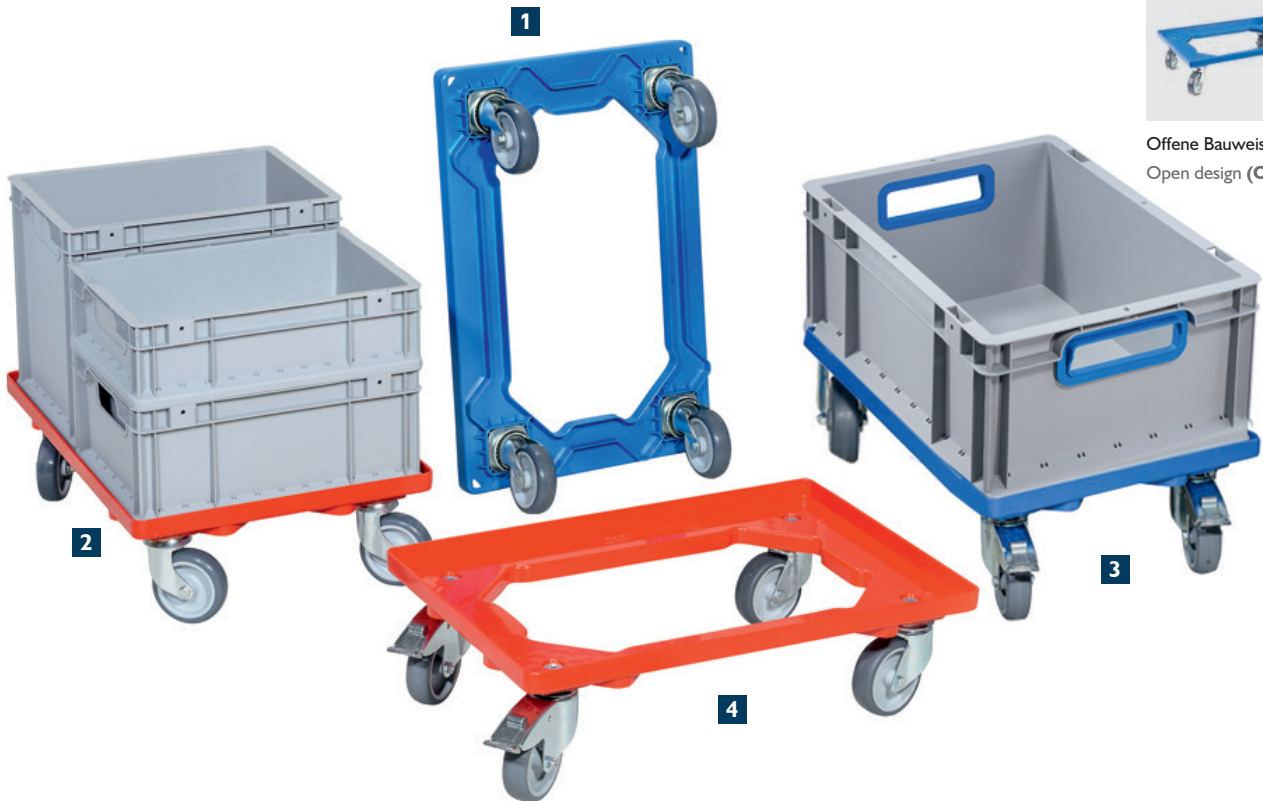

Offene Bauweise (O)
Open design (O)



	EAN	Color	Dimensions (mm)	Container (mm)	Containers	Dollies
1	456856(1)	Blue	615 x 415 x 170	600 x 400 x 25	2	5
2	456866(0)	Red	615 x 415 x 170	600 x 400 x 25	2	5
3	456858(5)	Blue	615 x 415 x 170	600 x 400 x 25	2	5
4	456868(4)	Red	615 x 415 x 170	600 x 400 x 25	2	5

EAN = 4005187 + Art. Nr. ohne führende „4“ + Prüzfiffer (X) / EAN = 4005187 + Art. No. without leading “4” + check digit (X)



ABS-Kunststoff, Aluminium / ABS-plastic, Aluminium

Transportroller für Boxen, Paletten oder andere Gegenstände

Der Rollwagen ProfiPlus MetalRoll ermöglicht die Beförderung unterschiedlichster Gegenstände von A nach B. Robuster kunststoffummantelter Stahlrahmen für den sicheren Transport. Stabile Kunststoffecken mit hohem Rand dienen als Abrutschsicherung. Aufgrund der kugelgelagerten Lenkrollen, mit Vollgummibereifung, lässt sich der Roller einfach in alle vier Richtungen bewegen. Die hellgrauen, leise laufenden Gummiräder sind mit verzinktem Stahl/rostfreiem Edelstahl an dem Kunststoffrahmen befestigt.

Transport dollies for boxes, pallets and many other objects

ProfiPlus MetalRoll dollies are versatile carriers designed for moving objects from place A to B. They feature a plastic-coated sturdy steel frame for safe transport, a low dead weight and a high rim preventing slippage. The dollies silent-running rubber castors, which are designed in light grey, are attached to the plastic frame of the dolly by means of a galvanised steel/stainless steel support.



Offene Bauweise (O)
Open design (O)



Lenkrolle (S)
Swivel castor (S)









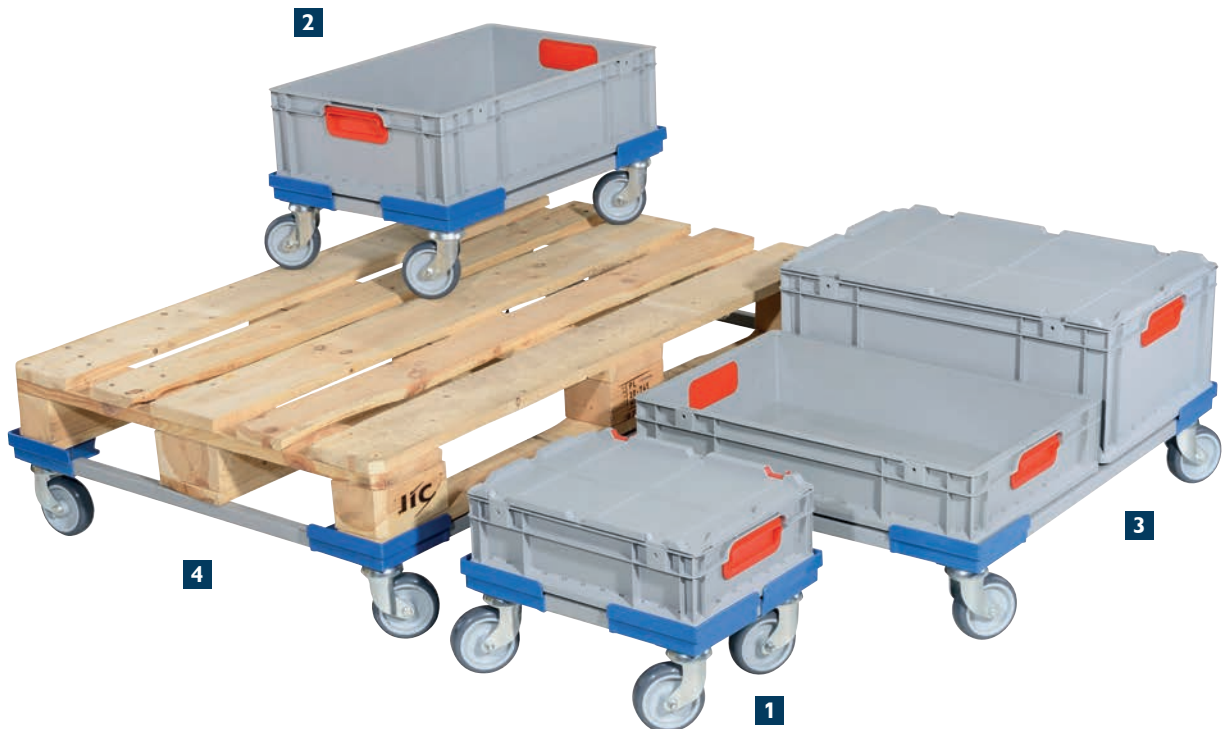



Tragkraft von bis zu 300 kg, bei gleichmäßiger Beladung
Load capacity up to 300 kg, when evenly loaded



Weitere Farben und Ausführungen auf Anfrage
Further colours and designs upon request



			 mm	 mm		
1 ProfiPlus MetalRoll >OS< 400	456870(7)		410 x 310 x 176	400 x 300 x 21	1	5
2 ProfiPlus MetalRoll >OS< 600	456871(4)		610 x 410 x 176	600 x 400 x 21	1	5
3 ProfiPlus MetalRoll >OS< 800	456872(1)		810 x 610 x 176	800 x 600 x 21	1	5
4 ProfiPlus MetalRoll >OS< 1200	456873(8)		1210 x 810 x 176	1200 x 800 x 21	1	5

EAN = 4005187 + Art. Nr. ohne führende „4“ + Prüfziffer (X) / EAN = 4005187 + Art. No. without leading “4” + check digit (X)

F400 Ship Transportbehälter in 600 x 400 mm

- 3 verschiedene Höhen in 4 Standardfarben
- individuelle Farbe auf Anfrage
- für automatisierte Förderanlagen mit manuellem Handling im Logistikzentrum
- für automatische und manuelle Zielsteuerung
- ineinander stapelbar für bis zu 80 % mehr Lagerkapazität
- optimiert für automatische Belegzuführung und -entnahme
- Sicherheit durch Verplombung und Umreifung
- Entwässerungslochungen für Washwasser
- codier- und beschriftbar
- kompatibel zu gängigen Behältern mit diesen Größen
- verstärkter Rippenboden auf Anfrage
- geeignet für den Postversand

F400 Ship Transport Tote in 600 x 400 mm

- 3 different heights in 4 standard colours
- individual colour on request
- for automated conveyor systems with manual handling in the logistics center
- for automatic and manual destination control
- stackable inside each other (nestable) for up to 80 % more storage capacity
- optimised for automatic placement and removal of picking documents
- increased safety and security thanks to sealing and strapping options
- perforations for washing-water runoff
- totes accept coding and individual inscription
- compatible with customary tote bins of the same size
- reinforced ribbed ground on request
- suitable for mailing



*Ineinander nestbar
Nestable inside each other*



*Griffmulden 4-seitig
Recessed grips on four sides*

*Stapelbar
Standfeste Stapel auch bei gemischten Behältergrößen
Stackable
Stable stacking even of mixed tote sizes*



*Thermo auf Anfrage
Thermo upon request*



	1	2	3	4	5	6
1 F400 Ship 173	640171	600 x 400 x 173	495 x 325 x 170	29	140	5
2 F400 Ship 273	640271	600 x 400 x 273	495 x 325 x 270	47	104	5
3 F400 Ship 323	640231	600 x 400 x 323	495 x 325 x 320	58	80	5

Die abgebildeten Behälter stellen unser Standard-Lagerprogramm dar und sind auch mit individuellen Ausstattungen möglich.
The illustrated totes represent our standard stock program and are also available with individual equipment.

keine Barcodeauszeichnung / no barcode labeling

*) Maße ohne Aushebesicherung / dimensions without lifting protection



F400 Ship B Transportbehälter in 600 x 400 mm

- F400 Ship ausgestattet mit Stapelbügel
- lassen in Normalstellung ein Ineinander-Stapeln und Verwendung eines Deckels
- hochgeklappt ermöglichen sie das Übereinander-Stapeln von beladenen Behältern
- auf Grund ihrer robusten Ausführung sind große Stapelhöhen möglich
- besitzt alle Eigenschaften des Transportbehälters

F400 Ship B Transport Tote in 600 x 400 mm

- F400 Ship equipped with stacking rail
- in their default position, the totes are nestable and can be closed with a lid
- when the rails are in folded-up position, loaded totes can be safely stacked
- thanks to the robust rail design, totes can be piled into high stacks
- has all the characteristics of the transport tote



Stapelbügel
Stacking rail

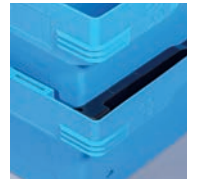

Stapelbar
Stackable



Stapelsicherheit
Secure stacking



- 1**
- = 644172
 - = 644173
 - = 644174

- 2**
- = 644272
 - = 644273
 - = 644274

- 3**
- = 644232
 - = 644233
 - = 644234



	XX	mm*	mm	Box	Pallet	Truck
1 F400 Ship 173 B	644171	600 x 400 x 173	495 x 325 x 170	29	140	5
2 F400 Ship 273 B	644271	600 x 400 x 273	495 x 325 x 270	47	104	5
3 F400 Ship 323 B	644231	600 x 400 x 323	495 x 325 x 320	58	80	5

Die abgebildeten Behälter stellen unser Standard-Lagerprogramm dar und sind auch mit individuellen Ausstattungen möglich.
The illustrated totes represent our standard stock program and are also available with individual equipment.

 keine Barcodeauszeichnung / no barcode labeling

*) Maße ohne Aushebesicherung / dimensions without lifting protection

F400 Ship HL Transportbehälter in 600 x 400 mm

- F400 Ship ausgestattet mit Klappdeckel
- besitzt alle Eigenschaften des Transportbehälters

F400 Ship HL Transport Tote in 600 x 400 mm

- F400 Ship equipped with hinged lid
- has all the characteristics of the transport tote



- = 645172
- = 645173
- = 645174



- = 645272
- = 645273
- = 645274



- = 645232
- = 645233
- = 645234



Ineinander nestbar
Nestable inside each other

Stapelbar
Standfeste Stapel auch bei gemischten Behältergrößen
Stackable
Stable stacking even of mixed tote sizes

Griffmulden 4-seitig
Recessed grips on four sides



Thermo auf Anfrage
Thermo upon request



mm



mm



1 F400 Ship 173 HL

2 F400 Ship 273 HL

3 F400 Ship 323 HL

645171	610 x 410 x 199	495 x 325 x 170	29	100	5
645271	610 x 410 x 299	495 x 325 x 270	47	80	5
645231	610 x 410 x 349	495 x 325 x 320	58	76	5

Die abgebildeten Behälter stellen unser Standard-Lagerprogramm dar und sind auch mit individuellen Ausstattungen möglich.
The illustrated totes represent our standard stock program and are also available with individual equipment.

keine Barcodeauszeichnung / no barcode labeling

*) Maße ohne Aushebesicherung / dimensions without lifting protection



Stül- und Klappdeckel für F400 Ship

- in 4 Standardfarben
- individuelle Farbe auf Anfrage
- ausgelegt für automatisiertes und manuelles Handling
- Aussparungen für Umreifungsbänder
- Stapelung gemischter Behältergrößen möglich
- Codier- und beschriftbar, Verplombbar
- Klappdeckel sind zur Selbstmontage geeignet

Drop-on and hinged lid for F400 Ship

- available in 4 standard colours
- individual colour on request
- optimised for automated and manual handling
- recesses for accommodation of strapping bands / lashing straps
- stacking of different tote bin sizes
- lids accept coding and individual inscription, sealable
- hinged lids are suitable for self-assembly



Vierkantplombe
Lateral pull-off seal



Klappdeckel umreift
Hinged lid secured with strapping bands



Eng anliegende Klappdeckel fächern im gestapten Behälterstapel nicht auf.

The hinged lids sit tightly on the totes so that they will not "fan up" in the nested pile.



Standard-Lieferprogramm Zubehör F400

Stapelbügel, Scharniere, „Safe Seal“ für Verplombung von Stül- und Klappdeckeln

- Plombe zum Eindrücken
- mit Abrissplatte
- mit zwei Widerhaken
- für Plombenloch 10 x 6 mm
- auf Anfrage individuell beschriftbar

Standard product range F400 AddOn

Stacking rails, hinges, „Safe Seal“ for security sealing of drop-on lids and hinged closure lids

- Seal for pressing in place
- With tear-off-plate
- With 2 barbs
- For 10 x 6 mm seal holes
- Customised inscription upon request



Scharniere / Hinge



Plombe / Seal



Stapelbügel / Stacking rail



passend für
suitable for

1	F400 Top C	642001	610 x 410 x 35	400	-	5	-
2	F400 Top HL	646001	610 x 400 x 40	160	-	5	-
3	F400 Hinge	3884349000	68 x 13	-	-	-	F400 Top HL
4	F400 Safe Seal 10 x 6	3917279000	30 x 20 x 17	-	8000	5	F400 Top C & HL
5	F400 Stapelbügel Bail	3880339000	390 x 50 x 30	-	-	5	F400 Ship

Die abgebildeten Behälter stellen unser Standard-Lagerprogramm dar und sind auch mit individuellen Ausstattungen möglich.
The illustrated totes represent our standard stock program and are also available with individual equipment.

keine Barcodeauszeichnung / no barcode labeling

*) Maße ohne Aushebesicherung / dimensions without lifting protection

Nestbare Kunststoff-Transport- und Aufbewahrungsbehälter

Nützliche Helfer zum Verstauen oder Transportieren auch sperriger Gegenstände. Der innovative Klappdeckel ist an der Box anscharniert. Die Behälter ProfiPlus CrocoLid 40 entsprechen dem EURO-Maß von 600 x 400 mm.

Nestable plastic transportation and storage totes

Useful helpers for convenient storage and transport even of bulky items. The innovative flap lid is hinged to the box. The containers ProfiPlus CrocoLid 40 are designed in to the EURO dimension of 600 x 400 mm.



Zweiteiliger Deckel mit sicherer Verzahnung
Two-part finger lid with reliable interlocking mechanism



Ineinander nestbar bei Nichtgebrauch
Nestable while not in use



Bei geschlossenem Deckel stapelbar
Stackable while the lid is closed



mm



mm



1	ProfiPlus CrocoLid 40/27	456656(7)		600 x 400 x 299	495 x 325 x 270	3	5
1	ProfiPlus CrocoLid 40/27	456657(4)		600 x 400 x 299	495 x 325 x 270	3	5
1	ProfiPlus CrocoLid 40/27	456658(1)		600 x 400 x 299	495 x 325 x 270	3	5
1	ProfiPlus CrocoLid 40/27	456659(8)		600 x 400 x 299	495 x 325 x 270	3	5
2	ProfiPlus CrocoLid 40/32	456666(6)		600 x 400 x 349	495 x 325 x 320	2	5
2	ProfiPlus CrocoLid 40/32	456667(3)		600 x 400 x 349	495 x 325 x 320	2	5
2	ProfiPlus CrocoLid 40/32	456668(0)		600 x 400 x 349	495 x 325 x 320	2	5
2	ProfiPlus CrocoLid 40/32	456669(7)		600 x 400 x 349	495 x 325 x 320	2	5

EAN = 4005187 + Art. Nr. ohne führende „4“ + Prüzfiffer (X) / EAN = 4005187 + Art. No. without leading “4” + check digit (X)

i Kombinierbar mit ProfiPlus EuroRoll
 Combinable with ProfiPlus EuroRoll range



i Andere Farbe auf Anfrage
 Further colours upon request



i Geöffnet ineinander stapelbar.
 Nestable with open lid.

Behälter-Transportwagen aus Metall

Der Transportwagen ist das Einsatzwunder zur Steigerung der Prozesseffizienz. Seine Einsatzbereiche können zum Beispiel als Kommissionier-, Kanban-, Transport-/Logistik- oder Werkstattwagen sein. ProfiPlus PickPack dient der übersichtlichen und geordneten Bereitstellung von Arbeitsmitteln, Stückwaren, Werkzeugen, Ersatzteilen, Büroartikeln sowie allen erdenklichen Arbeitsmaterialien und Utensilien. Sie ist so konzipiert, dass sie schnell und einfach durch Bürogänge, über Etagen, Lager- und Regalgänge sowie durch den Kommissionier- und Fertigungsbereich manövriert werden können.

Die robuste Konstruktion widersteht auch anspruchsvollen Einsatzgebieten. Verschwendung in Form von unnötiger Wegen und Bewegung wird vermieden. Vor Ort kann der Transportwagen durch die stabilen Feststellbremsen arretiert werden und somit ebenfalls als Arbeitsfläche dienen. ProfiPlus PickPack verfügt über mehrere in der Höhe verstellbare Etagen.

Tote bin transport trolleys made of metal

The transport trolley is the application miracle for increasing process efficiency. areas of application can be, for example, as order picking, kanban, transport/logistics or workshop trolley. ProfiPlus PickPack is used for clear and orderly provision of work equipment, piece goods, tools, spare parts, office supplies as well as all conceivable work materials and utensils. It is designed in such a way that it can be quickly and easily maneuvered through office aisles, over floors, storage and shelf aisles as well as through the order picking and production area.

The robust construction also withstands demanding areas of application. Waste in the form of unnecessary paths and movement is avoided. The transport trolley can be locked on site by the stable parking brakes and thus also serve as a work surface. ProfiPlus PickPack has several levels that can be adjusted in height.



Verschiedene
Zubehöre verfügbar
(ab S. 149)
Various accessories
available (from p. 149)



Stoßkanten oben und
unten
Abutting edges above
and below



Schneller Zugriff auf
Behälterinhalte
Quick access to
container contents



Individuelle Höhenver-
stellung möglich
Individual height
adjustment possible



Behälter beidseitig
entnehmbar
Can be removed from
both sides



Behälter vor
Herausgleiten gesichert
Container secured
against sliding out

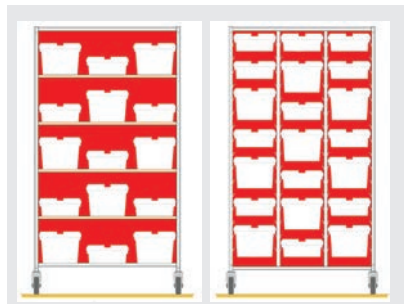

Behälterregal bietet durch flexible Einteilung der
Schiene mehr Platz als ein Wagen mit Regalböden

Thanks to the flexible arrangement of the rails, the
container shelf offers more space than a trolley with
shelves



Stapelbehälter benötigen im leeren Zustand um
einiges weniger an Platz als z. B. Euro-Behälter
When empty, stacking containers take up a lot less
space than e.g. Euro containers



Metall / metal

Mögliche Einsatzbereiche:

- Werkzeuge und Reparaturen
- Maschinenwartung aller notwendigen Parameter
- Werkzeug zusammenstellen und an Maschine fahren
- Autowerkstatt
- Werkzeuge
- Sanitärbetriebe
- Vorkonfektionierung von Servicefahrzeugen
- Interne Postverteilung
- Krankenhaus
- Auslieferung innerhalb des Gebäudes
- Drop-Shipment
- Apotheken

Possible areas of application:

- Tools and repairs
- Machine maintenance and all the necessary parameters
- Toolassembly and transport to the machine
- Service station
- Tools
- Plumbing companies
- Pre-assembly of service vehicles
- Internal Mail distribution
- Hospital
- Deliveries inside the building
- Drop-Shipment
- Pharmacy



Bitte kontaktieren Sie uns bezüglich einer individuellen Bestückung des Wagens!
Please contact us for an individual configuration of the Rack!

Fertig bestückte Komplettsysteme

Die robusten Tourenwagen kommen komplett bestückt mit gängigen Behälterkombinationen für den professionellen Einsatzbereich. Einen Artikel bestellen – die komplette Lösung erhalten.

Fully equipped systems

Robust wall racks, free-standing stationary racks and mobile racks – fully equipped with the most popular bin assortments designed for use in professional environments. Order one item – get the perfectly integrated solution.



Deckel, Platte und weitere Zubehöre verfügbar (ab Seite 150)
Lids, plate and other accessories available (from p. 150)



Enthält / contains:
18x A300 Ship 110



Enthält / contains:
18x A300 Ship 160

Inklusive Abdeckplatte
Inclusive cover plate



1



2



1 ProfiPlus PickPack S 1/18

444100(0)



1120 x 590 x 1210



1

21

2 ProfiPlus PickPack M 1/18

444200(0)



1120 x 590 x 1505



1

21

EAN = 4005187 + Art. Nr. ohne führende „4“ + Prüfziffer (X) / EAN = 4005187 + Art. No. without leading “4” + check digit (X)



Metall / Metal



Behälter und Deckel in mehreren Farben verfügbar (ab Seite 151) / Totes and Lids available in different colors (from p. 151)



Enthält / contains:
18x A300 Ship 210



Enthält / contains:
12x A300 Ship 210
5x A300 Ship 260



1



2



1 ProfiPlus PickPack L 1/18

444300(8)



1120 x 590 x 1805

1

21

2 ProfiPlus PickPack L 2/17

444350(6)



1120 x 590 x 1805

1

21

EAN = 4005187 + Art. Nr. ohne führende „4“ + Prüfziffer (X) / EAN = 4005187 + Art. No. without leading “4” + check digit (X)

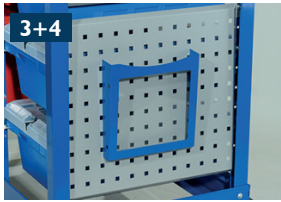

3+4
Dokumentenhalter für DIN A4 Papier
Document holder for DIN A4 pages



2+6+7
Klemmbrett in 2 Größen
Clipboard in 2 sizes



9
Haltestange zum besseren Rangieren
Handrail for better maneuvering

Zubehör für Behälter-Transportwagen

Alle Ausführungen lassen sich durch nützliches Zubehör erweitern.
Alle Artikel werden inklusive Befestigungsmaterial geliefert.

Accessories for tote bin transport trolley

All versions can be expanded with usefull accessories.
All items are supplied including mounting hardware.

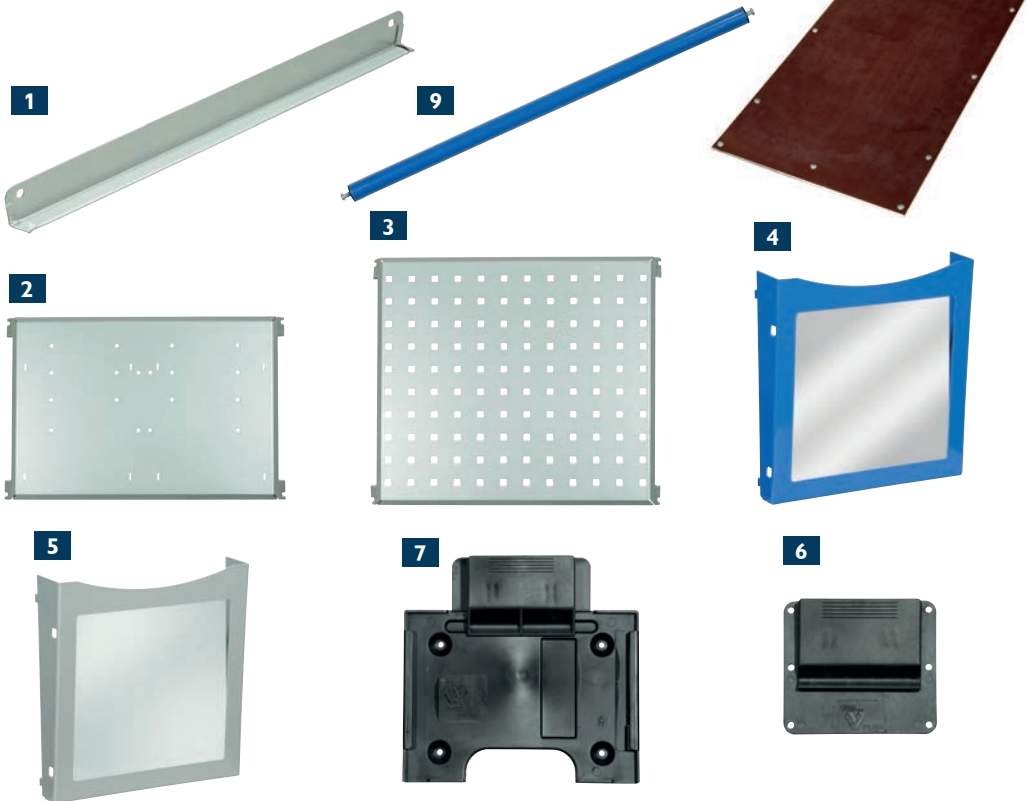

1 ProfiPlus PickPack Rail 53	444700(2)		Leiste für Behälter / Rail for containers	1 21
2 ProfiPlus PickPack Wall 1	444710(1)		Seitenwand / Wall	1 21
3 ProfiPlus PickPack Wall 2	444715(6)		Lochwand / Pegboard	1 21
4 ProfiPlus PickPack Holder 1	444720(0)		Dokumentenhalter DIN A4 / Document holder DIN A4	1 21
5 ProfiPlus PickPack Holder 2	444725(5)		Dokumentenhalter DIN A4 / Document holder DIN A4	1 21
6 ProfiPlus PickPack Board M*	444730(9)		Klemmbrett klein / Clipboard small	1 21
7 ProfiPlus PickPack Board L*	444735(4)		Klemmbrett DIN A4 / Clipboard DIN A4	1 21
8 ProfiPlus PickPack Plate 108	444740(8)		Abdeckplatte / Cover plate	1 21
9 ProfiPlus PickPack Bar 53	444750(7)		Haltestange / Handrail	1 21

EAN = 4005187 + Art. Nr. ohne führende „4“ + Prüfziffer (X) / EAN = 4005187 + Art. No. without leading “4” + check digit (X)

* Nur in Verbindung mit 444710 erhältlich / Only available in conjunction with 444710



A300 Ship Transportbehälter in 300 mm Breite

- 4 verschiedene Höhen in bis zu 4 Standardfarben
- individuelle Farbe auf Anfrage
- für automatisierte Förderanlagen mit manuellem Handling im Logistikzentrum
- für automatische und manuelle Zielsteuerung
- ineinander stapelbar für bis zu 80% mehr Lagerkapazität
- optimiert für automatische Belegzuführung und -entnahme
- Sicherheit durch Verplombung und Umreifung
- optionale Entwässerungslochungen für Waschwasser
- Codier- und beschriftbar
- 5 Schiebescibe stufenlos verstell- und arretierbar

A300 Ship transport tote in 300 mm width

- 4 different heights in up to 4 standard colours
- individual colour on request
- for automated conveyor systems with manual handling in the logistics center
- for automatic and manual destination control
- stackable inside each other (nestable) for up to 80% more storage capacity
- optimised for automatic placement and removal of picking documents
- increased safety and security thanks to sealing and strapping options
- optional perforations for washing-water runoff
- totes accept coding and individual inscription
- 5 Sliding plate continuously adjustable and lockable



Erhältliches Zubehör
(siehe Katalog Behälter)

Accessories
Available accessories (see catalogue Totes)



Schaumstoffeinlage
Auf Anfrage erhältlich

Foam insert
Available upon request



Isolierbehälter
(siehe Katalog Behälter)

Refrigeration
Insulating box
(see catalogue Totes)



		mm	mm			
1 A300 Ship 110	110111	490 x 300 x 110	436 x 258 x 100	13,3	1	5
2 A300 Ship 160	110161	490 x 300 x 160	426 x 249 x 150	19	1	5
3 A300 Ship 210	110211	490 x 300 x 210	417 x 237 x 205	25	1	5
4 A300 Ship 260	110261	490 x 300 x 260	407 x 230 x 250	29,5	1	5
5 A300 Store 210S	111211	490 x 300 x 210	398 x 239 x 207	25	1	5

Die abgebildeten Behälter stellen unser Standard-Lagerprogramm dar und sind auch mit individuellen Ausstattungen möglich.
The illustrated totes represent our standard stock program and are also available with individual equipment.

keine Barcode-Auszeichnung / contains no barcode

A300 Top Stülp- und Verschlussdeckel

- in bis zu 5 Standardfarben
- individuelle Farbe auf Anfrage
- Verschlussdeckel mit einer oder zwei Verschlussfedern
- ausgelegt für automatisiertes und manuelles Handling
- Aussparungen für Umreifungsbänder
- Stapelung gemischter Behältergrößen möglich
- Codier- und beschriftbar
- verplombbar
- optional Briefkastenschlitz oder Beleghalterclips

A300 Top Fold-over lid and closure lid

- available up to 5 standard colours
- individual colour on request
- closure lid including one or two spring locks
- optimised for automated and manual handling
- equipped with recesses for accommodation of strapping bands / lashing straps
- stacking of different tote bin sizes
- lids accept coding and individual inscription
- sealable
- optional letterbox slot or document holder clips

A300 Top DL



A300 Top L mit Einhängenase auf der Unterseite.

A300 Top L with hanging nose on the underside.



Standfeste Stapel auch bei gemischten Behältergrößen

Stable stacking even of mixed tote bin sizes



Stärkt die Marke und verringert den Schwund

Strengthens the brand, reduces loss



	= 113001
	= 113002
	= 113003
	= 113004
	= 113005

	= 112001
	= 112002
	= 112003
	= 112004
	= 112006

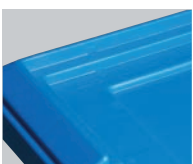

Deckelvariante A mit zusätzlicher Stapelkontur
Lid type A with stacking contour profile



Deckelvariante B mit Stapelcken
Lid type B with stacking corners

Deckelvarianten A300 Top

Beim Aufeinanderstapeln von Behältern geben Spezialdeckel durch besondere Profile dem jeweils oben stehenden Behälter mehr Halt und vermeiden das Umherrutschen des oberen Behälters auf dem Deckel des unten stehenden Behälters. Universelle Deckelvariante bei gemischtem Einsatz von mehreren Behältergrößen.

Lid types A300 Top

When tote bins are stacked, special lids equipped with relief profiles provide support to the respective upper tote bin and thus prevent it from slipping about on the lid of the tote bin below. A universal lid type for use with mixed tote bins sizes.

Oben	Unten
Behälter	Empfohlener Deckel
oben	für unteren Behälter
A300 Ship 110	Deckelvariante A
A300 Ship 160	Deckelvariante B
A300 Ship 210	Deckelvariante A
A300 Ship 260	Deckelvariante A/B

Top	Unten
Upper	Recommended lid for
tote bin	the tote bin below
A300 Ship 110	Deckelvariante A
A300 Ship 160	Deckelvariante B
A300 Ship 210	Deckelvariante A
A300 Ship 260	Deckelvariante A/B

1 A300 Top L	113001	501 x 311 x 42	0,52	1250 x 1160 x 2270	1	5	10
2 A300 Top C	112001	501 x 311 x 42	0,52	1250 x 1160 x 2270	1	5	10

Die abgebildeten Behälter stellen unser Standard-Lagerprogramm dar und sind auch mit individuellen Ausstattungen möglich.
The illustrated totes represent our standard stock program and are also available with individual equipment.

keine Barcode-Auszeichnung / contains no barcode | *transparent



& POM / POM



Safe Lock

Verschlusschieber für Verschlussdeckel, federnd

- Eigenentwicklung
- wartungsfrei, aus einem Stück
- für die gegenüberliegende Seite ist kein weiterer Schieber erforderlich, da der Deckel dort mit einer innenliegenden Einhängenase im Behälterrand eingehängt wird

Closure lid with spring lock

- In-house development
- Maintenance-free, one-piece moulded design
- No additional lock is required for the opposite side of the tote because the lids are equipped with an inside suspension hook engaging with the tote's border



Verschlussplombe (Ringplombe) für Verschlussdeckel A300

Auch ohne Verschlusschieber einsetzbar bei Stülpdeckel B330 und Klappdeckel C330

Security seal (ring pull seal) for closure lid A300

Usable also without spring lock for fold-over lid B330 and hinged lid C330



Safe Seal

Verschlussplomben für Stülp-, Klapp- und Verschlussdeckel

- zum Eindrücken
- mit Abrissring/-platte
- mit 2 Widerhaken
- für Plombenloch 4 x 6 mm und 10 x 10 mm
- auf Anfrage individuell beschriftbar

Seals for fold-over lids, hinged and closure lids

- For pressing in place
- With a tear-off ring/rectangular plate
- With 2 barbs
- For seal holes dimensioned 4 x 6 mm or 10 x 10 mm
- Customised inscription upon request

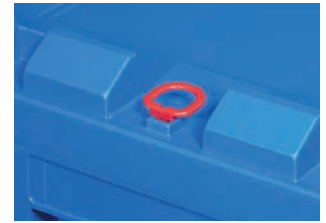

A300 mit Ringplombe A300 with ring pull seal



Verschlussplombe (Vierkantplombe) für Stülpdeckel

Security seal (lateral pull-off seal) for fold-over lid



Safe Padlock Flex

Schloss mit Stahlband
- passend zu A300 Top L
- Mit Zahlenschloss

Lock with steel band
- Suitable for A300 Top L
- With combination lock

			RAL 9004	RAL 3000	RAL 1018	RAL 5019	RAL 6032			
1 Safe Lock	Verschlusschieber spring lock	POM	2141509000	-	-	-	-	5	1200	A300 Top L, C330 Top L
2 Safe Seal 4 x 6	Ringplombe ring pull seal	PE	1623259001	1623253000	1623251000	1623255000	1623256000	5	9000	A300 Top L, B330 Top C, C330 Top L
3 Safe Seal 10 x 10	Vierkantplombe lateral pull-off seal	PP	3955349003	-	-	-	-	5	7500	A300 Top C, C330 Top C
4 F400 Safe Seal 10 x 6	Vierkantplombe lateral pull-off seal	PP	3917279000	-	-	-	-	5	8000	F400 Top C & HL
5 Safe Padlock Flex	Schloss Lock	Metal	6150000458	-	-	-	-	5	1	A300 Top L, F400

Auf Anfrage ab 1.000 Stück auch in Sonderfarben möglich.
Special colours (spot colours) can be implemented for order quantities starting from 1.000 pcs.



keine Barcode-Auszeichnung / contains no barcode

Adresstaschen mit Führung für Transportbehälter

Auch für automatische Behälteradressierung (ABA). In zahlreichen Materialien, Größen und Formen – wir beraten Sie gerne und lassen Ihnen weitere Detailinformationen zukommen.

Address pockets with folded top border for shipping totes

Also suitable for automatic placement of address labels. Available in many materials, sizes and shapes – we will be happy to advise you and provide detailed information.



Klebeadresstasche
Selbstklebende Adresstaschen zur einfachen Anbringung am Behälter, ...

Adhesive address pocket
Self-adhesive address pockets for easy assembly to totes, ...



... extra starke Haftkraft durch zwei Streifen Schaumkleber auf der Rückseite (Sign Address Kit 200/90)

... extra strong adhesion thanks to two rear-side strips of foaming adhesive (Sign Address Kit 200/90)

Adresstaschen in verschiedenen Ausführungen und Größen lieferbar: Address pockets come in many shapes and sizes:

Sonderausführungsbeispiele Examples of special versions

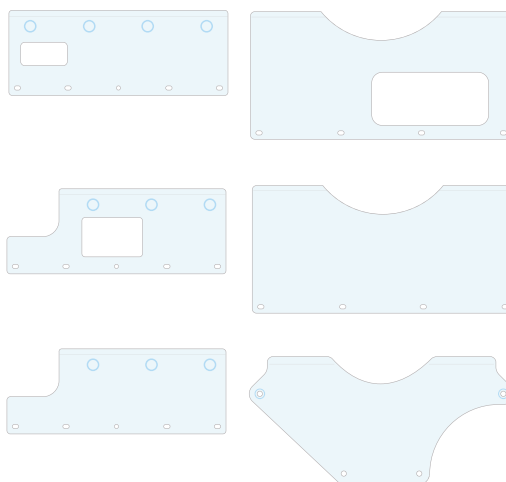

Standard

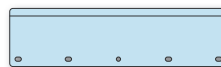

1 Sign Address 200 x 75/90

2 Sign Address 210 x 74

Adresstasche geklebt

Adhesive address pocket

6070000287

6070000297

200 x 90

210 x 74

21

21

* Kit besteht aus der Adresstasche, 5 Nietoberteilen, 5 Nietunterteilen und einem Verstärkungsstreifen.

* Kit consists of: address pocket, 5 rivet front parts, 5 rivet rear parts and 1 reinforcement strip.



keine Barcode-Auszeichnung / contains no barcode



Aluminium / Aluminium

Aluminium-Transportboxen

Stabile Aluminiumboxen in vernünftigem Qualitäts-/Preisverhältnis. Sicherer, geschützter Transport und Aufbewahrung. Leichtes, sehr stabiles Gehäuse mit Federfallgriffen und Hebel-Spannbügelverschlüssen. Aluminium Materialstärke mindestens 0,8 mm: korrosionsfrei, temperatur- und witterungsbeständig.

Aluminium transport boxes

Sturdy aluminium chests with an excellent price/quality ratio. Safe and protected transportation or storage thanks to robust corner guards. Light, very stable body with spring-loaded handles and bracket fasteners. Aluminium material thickness minimum 0.8 mm: corrosion-free, temperature and weather-resistant.



Staub- und spritzwassergeschützt durch umlaufende Gummidichtung

Dust and splash-proof thanks to circumferential rubber seal



Verstärkter Boden für mehr Stabilität und Dichtigkeit

Reinforced base for additional stability and tightness



Nachrüstbar mit Sicherheitsschlössern
Retrofittable with security locks



Verschlüsse mit Bohrungen für Zylinder-, Vorhängeschlösser oder für Plombenverschluss

Closures with boreholes for cylinder locks, padlocks or security seals



			mm	mm		
1 AluPlus Box >S< 29	420002(7)		435 x 335 x 265	385 x 285 x 250	1	5
2 AluPlus Box >S< 47	420003(4)		590 x 390 x 270	545 x 340 x 240	1	5
3 AluPlus Box >S< 70	420004(1)		590 x 390 x 380	545 x 340 x 350	1	5
4 AluPlus Box >S< 90	420005(8)		780 x 380 x 375	730 x 330 x 345	1	5
5 AluPlus Box >S< 140	420006(5)		900 x 490 x 380	850 x 440 x 345	1	5
6 AluPlus AddOn Lock	420012(6)		22 x 22 x 18	-	1(2)	5

EAN = 4005187 + Art. Nr. ohne führende „4“ + Prüfziffer (X) / EAN = 4005187 + Art. No. without leading “4” + check digit (X)

Alu-Rahmen Geräte- und Transportkisten

Die Aluminium-Rahmenboxen eignen sich hervorragend für den sicheren Transport sperriger Maschinen sowie von Büromaterial und Geräten. Der Inhalt wird durch die robuste Kunststoffoberfläche, stabile Ecken und das starke Aluminium-Profil geschützt.

Aluminium-frame equipment cases & transport crates

These aluminium frame boxes are ideally suited for the safe transport of bulky power tools, office supplies and other equipment. The items inside are protected by a robust plastic surface, sturdy corners and strong aluminium profiles.



2+3+4
Seitliche Tragegriffe für Transport zu zweit
Side handles for transport by two persons



2+3+4
Ablagefächer für Utensilien im Deckel
Lid-integrated storage compartments for implements



1
Solide, abschließbare Verschlüsse
Sturdy, lockable closures



2+3+4
Rückhaltegurte am Deckel
Lid with restraining straps

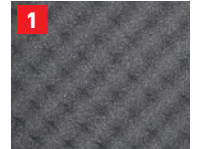

1
Zusätzlicher Schutz durch Schaumstoffpolster im Deckel
Foam lining in the lid for extra protection



	EAN	Color	Dimensions (mm)	Weight (kg)	Volume (L)
1 AluPlus ToolBox 14	421050(7)	Black	365 x 380 x 395	340	5
2 AluPlus ToolBox 18	421100(9)	Black	465 x 375 x 255	425	5
3 AluPlus ToolBox 22	421200(6)	Black	565 x 475 x 355	530	5
4 AluPlus ToolBox 24	421300(3)	Black	615 x 525 x 405	580	5

EAN = 4005187 + Art. Nr. ohne führende „4“ + Prüzfziffer (X) / EAN = 4005187 + Art. No. without leading “4” + check digit (X)



Aluminium, Holz, Kunststoff / Aluminium, wood, plastic



Alu-Rahmen-Gerätekisten

Die Boxen sind hervorragend geeignet für den sicheren Transport sperriger Maschinen und Geräte. Holz-Hartfaserplatten für eine robuste Oberfläche und das stabile Aluminium-Profil sorgen zusammen mit den seitlichen Federfallgriffen für einen bequemen Transport, auch bei schwerer Beladung.

Aluminium-frame equipment cases

These boxes are ideally suited for the safe transport of bulky power tools and other equipment. Hard fibreboards provide these chests with a robust surface, while the sturdy aluminium profile and the spring-loaded handles ensure convenient transport even when the cases are heavily loaded.



Abschließbare Verschlüsse
Lockable closures



Zeitlose Optik, sorgfältige Verarbeitung
Timeless visual appeal, impeccable workmanship



Klappbarer Tragegriff
Foldable carrying handle



Perfekte Zweitplatzierung
Perfect secondary placement



1



485 x 290 x 215 mm



715 x 345 x 320 mm



765 x 400 x 370 mm



mm



mm



1 AluPlus Basic >BC< 3i1

424600(1)

765 x 400 x 370

-

1

5

EAN = 4005187 + Art. Nr. ohne führende „4“ + Prüfziffer (X) / EAN = 4005187 + Art. No. without leading “4” + check digit (X)

StorePlus SteelBox

i Auf Anfrage erhältlich.
Available upon request.



AluPlus ProfiBox »S«



Auf Anfrage erhältlich.
Available upon request.

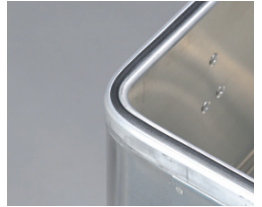

Die schnelle Artikelsuche

Anhand der Artikelnummer können Sie hier die Seitenzahl ermitteln, wo Sie den gesuchten Artikel im Katalog finden.

The fast article search

Using the article number, you can determine the page number where you can find the article you are looking for in the catalogue.

110111	151	454250	62	456657	144	464840	102	454118	77	455946	121
110161	151	454260	62	456658	144	466250	105	454120	76	455947	121
110211	151	454265	62	456659	144	466260	105	454121	76	455950	122
110212	151	454270	62	456666	144	476233	45	454122	76	455951	122
110213	151	454300	64	456667	144	476243	45	454123	76	455970	116
110214	151	454310	64	456668	144	476253	45	454124	76	455971	116
110261	151	454322	64	456669	144	476410	40	454125	77	455972	116
110262	151	454360	68	457206	91	476450	40	454127	77	455973	116
110263	151	454365	68	457405	81	416400	48	454128	77	455974	116
110264	151	454380	66	457406	81	416401	48	454129	77	455975	116
111211	151	454385	67	457407	81	416411	48	455002	131	455976	116
112001	152	454400	73	457415	85	416413	48	455012	132	455977	116
112002	152	454410	73	457425	85	420002	155	455015	131	455978	116
112003	152	454420	73	457426	85	420003	155	455025	131	455979	116
112004	152	454430	73	457600	20	420004	155	455055	131	456180	111
112006	152	454440	73	457605	18	420005	155	455127	131	456181	111
113001	152	454490	70	457610	20	420006	155	455135	131	456200	110
113002	152	454491	70	457615	18	420012	155	455147	131	456201	110
113003	152	454495	73	457620	20	420910	38	455225	132	456202	110
113004	152	455125	133	457625	18	420930	38	455235	132	456203	110
113005	152	455808	75	457630	20	421050	156	455245	132	456204	110
426200	35	455913	117	457635	18	421100	156	455533	106	456205	110
444100	148	455914	119	457640	20	421200	156	455534	106	456206	110
444200	148	455960	118	457645	18	421300	156	455535	106	456207	110
444300	149	455965	118	457700	16	422220	24	455536	106	456208	110
444350	149	455982	119	457710	16	422225	24	455537	106	456209	110
444700	150	456245	110	457720	16	422230	24	455538	106	456210	110
444710	150	456263	110	457730	16	424100	37	455540	111	456211	110
444715	150	456264	110	457800	14	424110	37	455541	111	456212	110
444720	150	456280	110	457810	14	424120	37	455542	111	456213	110
444725	150	456281	110	457820	14	424130	37	455543	111	456214	110
444730	150	456282	110	457830	14	424140	37	455544	111	456215	110
444735	150	456283	110	457970	22	424150	37	455610	106	456216	110
444740	150	456284	110	457980	22	424200	37	455611	106	456217	110
444750	150	456285	110	458685	39	424202	37	455612	106	456218	110
454130	77	456290	110	458800	32	424203	37	455613	106	456219	110
454131	77	456291	110	458801	32	424600	157	455614	106	456221	110
454200	62	456292	110	458810	32	426000	157	455615	106	456222	110
454210	62	456293	110	458811	32	425100	36	455616	106	456223	110
454220	62	456294	110	458830	32	425150	36	455705	111	456224	110
454222	62	456295	110	458850	33	425151	36	455706	111	456225	110
454223	62	456340	79	458860	33	425200	36	455707	111	456230	110
454230	62	456341	79	458865	33	425201	36	455708	111	456231	110
454240	62	456656	144	458890	32	425300	36	455800	90	456232	110
				458891	32	425805	34	455805	74	456233	110
				464411	95	425810	34	455900	114	456234	110
				464421	95	425820	34	455920	115	456235	110
				464431	95	425830	34	455925	115	456240	110
				464441	95	426100	35	455935	114	456241	110
				464451	95	426320	35	455940	121	456242	110
				464675	99	427210	26	455941	121	456243	110
				464800	101	427220	26	455942	122	456244	110
				464810	101	427250	26	455943	122	456260	110
				464830	101	427350	25	455945	121	456261	110
						427355	25				

456262	110	456453	124	456786	137	457170	87	464430	95	640231	140
456300	78	456454	124	456790	137	457175	87	464440	95	640232	140
456301	78	456455	124	456791	137	457180	87	464450	95	640233	140
456302	78	456462	125	456795	137	457190	87	464500	95	640234	140
456303	78	456463	125	456796	137	457195	87	464550	95	640271	140
456304	78	456464	125	456800	137	457200	82	464560	95	640272	140
456305	78	456482	125	456801	137	457201	82	464570	95	640273	140
456306	78	456483	125	456802	137	457202	82	464580	95	640274	140
456307	78	456484	125	456803	137	457203	82	464600	96	642001	143
456308	78	456520	128	456804	137	457204	82	464610	96	642002	143
456309	78	456521	128	456805	137	457210	88	464620	96	642003	143
456310	78	456522	130	456806	137	457220	88	464630	96	642004	143
456311	78	456530	128	456807	137	457225	88	464640	96	644171	141
456312	78	456531	128	456808	137	457230	89	464650	96	644172	141
456313	78	456532	130	456809	137	457234	89	464660	96	644173	141
456314	78	456540	128	456810	137	457235	91	464665	98	644174	141
456315	78	456541	128	456811	137	457240	89	464670	99	644231	141
456316	78	456542	130	456812	137	457250	89	464700	100	644232	141
456317	78	456550	128	456813	137	457278	50	464701	100	644233	141
456318	78	456551	128	456814	137	457279	50	464702	100	644234	141
456319	78	456552	130	456815	137	457280	50	464703	100	644271	141
456400	124	456560	128	456856	138	457285	49	464704	100	644272	141
456401	124	456561	128	456858	138	457360	90	464705	100	644273	141
456402	124	456562	130	456866	138	457370	80	464706	100	644274	141
456403	124	456570	128	456868	138	457410	84	464720	100	645171	142
456404	124	456571	128	456870	139	457420	84	464721	100	645172	142
456405	124	456572	130	456871	139	457430	84	464722	100	645173	142
456410	124	456590	129	456872	139	457900	22	464723	100	645174	142
456411	124	456591	129	456873	139	457910	22	464724	100	645231	142
456412	124	456592	130	457011	42	457915	22	464725	100	645232	142
456413	124	456593	130	457017	43	457920	22	465520	103	645233	142
456414	124	456594	130	457018	43	457930	22	465530	103	645234	142
456415	124	456595	129	457021	42	457935	22	465610	103	645271	142
456420	124	456596	129	457022	43	457936	22	465620	103	645272	142
456421	124	456597	129	457031	41	457940	22	476120	46	645273	142
456422	124	456700	137	457033	41	457950	22	476138	47	645274	142
456423	124	456705	137	457046	126	457960	22	476160	46	646001	143
456424	124	456710	137	457048	126	457990	22	476180	46	646002	143
456425	124	456715	137	457052	112	457991	22	476190	46	646003	143
456430	124	456720	137	457060	112	457992	22	476221	44	646004	143
456431	124	456725	137	457062	112	457993	22	476260	44	1623251000	153
456432	124	456730	137	457072	112	457994	22	476280	44	1623253000	153
456433	124	456735	137	457080	111	458080	104	476320	44	1623255000	153
456434	124	456740	137	457080	132	458090	104	479120	52	1623256000	153
456435	124	456745	137	457082	111	458100	104	479130	52	1623259001	153
456440	124	456750	137	457082	132	458120	104	490610	39	2141509000	153
456441	124	456755	137	457090	111	458140	104	490611	51	3880339000	143
456442	124	456760	137	457090	132	458160	104	490612	51	3884349000	143
456443	124	456765	137	457120	126	458600	39	490613	51	3917279000	143
456444	124	456770	137	457135	112	458601	39	490634	39	3917279000	153
456445	124	456775	137	457150	132	458680	39	640171	140	3955349003	153
456450	124	456780	137	457160	87	464400	95	640172	140	6070000287	154
456451	124	456781	137	457166	87	464410	95	640173	140	6070000297	154
456452	124	456785	137	457168	87	464420	95	640174	140	6150000458	153

Weitergehende Informationen zu den Artikeln finden Sie in unserem Produktfinder www.allit24.com.
For further information about Allit items, please refer to our Product Finder on www.allit24.com.

Technische Änderungen, Sortimentsänderungen, farbliche oder maßliche Abweichungen sowie die Veränderung von logistischen Daten bleiben vorbehalten. Alle Artikel sind nur ohne Dekoration, Werkzeuge und Utensilien erhältlich.

All technical specifications and changes to Allit's product range as well as all details relating to colours, dimensions or logistic information are subject to change and variation without notice. All articles are supplied without decoration, tools or utensils.

Farben / Colours

	anthrazit	anthracite		orange	orange
	blau	blue = ca. RAL 5015		pink	pink
	gelb	yellow = ca. RAL 1021		rot	red = ca. RAL 3020
	grün	green = ca. RAL 6032		schwarz	black
	mint	mint		silber	silver
	grau	grey = ca. RAL 7042		transparent	transparent
				weiß	white

Information / Information

	Information / Information		Farbe / Colour		Artikelnummer (EAN) / Article Number (EAN)
	Stück pro Verpackungseinheit / Pieces per packaging unit		Hochschlagfest / Highly impact-resistant		Telefon / Telephone
	Formbeständig von bis / Dimensionally stable from/to		E-Mail / Email		Fax / Fax
	Beständig gegen Fette, Öle etc. / Resistant to grease, oil etc.		Polypropylen / Polypropylene		Website / Website
	Polystyrol / Polystyrene		Adresse / Address		Recyclingfähig / Recyclable material
	Lieferzeit / Delivery time		Außenmaße in mm (BxTxH) / Outside dimensions in mm (WxDxH)		Palettenmenge / Quantity per pallet
	Nutzmaße in mm (BxTxH) / Usable dimensions in mm (WxDxH)		Flugtauglich / airworthy		Trag-/Auflast / Load capacity per bin/stack load
	keine Barcodeauszeichnung / no barcode labeling		Pulverbeschichtete Oberfläche / Powder-coated surface		Hängelast / Hanging load
	Volumen / volume				





A series of horizontal grey lines for writing notes.

2022 - 2024

Deutsch / English

Allit AG Kunststofftechnik

 Rotlay-Mühle
D-55545 Bad Kreuznach
Germany

 Postfach 1152
D-55501 Bad Kreuznach
Germany

 + 49 (0) 671 291-04

 + 49 (0) 671 291- 125

 diy@allit.de
pro@allit.de

 www.allit.de



Kontakt / Contact

